

Lawrence

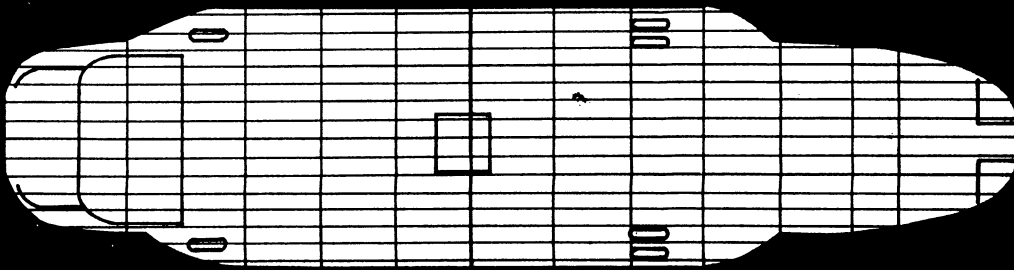
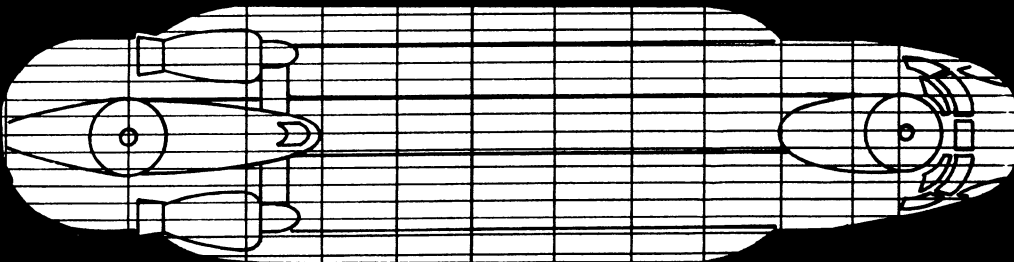
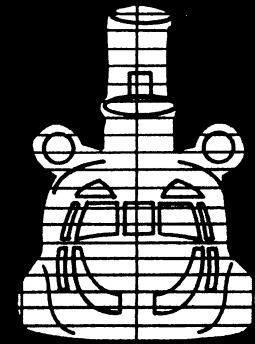
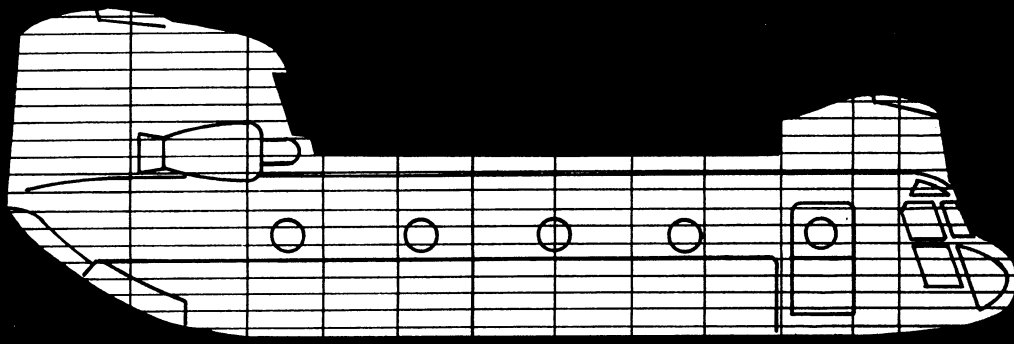
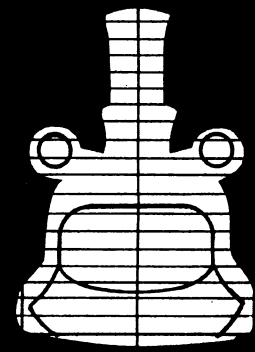
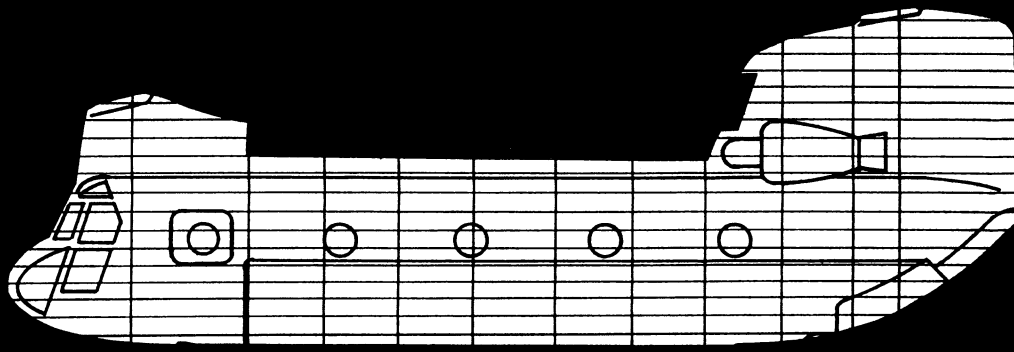

**CH-47D
STRUCTURAL
REPAIR
DOCUMENT**

**CH-47D
STRUCTURAL REPAIR
DOCUMENT
REVISION A**

**Prepared
by**

**Boeing Defense & Space Group
Helicopters Division
P.O. Box 16858
Philadelphia, PA 19142-0858 USA**

for

**Department of the Army
CH-47 Modernization Program
Project Manager
SFAE-AV-CH-L
4300 Goodfellow Blvd.
St. Louis, MO 63120-1798**

INTRODUCTION

THE CH-47D STRUCTURAL REPAIR DOCUMENT HAS BEEN PREPARED TO PROVIDE FIELD PERSONNEL WITH A METHOD TO QUICKLY AND ACCURATELY IDENTIFY STRUCTURAL DAMAGE WHICH WILL REQUIRE PARTS AND PROCEDURES NOT PROVISIONED IN RPSTL TM 55-1520-240-23P OR DESCRIBED IN AVUM/AVIM MAINTENANCE MANUAL TM 55-1520-240-23.

THIS DOCUMENT MUST NOT BE USED TO REPLACE THE REPAIR PROCEDURES IN TM 55-1520-240-23. IT SHOULD BE USED ONLY TO PICTORIALY DESCRIBE STRUCTURAL ASSEMBLIES/SUBASSEMBLIES THAT REQUIRE FACTORY MANUFACTURE AND ASSEMBLY. THE PARTS, FASTENERS, AND INSTRUCTIONS WILL BE PROVIDED TO CH-47D UNITS AS A COMPLETE KIT.

CH-47D STRUCTURAL REPAIR DOCUMENT

PROCEDURE:

- 1. This document is provided to Boeing Field Service Representatives and to Army CH-47D Unit Maintenance Officers by the CH-47 Mod PMO (SFAE-AV-CH-L).**
- 2. When an aircraft has sustained structural damage that requires structural assemblies/subassemblies not normally provisioned as spares, prepare two of these documents. Supplement the documents with photographs and word descriptions of the damage, including complete pictures of the damaged and undamaged surrounding areas.**
- 3. Select an illustration in this document that best presents the damaged area and "color" or "mark" the structural areas that require repair or replacement. Different colors for repair and replacement will aid in the interpretation of the diagrams.**
- 4. Include the aircraft tail number, location, and the organization designation of the unit performing the repair on each marked illustration in this document.**
- 5. When the damage has been assessed and a determination has been made that the repair is within the capability of intermediate maintenance (AVIM), a kit part number will be furnished by the Boeing Field Service Representative or CH-47 Mod PMO (SFAE-AV-CH-L). AVIM will then place the kit part number on requisition through the Army system. All further correspondence should reference this kit part number.**

- 6. Airmail one copy of the completed repair document and data (photographs, word descriptions) to:**

**Department of the Army
CH-47 Modernization Program
Project Manager
Attn: SFAE-AV-CH-L
4300 Goodfellow Blvd.
St. Louis, MO 63120-1798**

Airmail the second copy with all photographs and data to:

**Boeing Defense & Space Group
Helicopters Division
Attn:
P.O. Box 16858
Philadelphia, PA 19142-0858 USA**

- 7. Identify every illustration, photograph, and word description with the aircraft tail number and kit part number when assigned.**
- 8. Boeing will prepare and ship a complete kit of parts, materials, and fasteners for each kit part number.**

LIST OF ILLUSTRATIONS

Figure 1	Stations & Waterlines	Figure 17	Centerline, R.H.*
Figure 2	Aircraft Breakdown	Figure 18	Former Stations 51.75, 70.62 & 95.0
Figure 3	Fairing Structure, L.H.	Figure 19	Former Station 120
Figure 4	Fairing Structure, R.H.*	Figure 20	Former Station 160 & 440
Figure 5	Production Breakdown, R.H.*	Figure 21	Former Station 200
Figure 6	Section 41	Figure 22	Crown Former Stations 180, 220, 260, 300, 340, 380, 420
Figure 7	Forward Pylon	Figure 23	Forward Station 240
Figure 8	Section 43, L.H.	Figure 24	Former Station 280, 320
Figure 9	Section 43, R.H.*	Figure 25	Former Station 360 – 400
Figure 10	Section 46, L.H.	Figure 26	Former Station 482
Figure 11	Section 46, R.H.*	Figure 27	Former Station 502.43
Figure 12	Aft Pylon, L.H.	Figure 28	Former Station 520
Figure 13	Aft Pylon, R.H.*	Figure 29	Former Station 534
Figure 14	Basic Structure, L.H.	Figure 30	Former Station 555
Figure 15	Basic Structure, R.H.*	Figure 31	Former Station 575
Figure 16	Centerline, L.H.	Figure 32	Former Station 594

*** ALL RIGHT HAND views have been developed from mirror views of LEFT HAND drawings. Structure that is not symmetrical may appear in the wrong position from centerline of aircraft.**

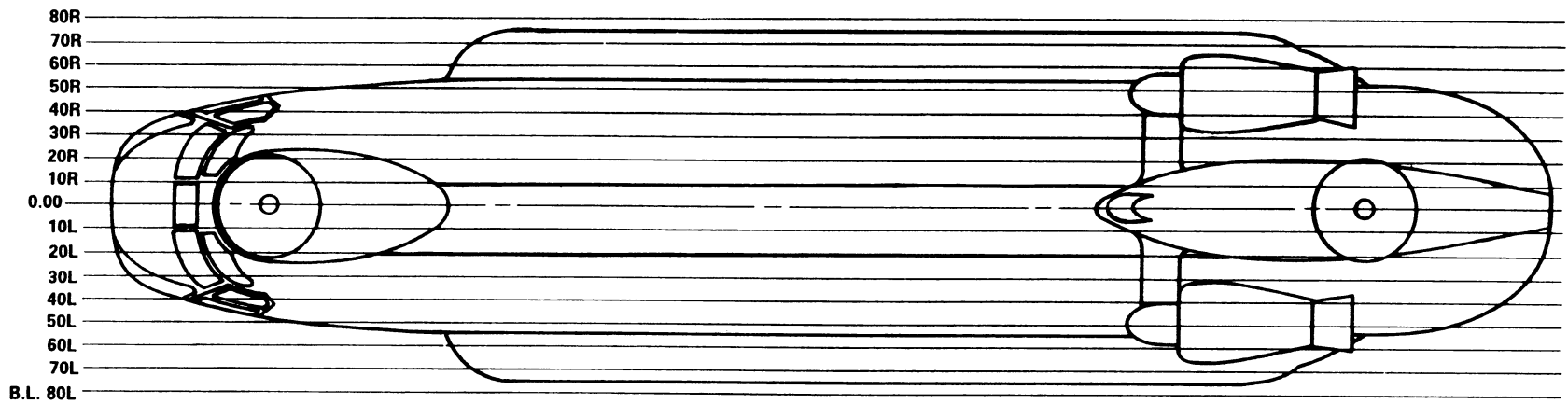

BUTT LINES

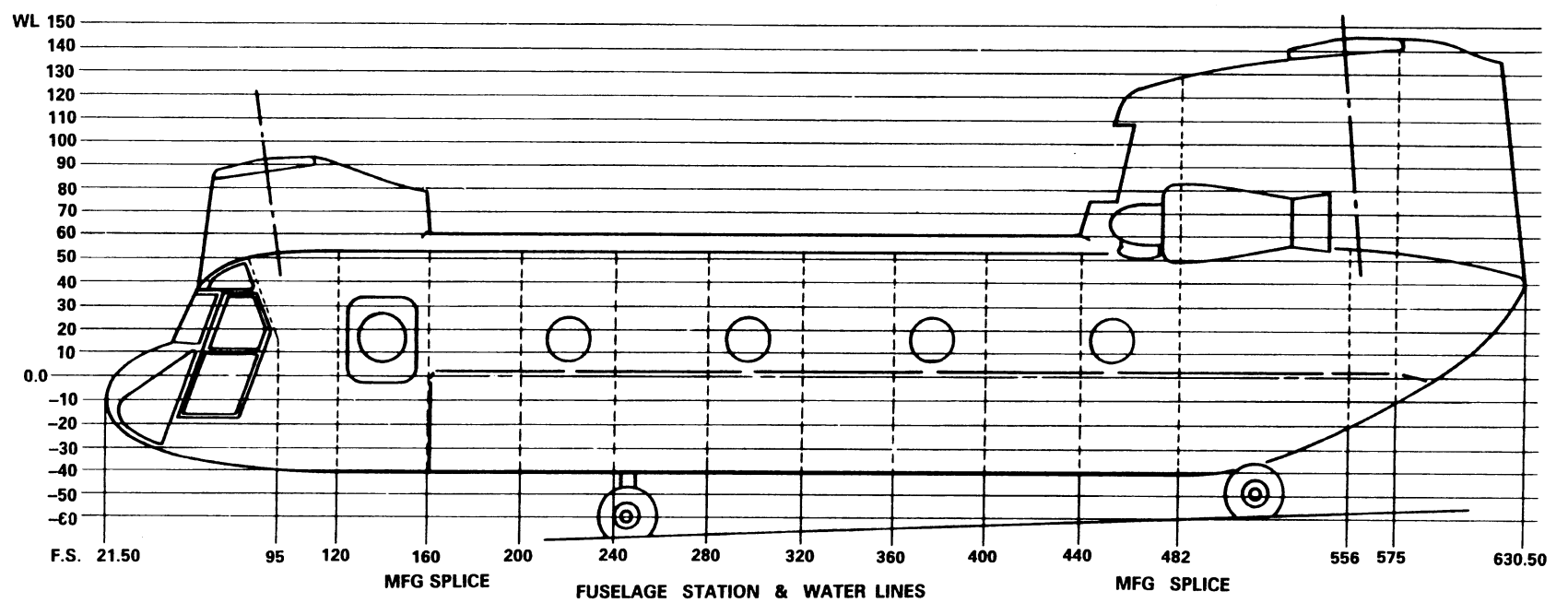

FIGURE 1. STATION & WATERLINES

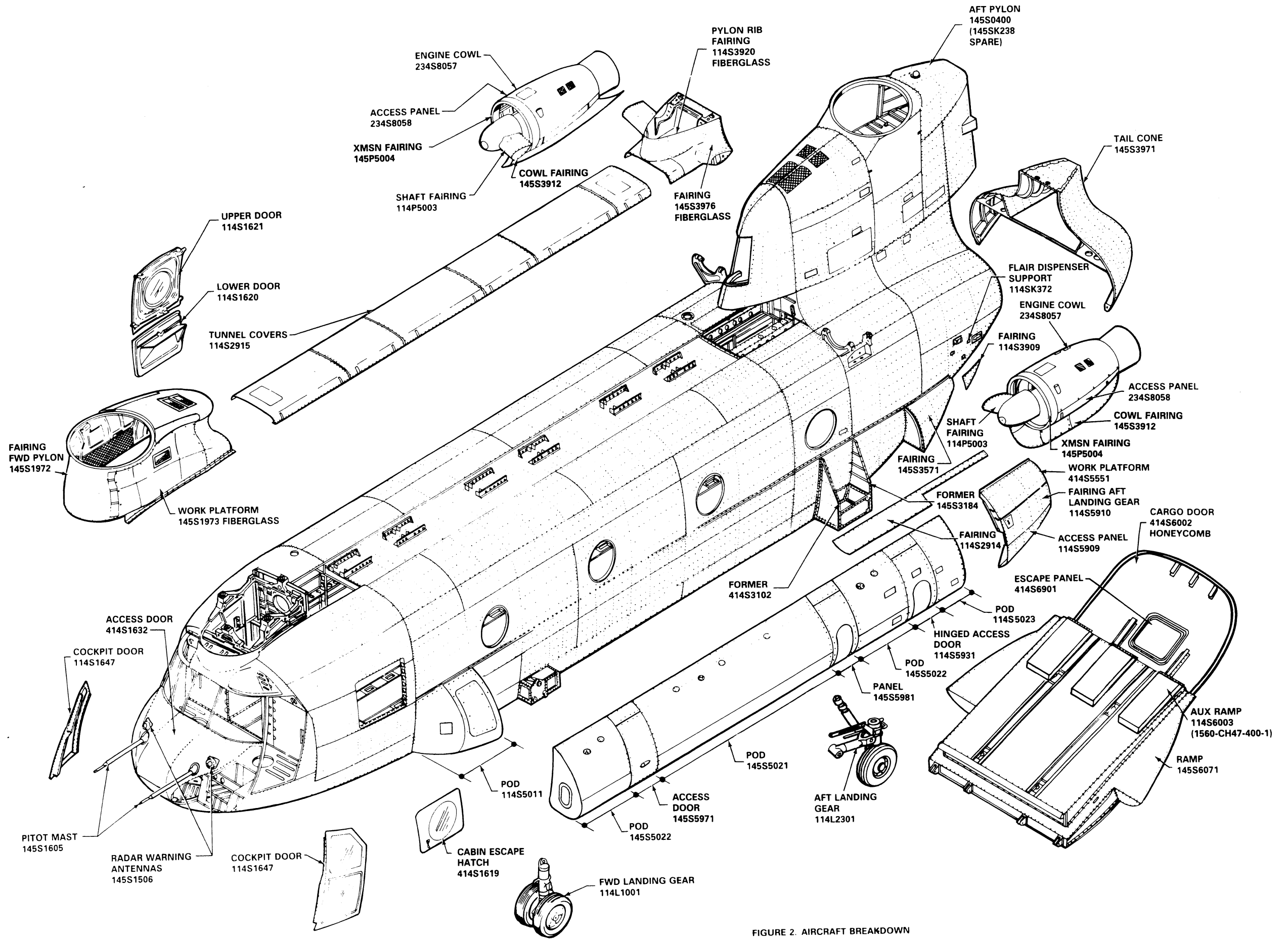

FIGURE 2. AIRCRAFT BREAKDOWN

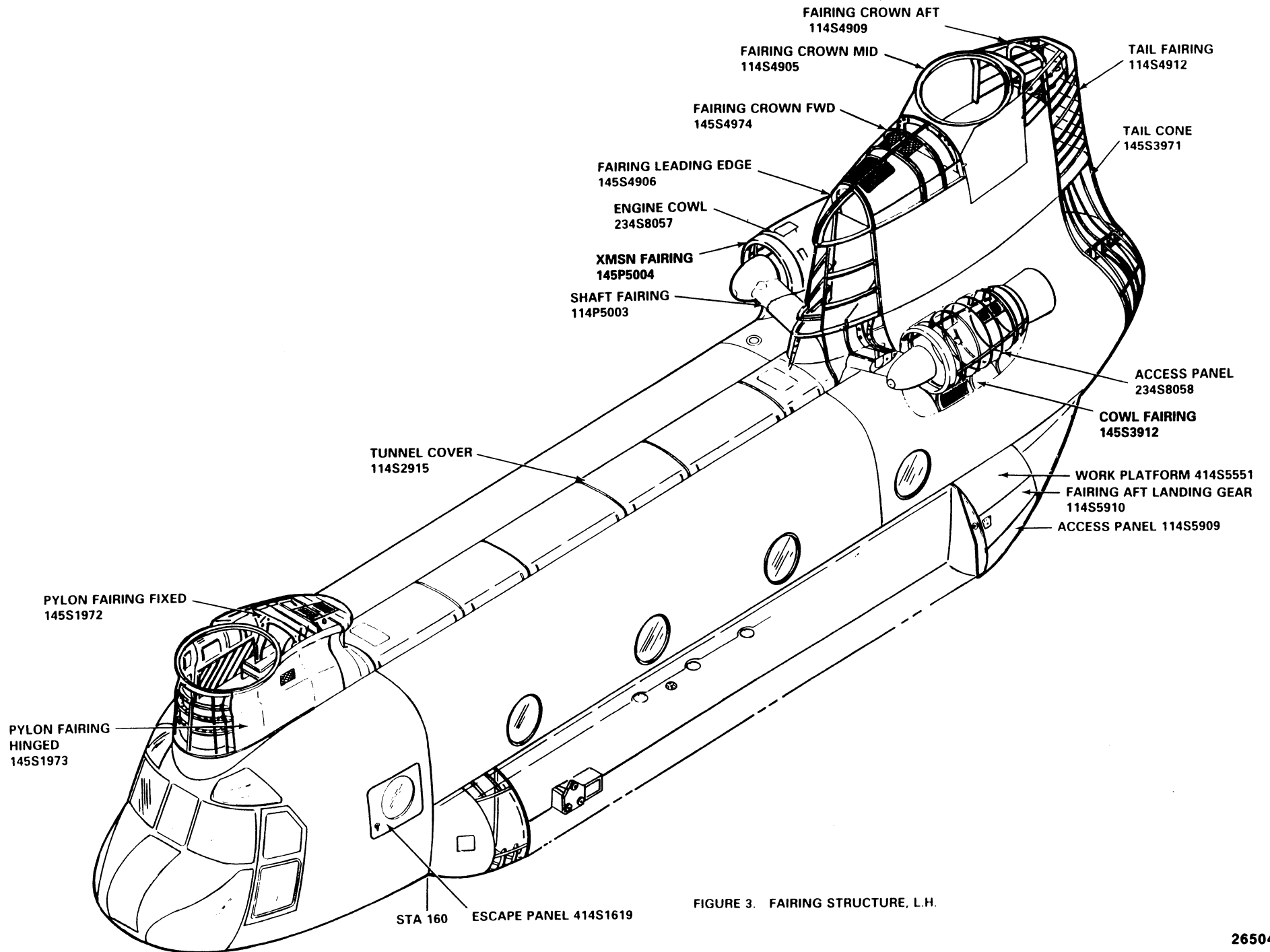

FIGURE 3. FAIRING STRUCTURE, L.H.

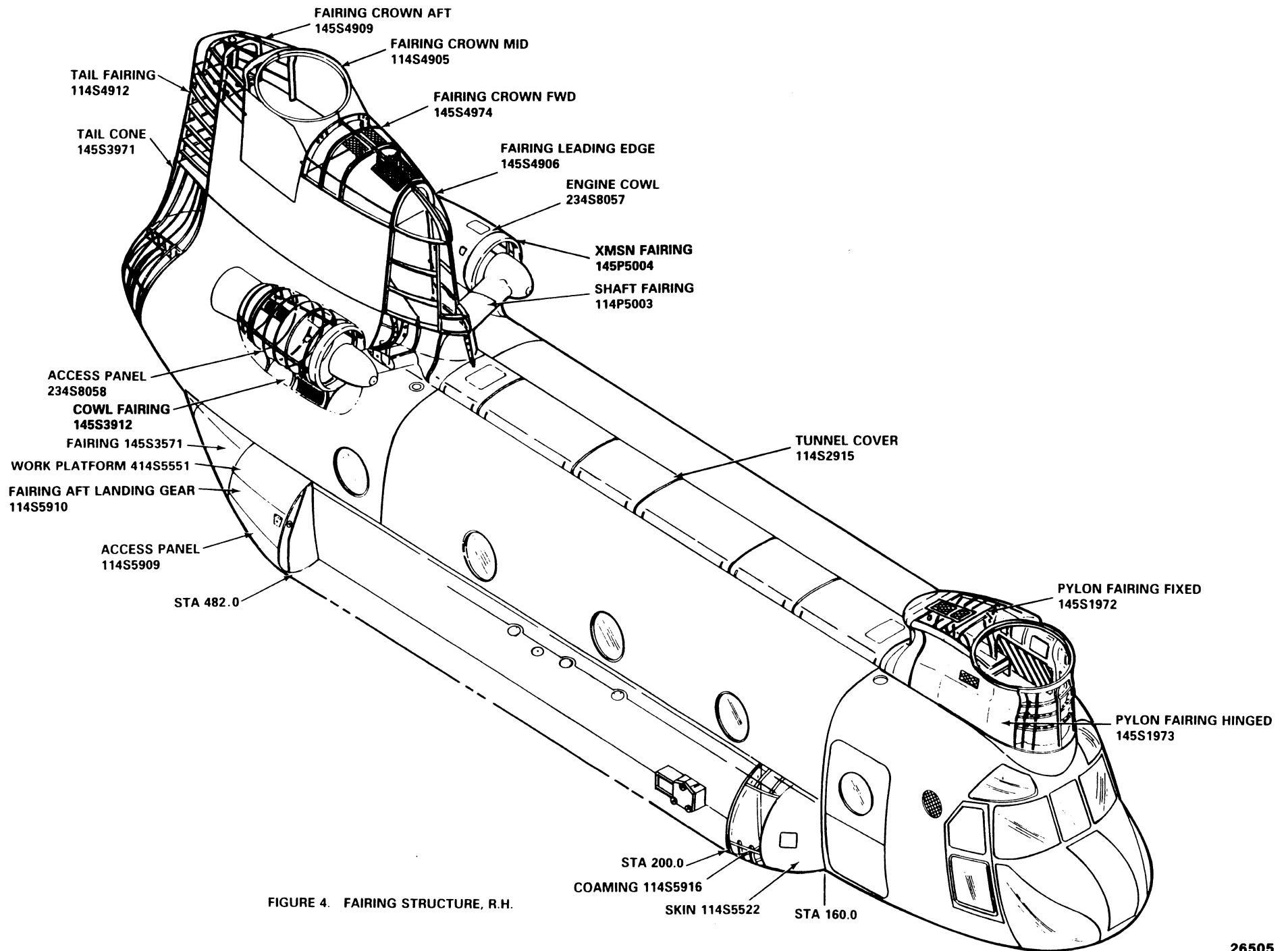

FIGURE 4. FAIRING STRUCTURE, R.H.

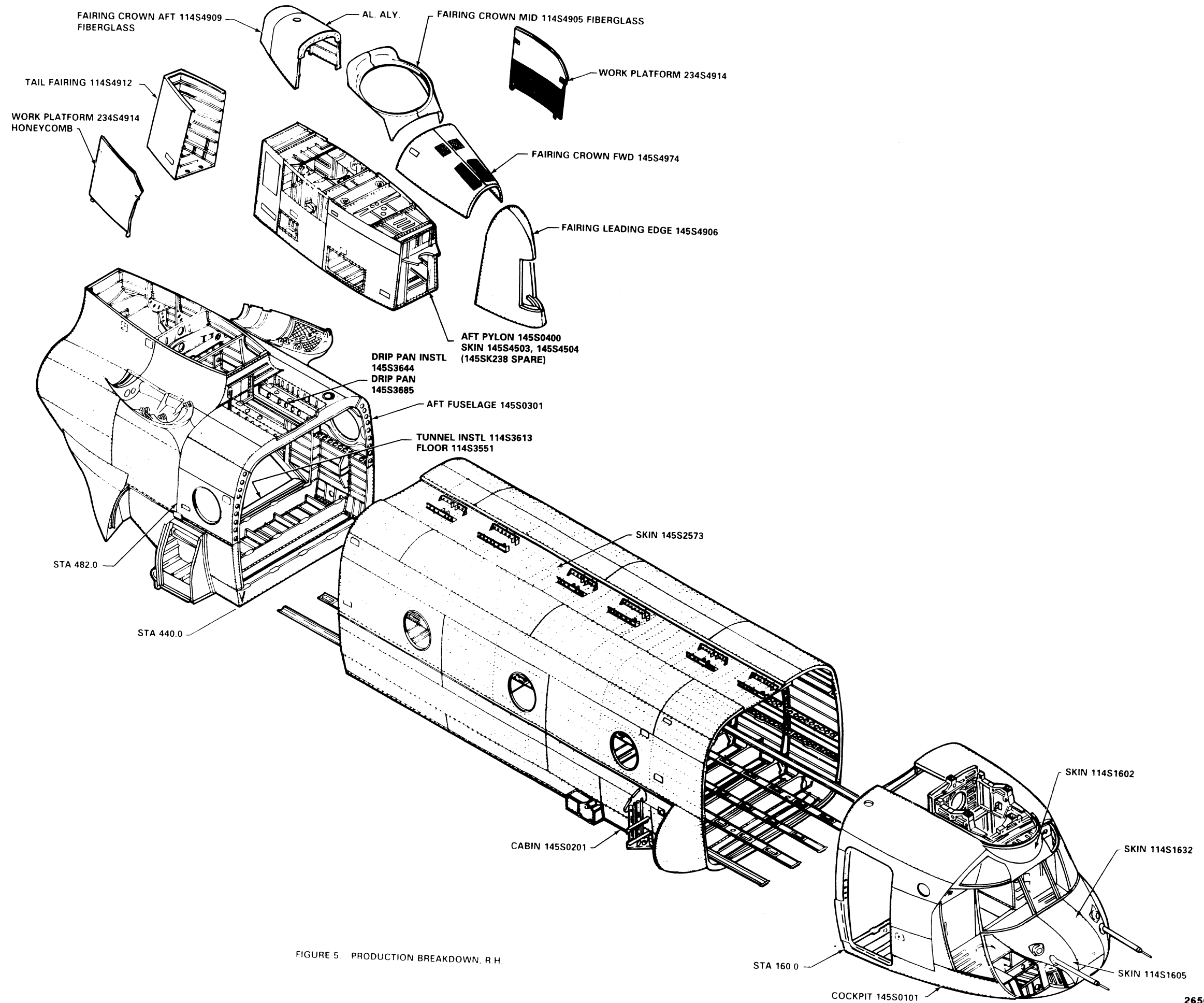

FIGURE 5. PRODUCTION BREAKDOWN, R H

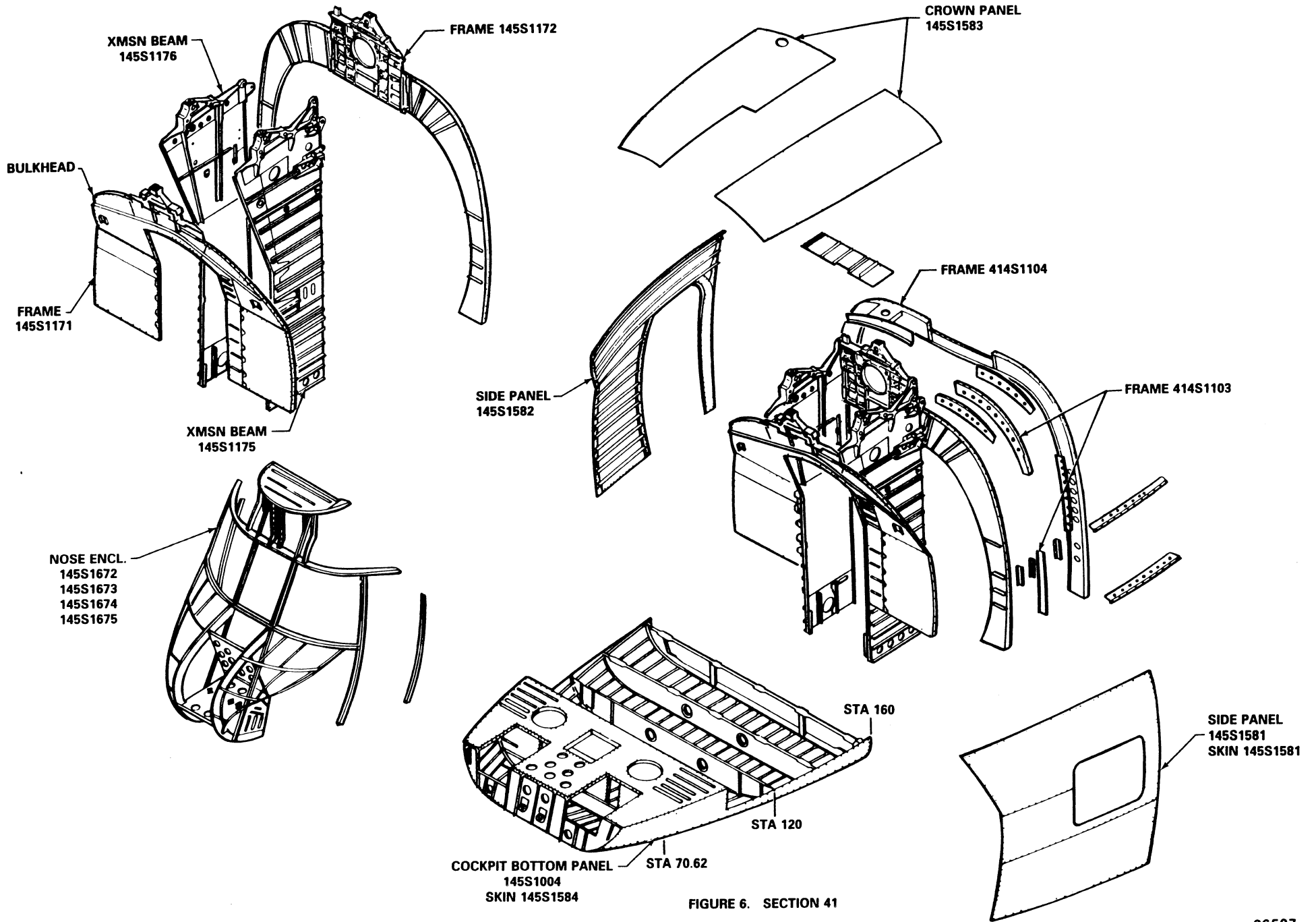

FIGURE 6. SECTION 41

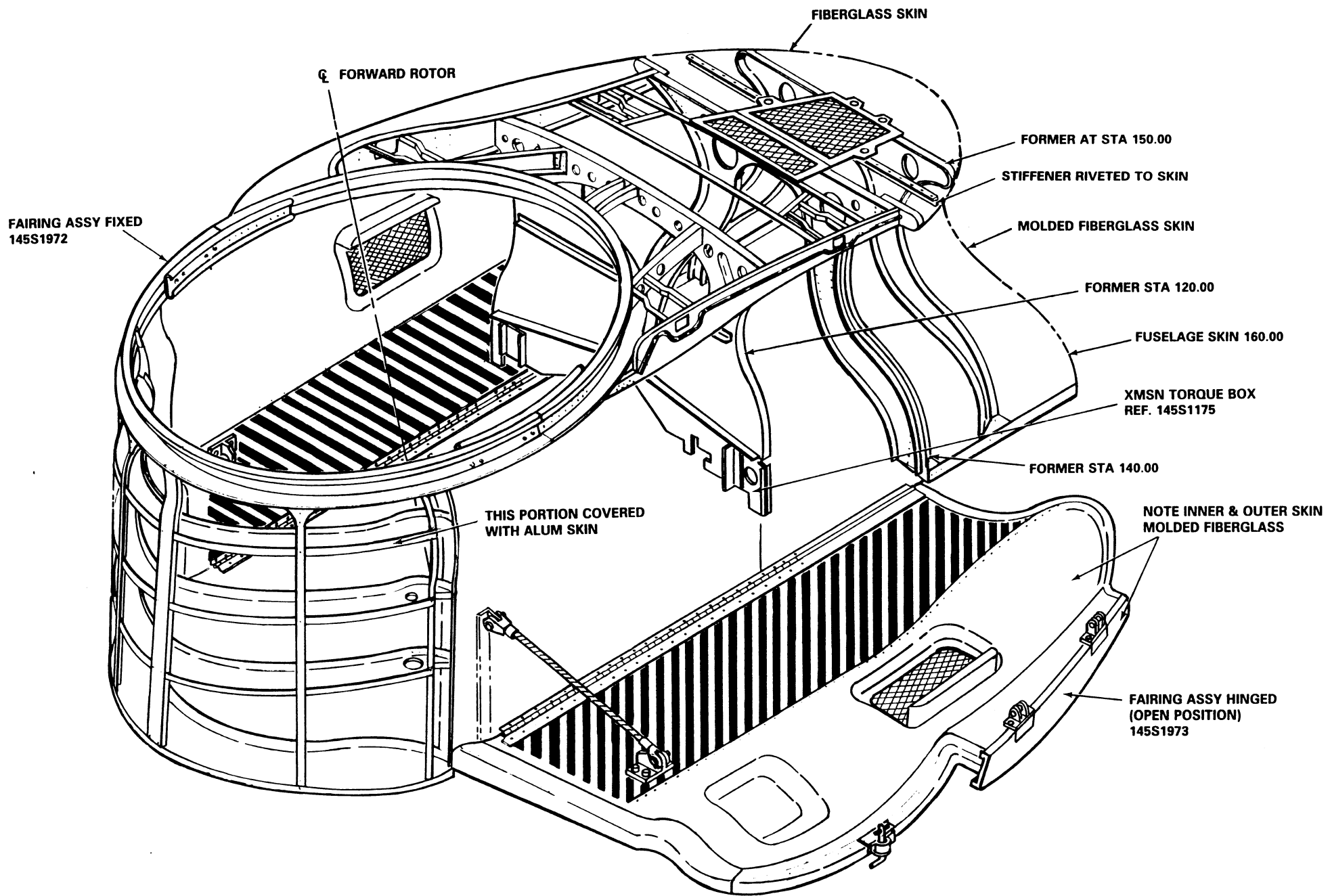

FIGURE 7. FORWARD PYLON

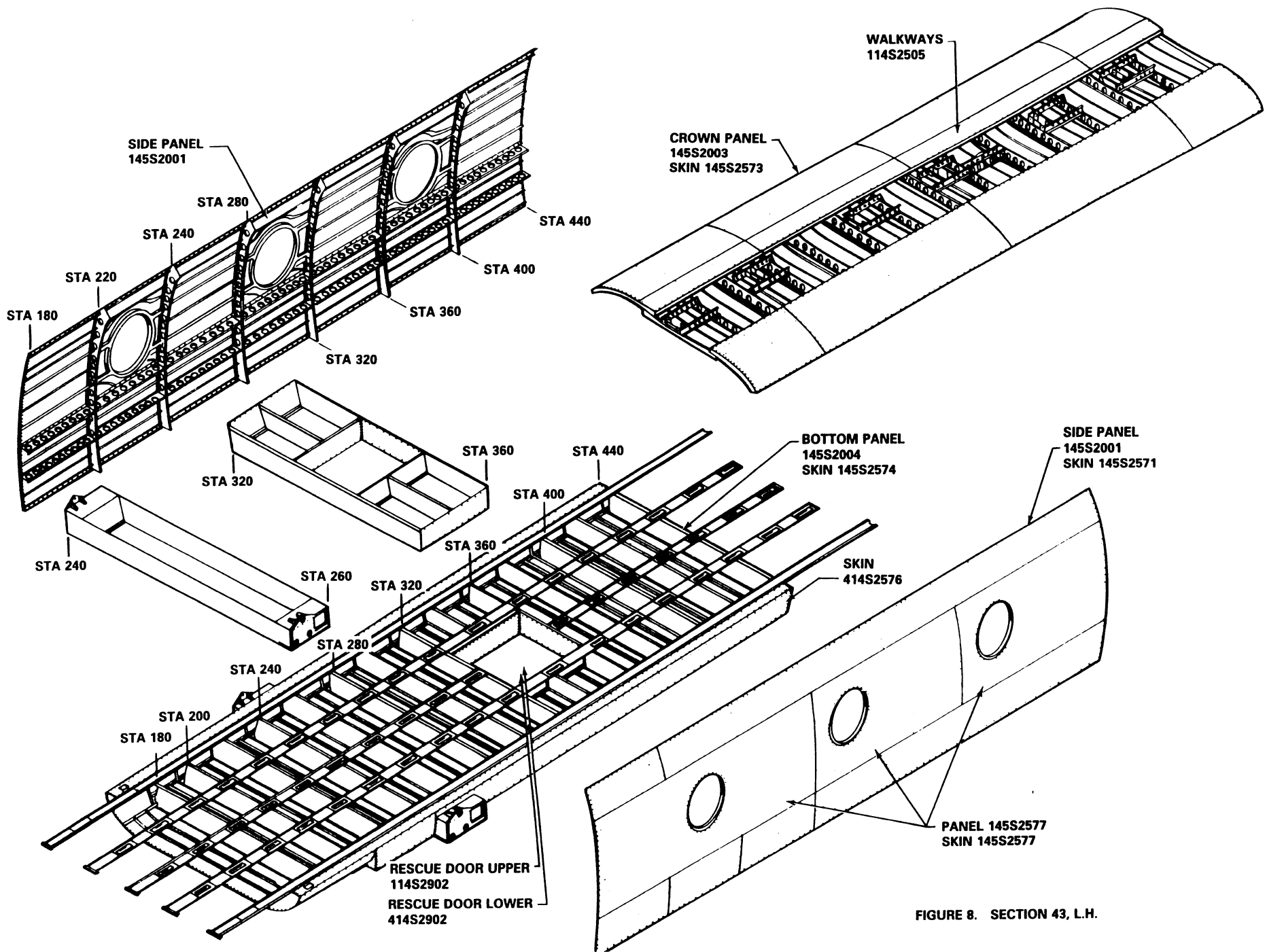

FIGURE 8. SECTION 43, L.H.

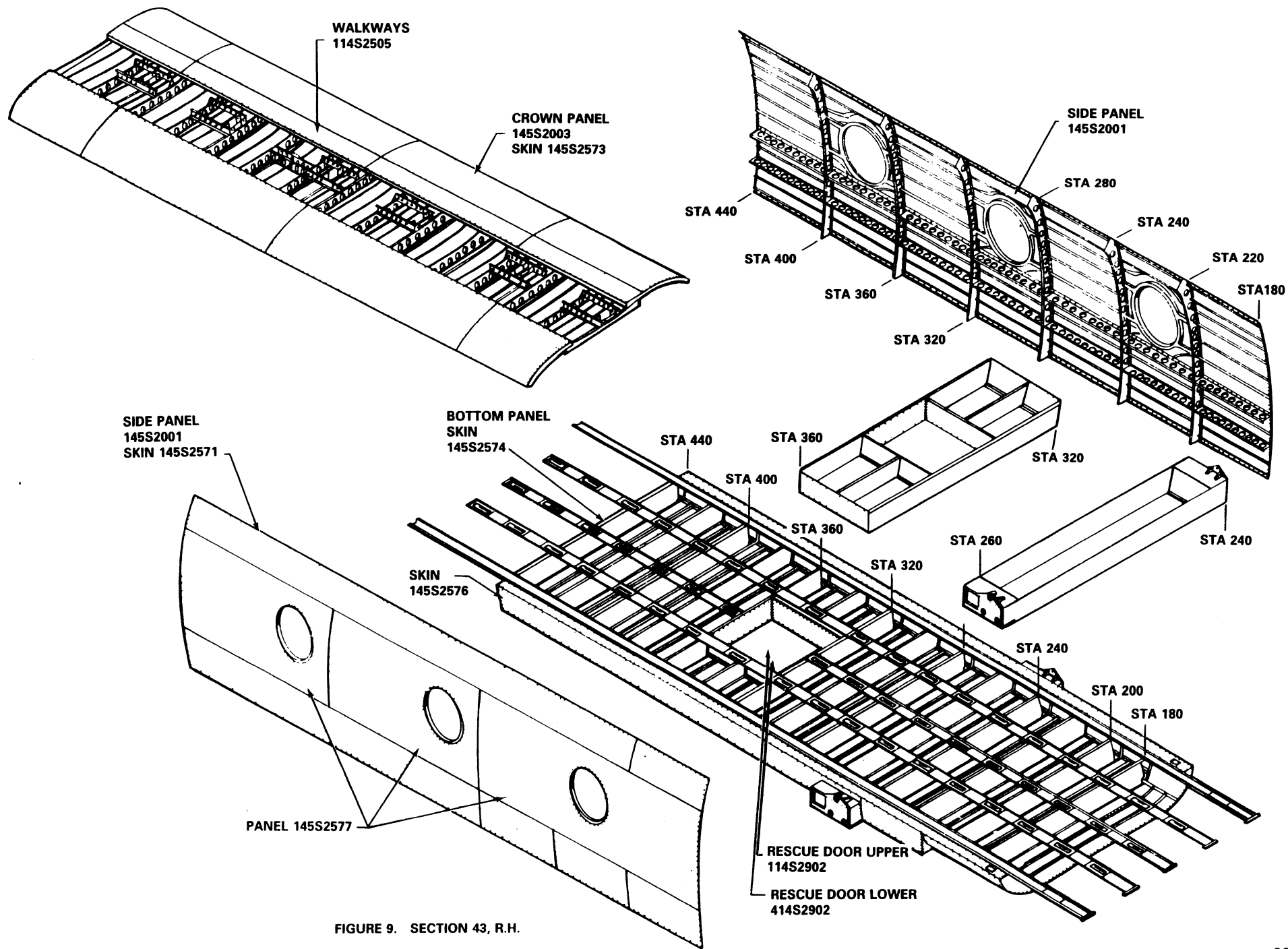

FIGURE 9. SECTION 43, R.H.

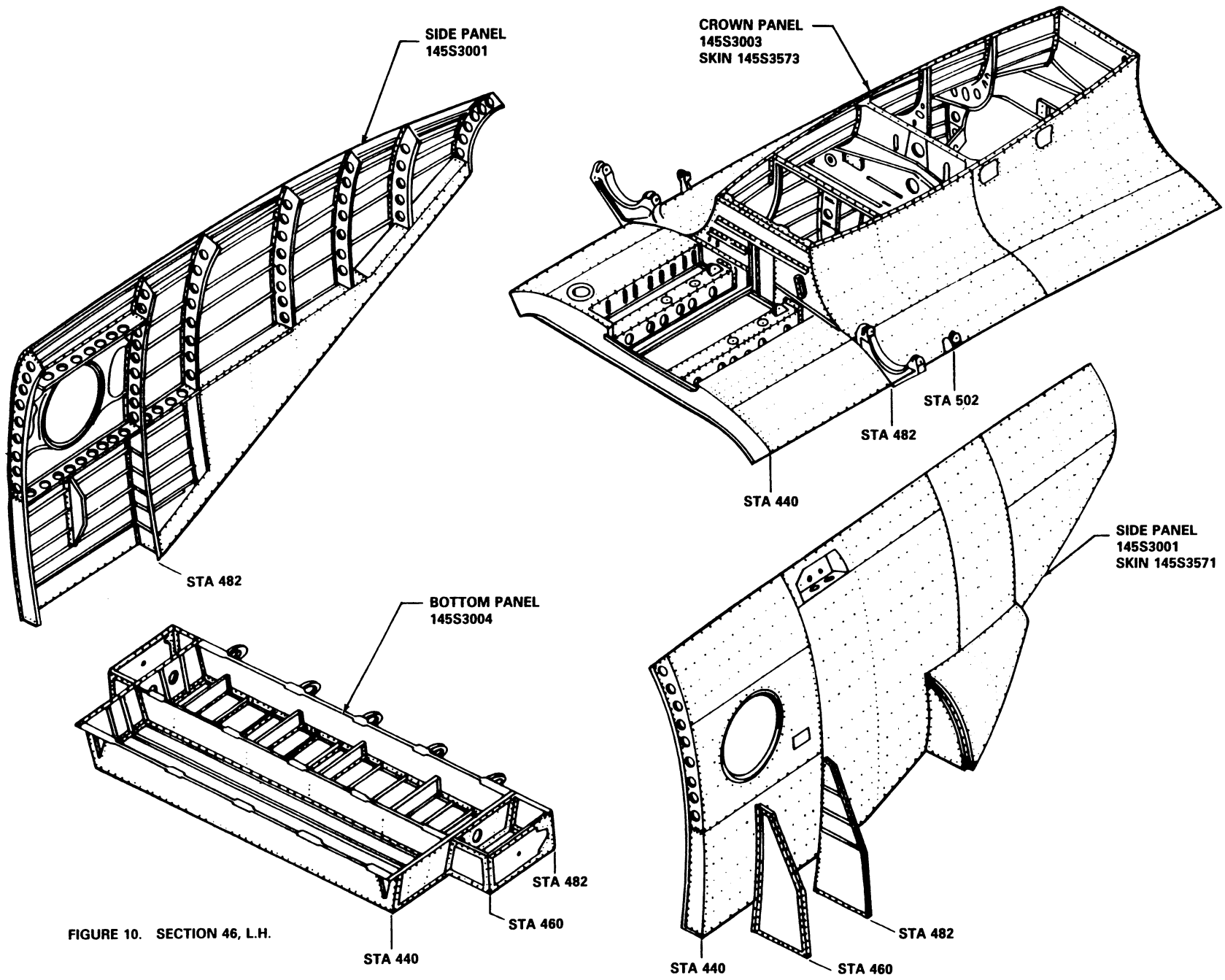

FIGURE 10. SECTION 46, L.H.

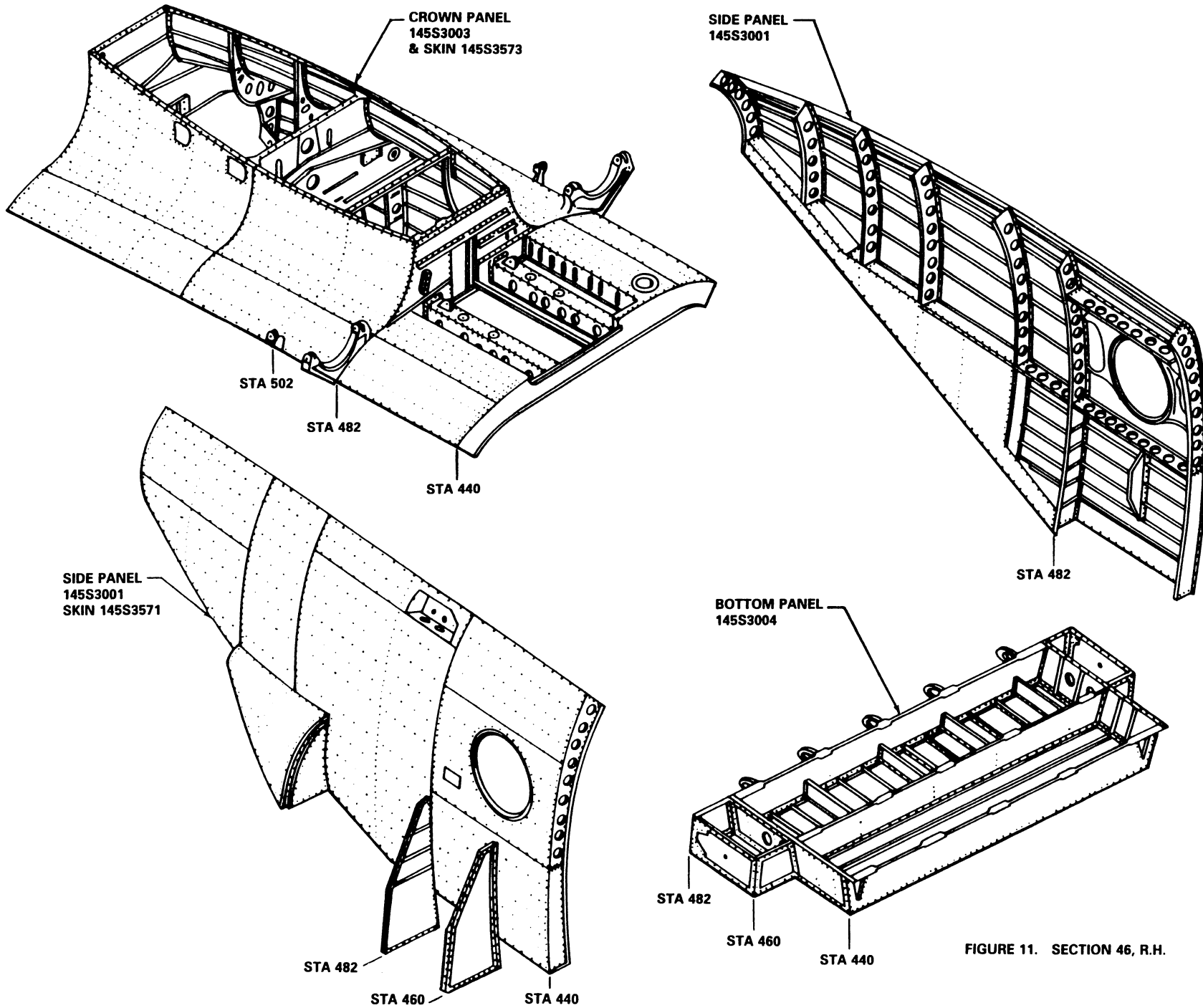

FIGURE 11. SECTION 46, R.H.

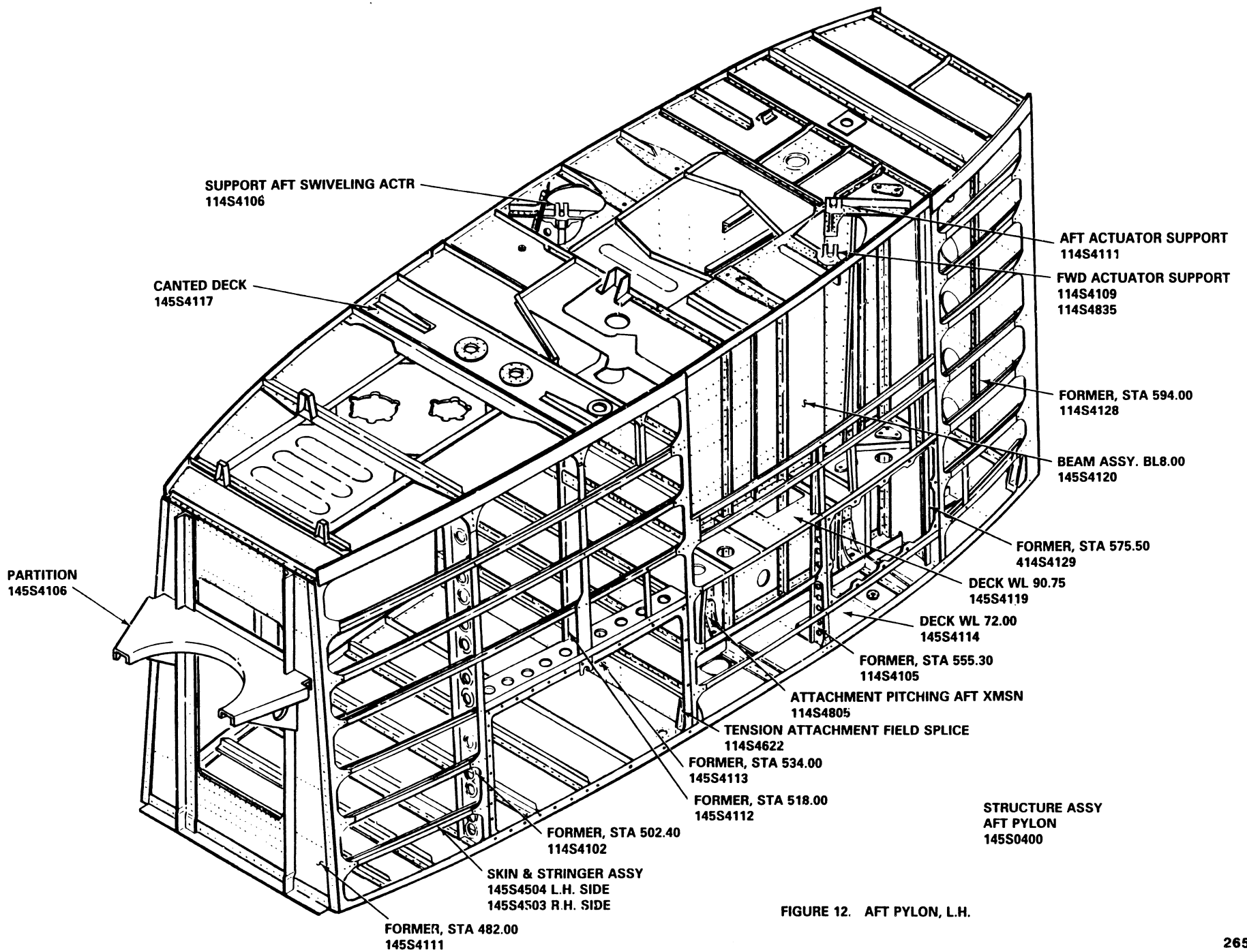

FIGURE 12. AFT PYLON, L.H.

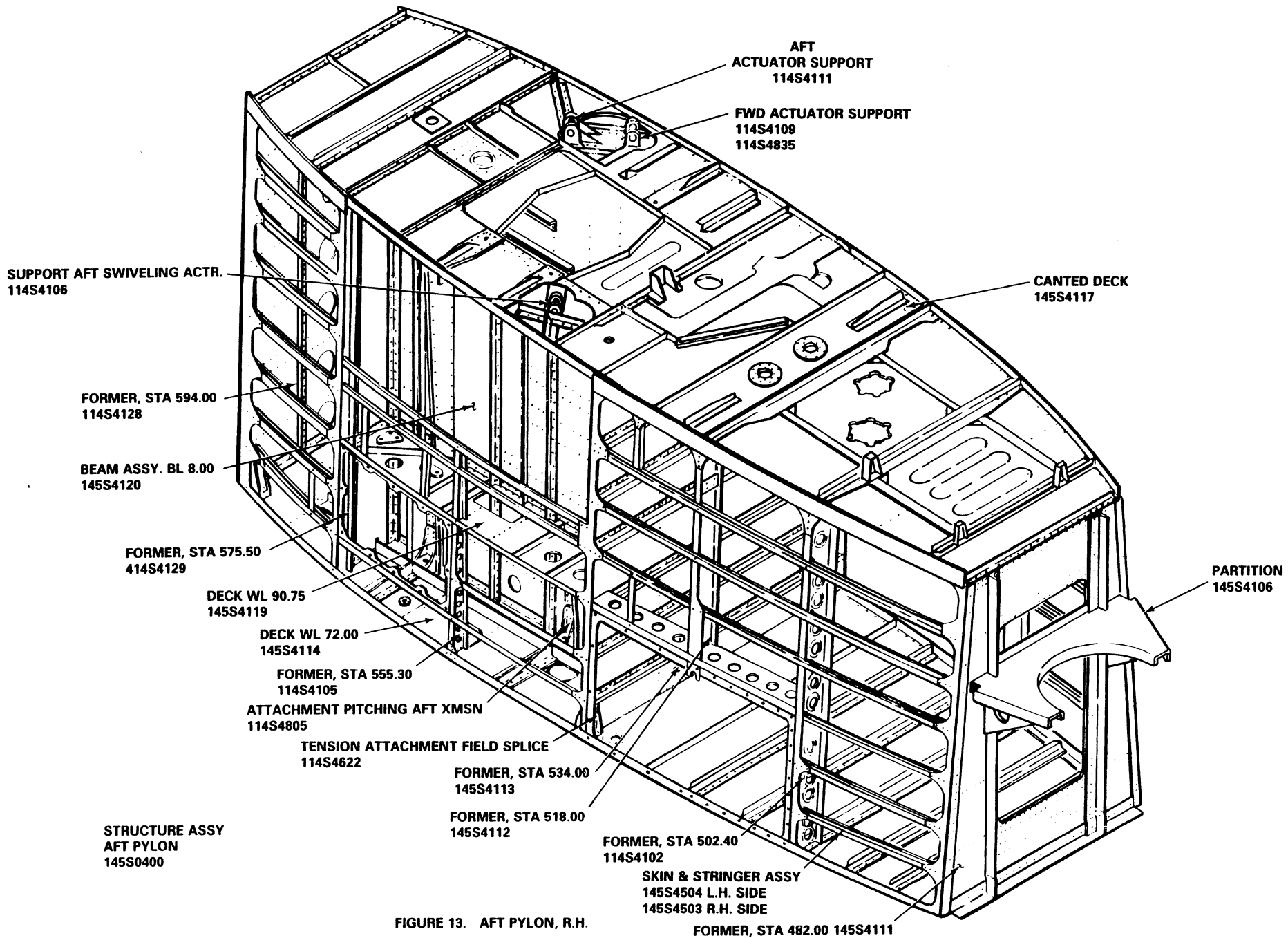

FIGURE 13. AFT PYLON, R.H.

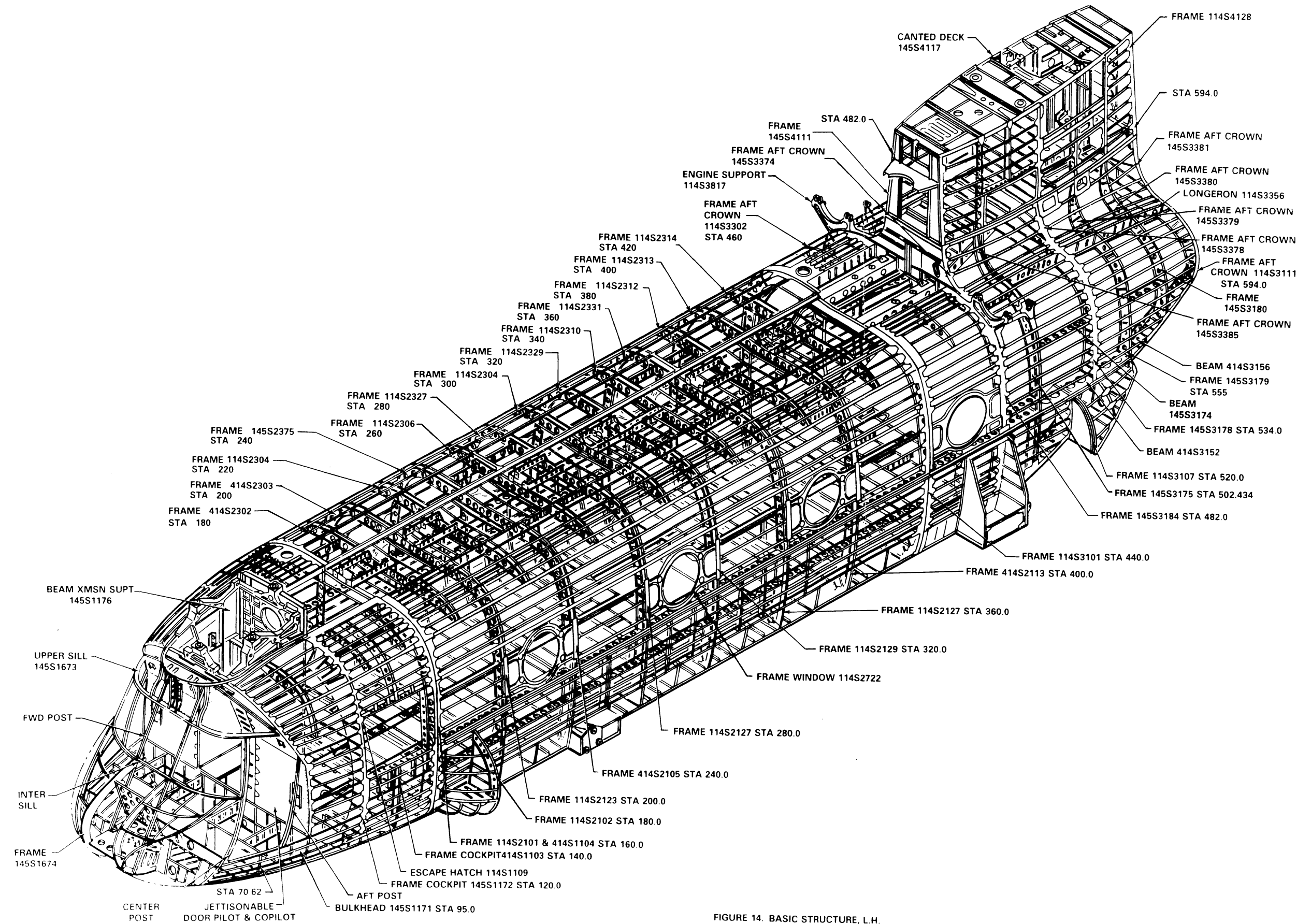

FIGURE 14. BASIC STRUCTURE, L.H.

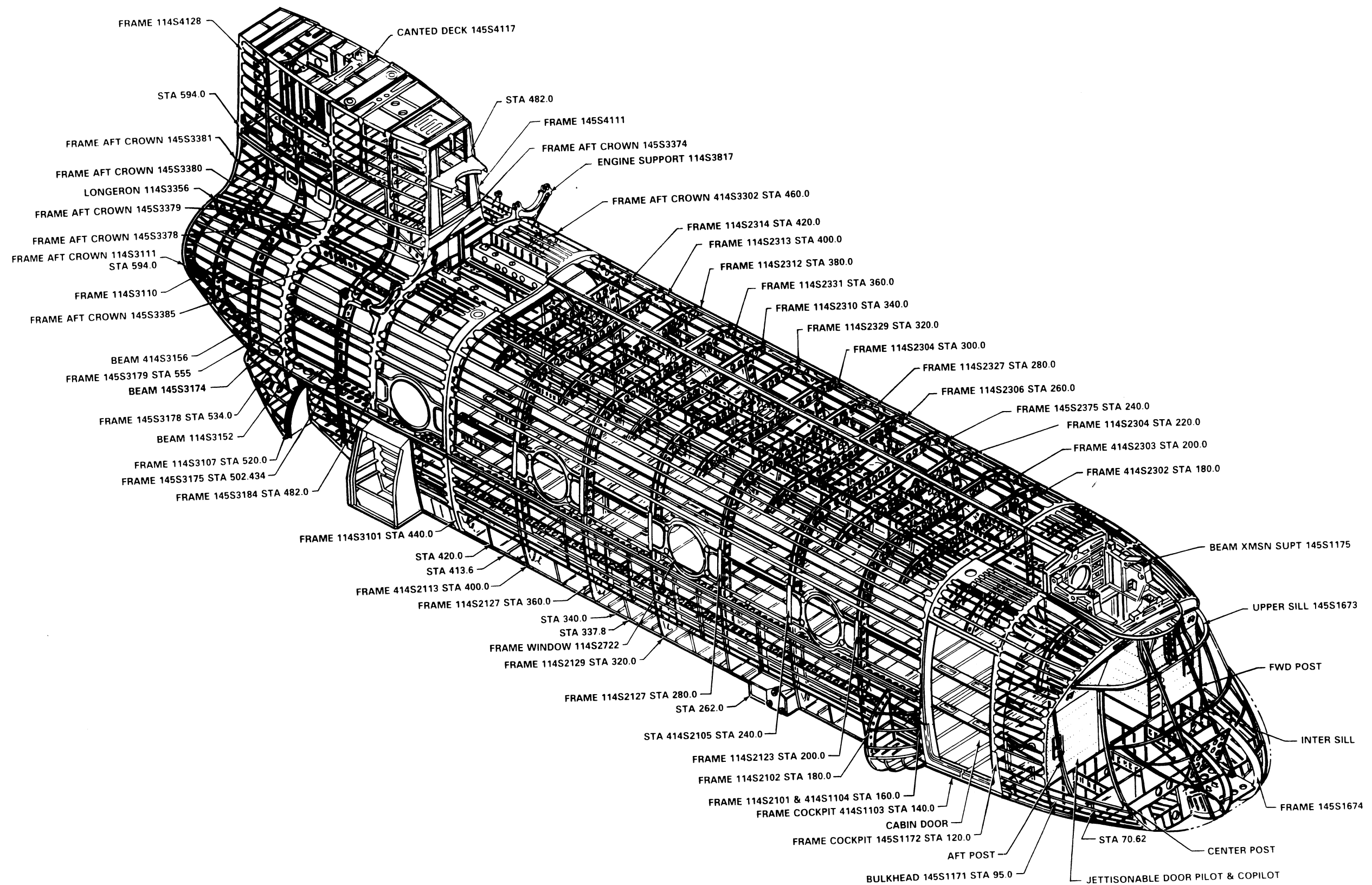

FIGURE 15. BASIC STRUCTURE. R.H.

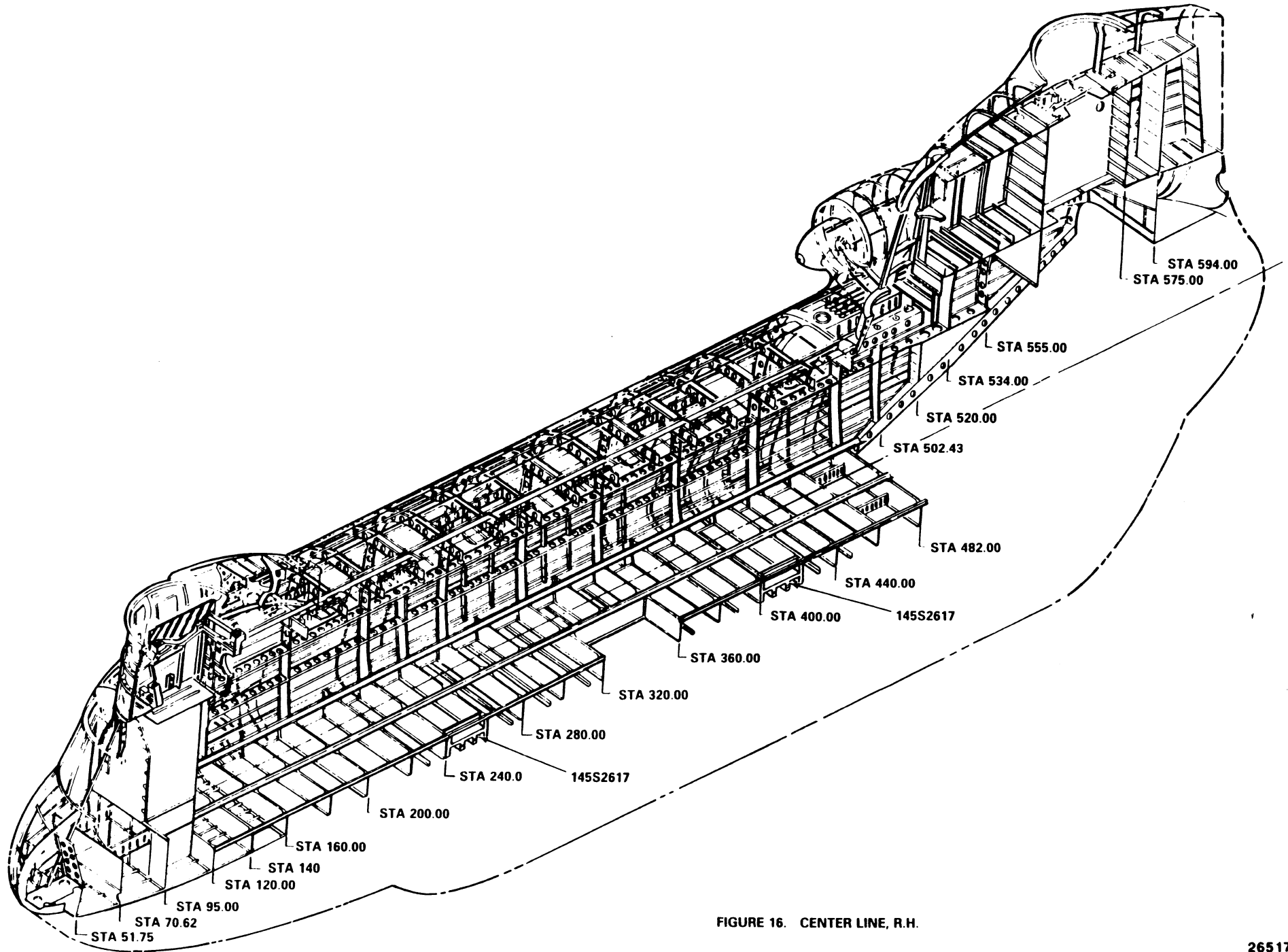

FIGURE 16. CENTER LINE, R.H.

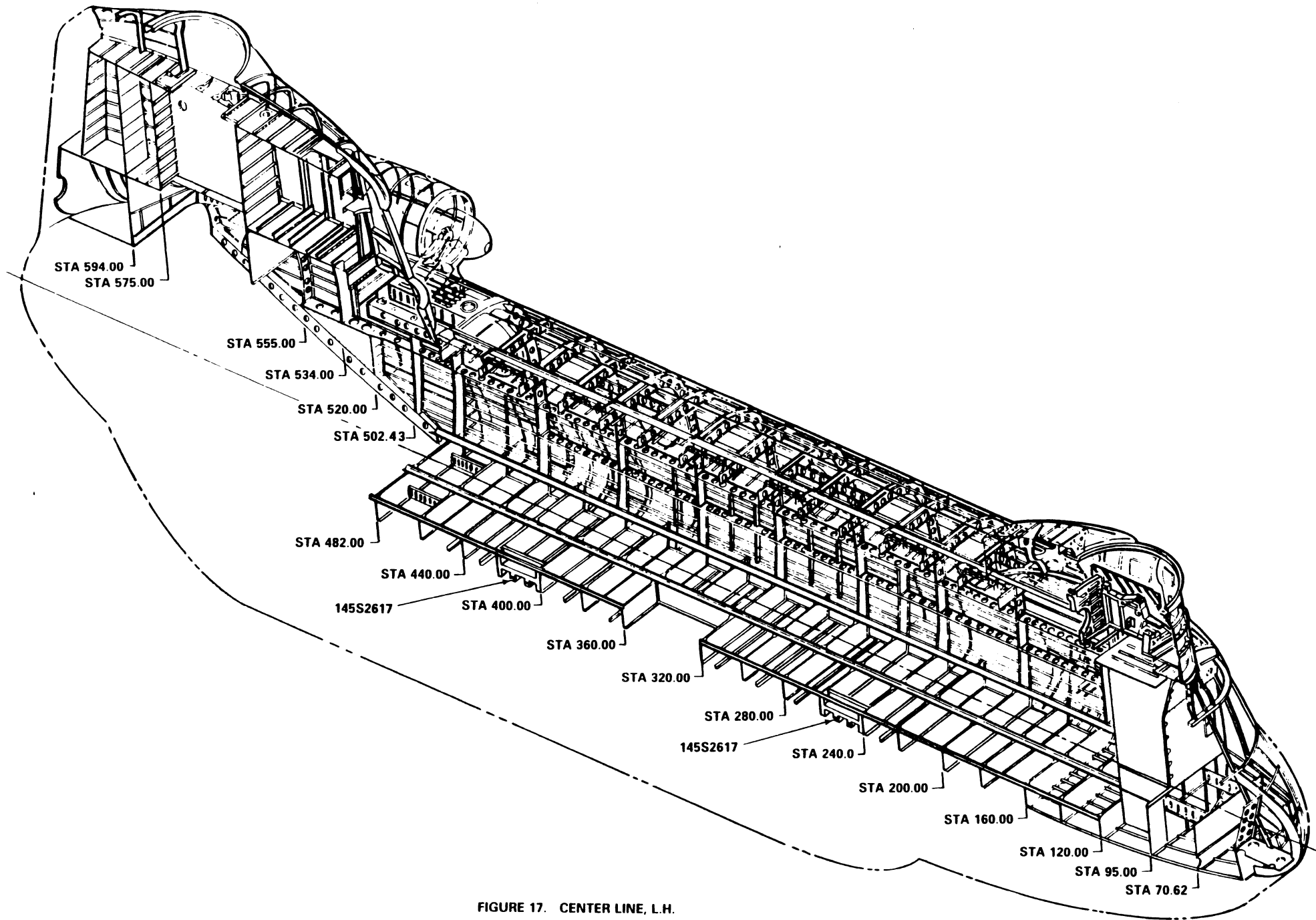

FIGURE 17. CENTER LINE, L.H.

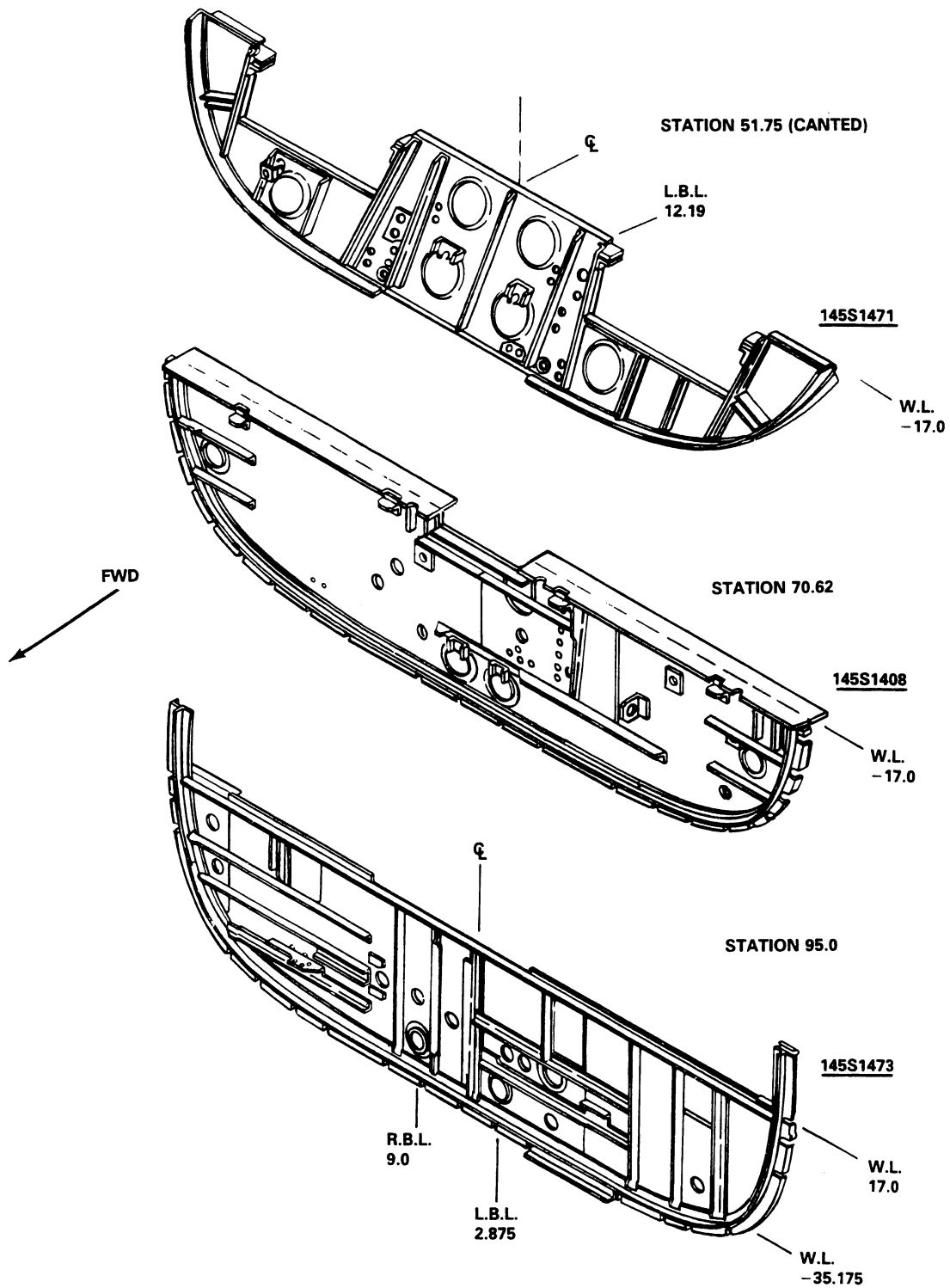

FIGURE 18. FORMER STATIONS 51.75, 70.62 & 95.0

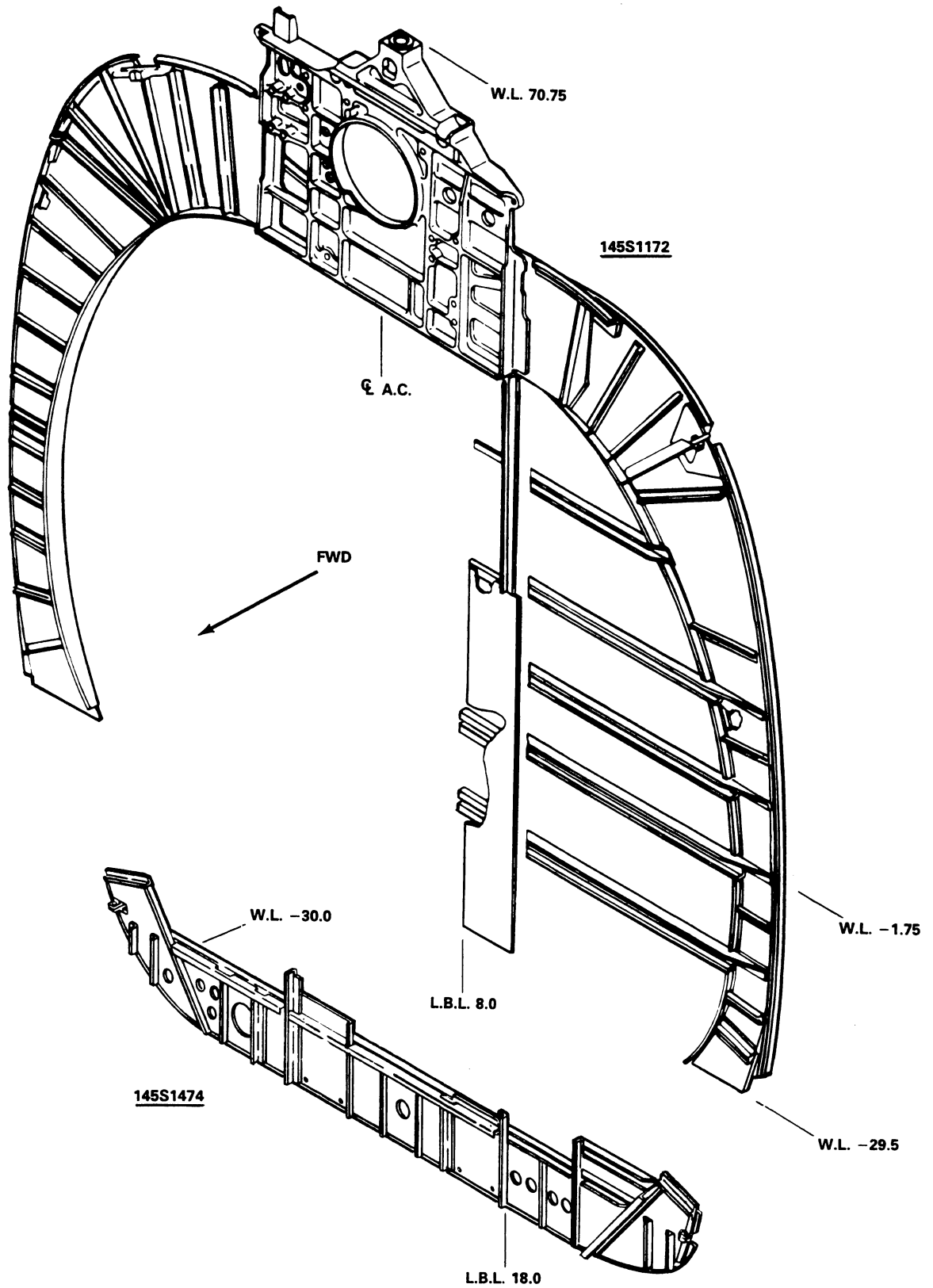

FIGURE 19. FORMER STATION 120

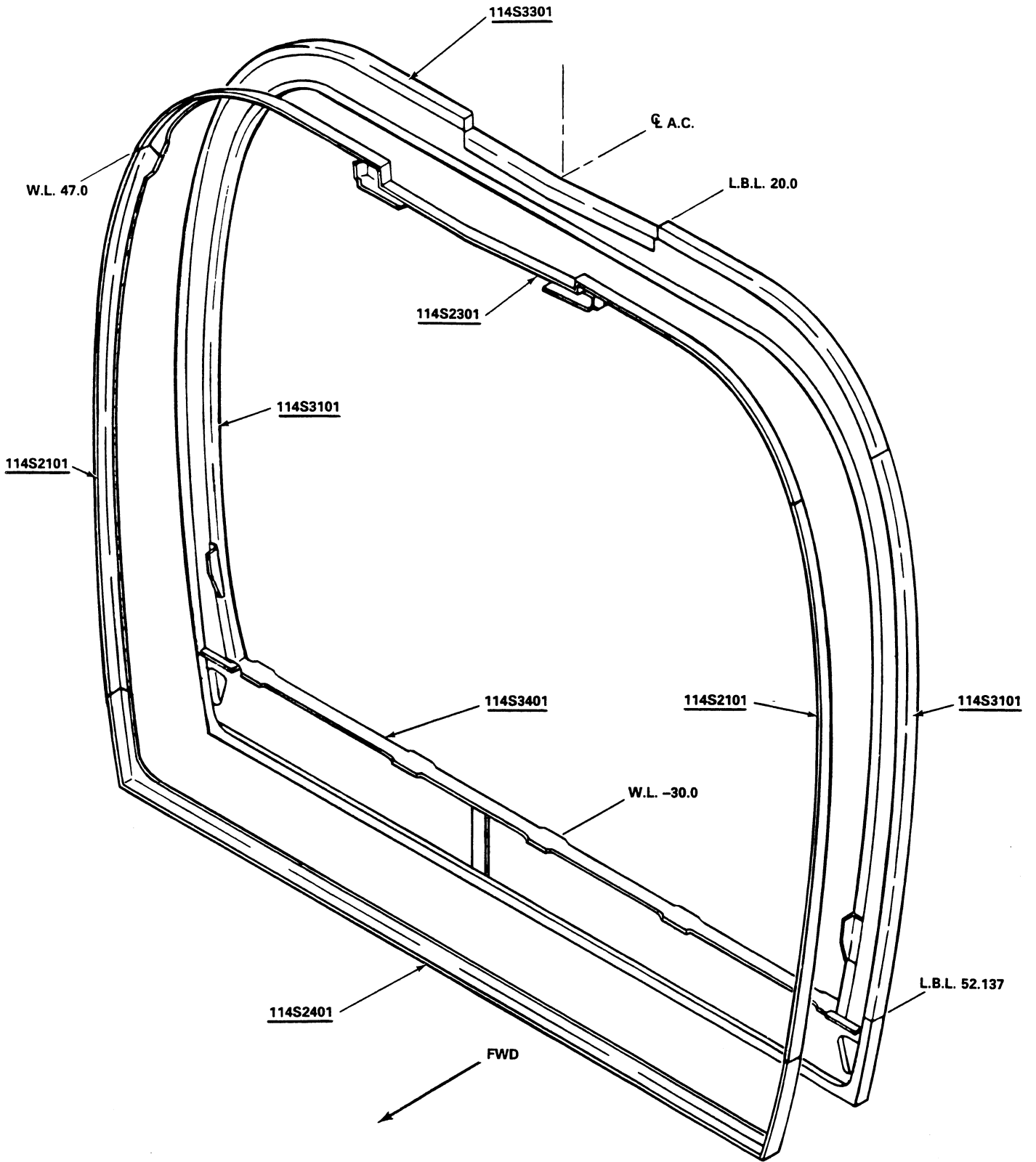

FIGURE 20. FORMER STATIONS 160 & 440

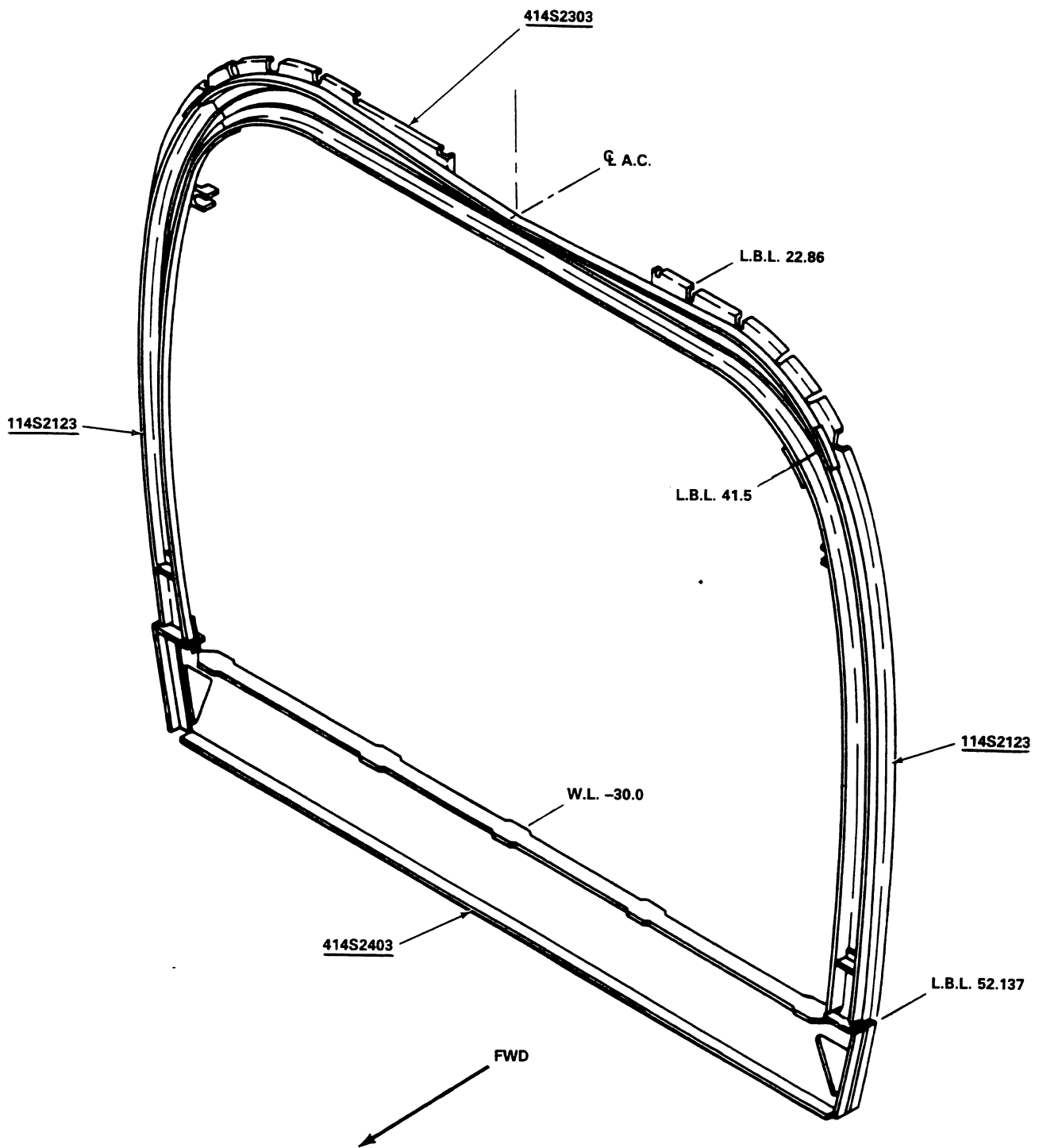

FIGURE 21. FORMER STATION 200

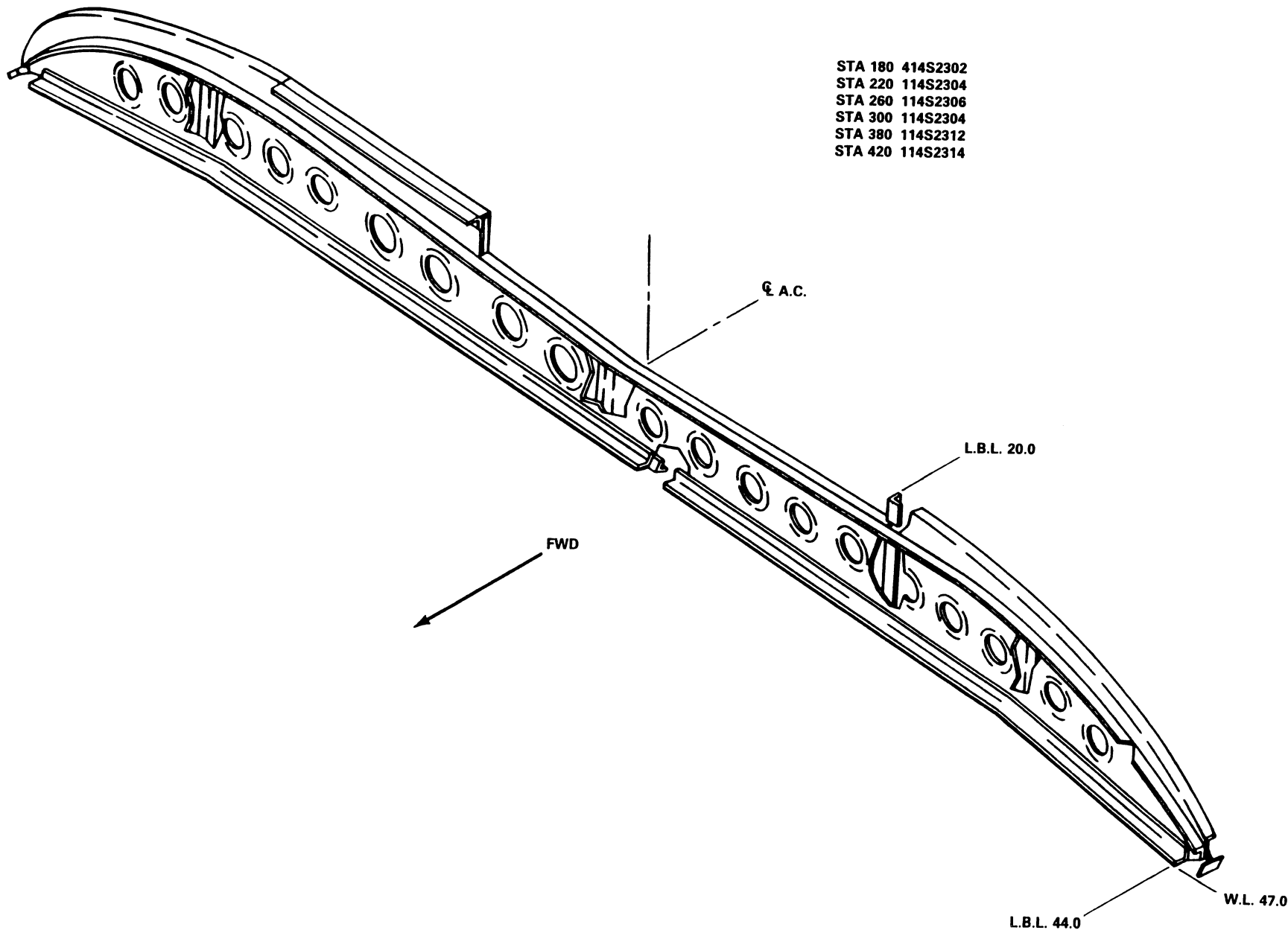

FIGURE 22. CROWN FORMER STATIONS 180, 220, 260, 300, 380 & 420

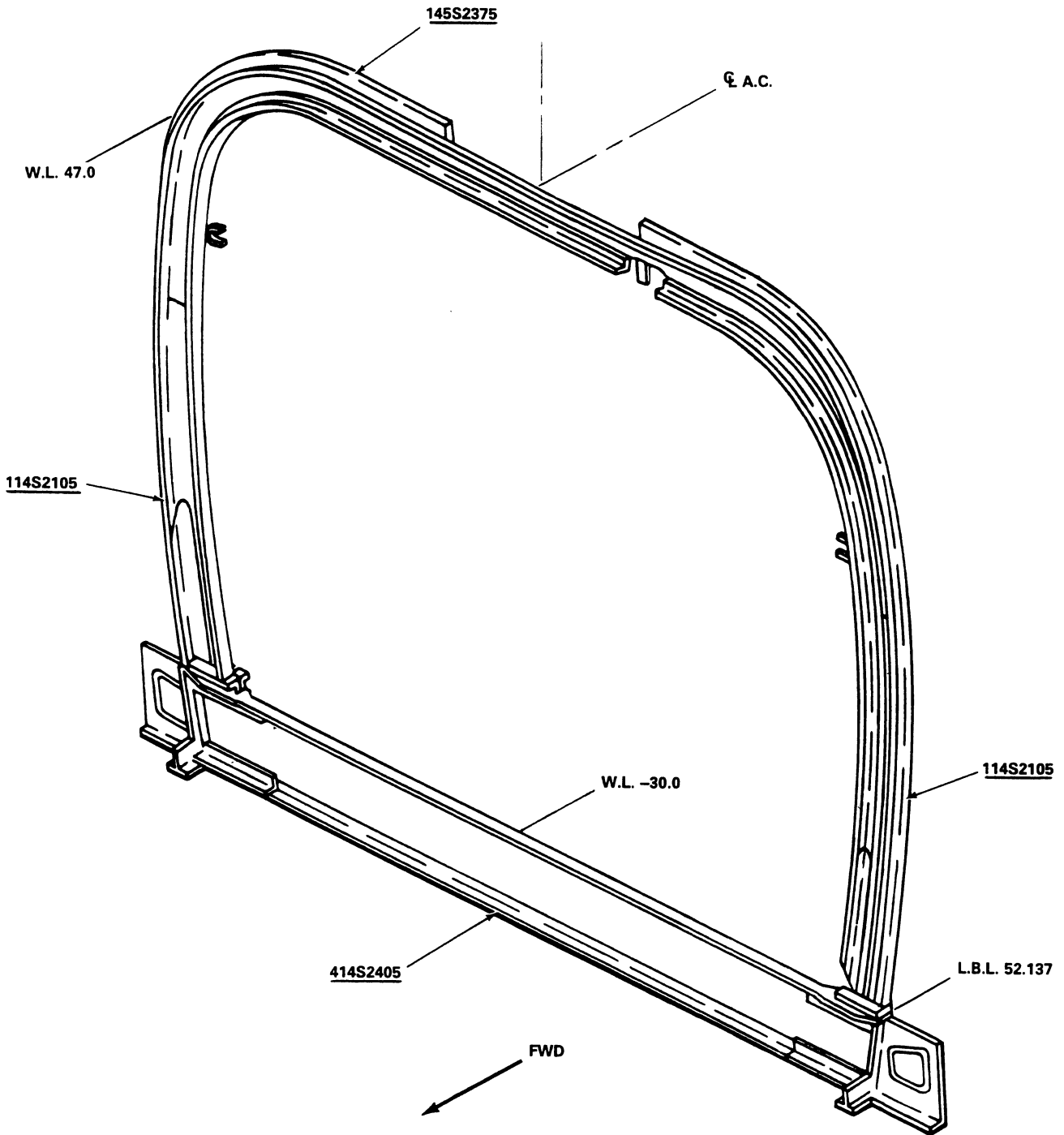

FIGURE 23. FORMER STATION 240

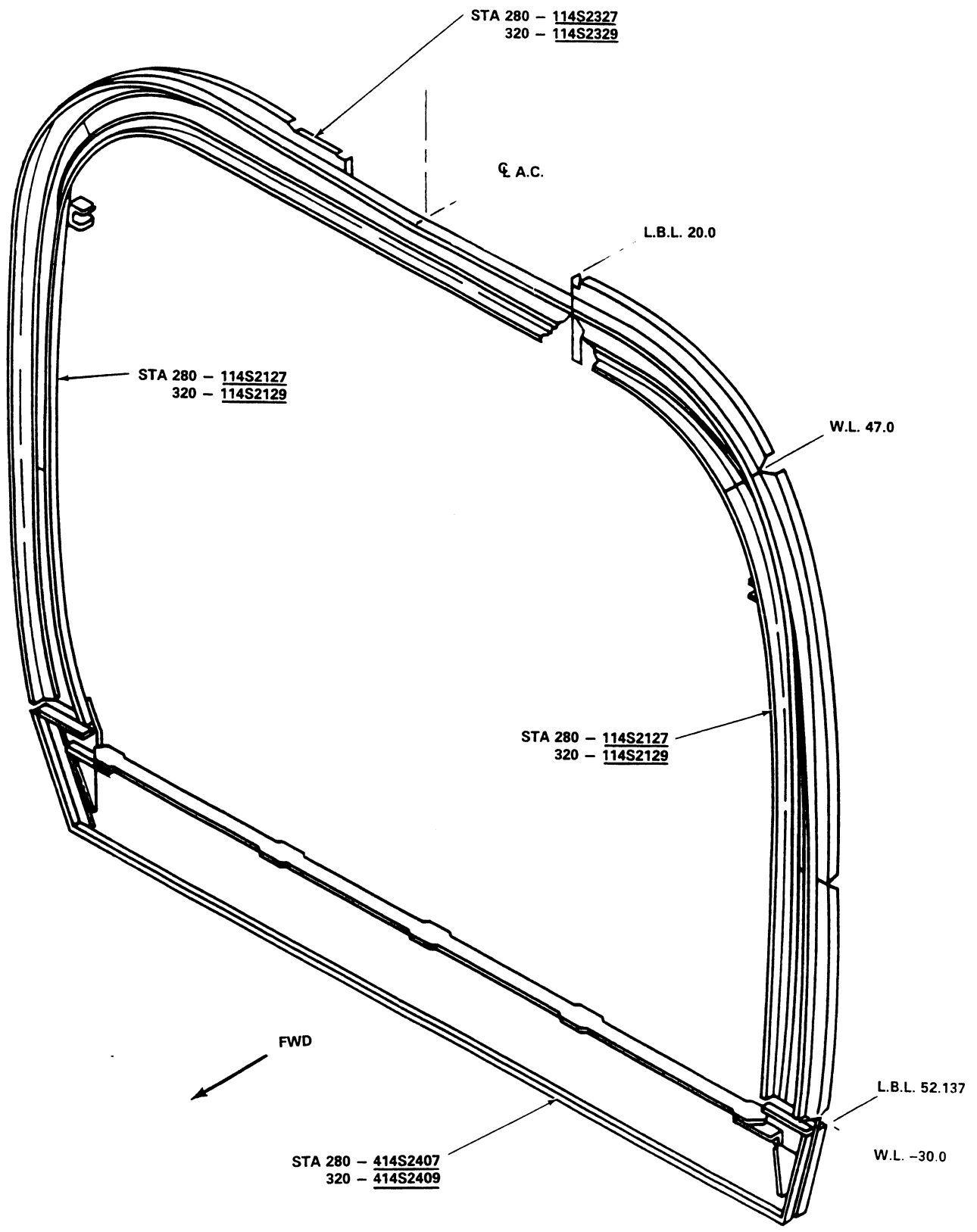

FIGURE 24. FORMER STATIONS 280 & 320

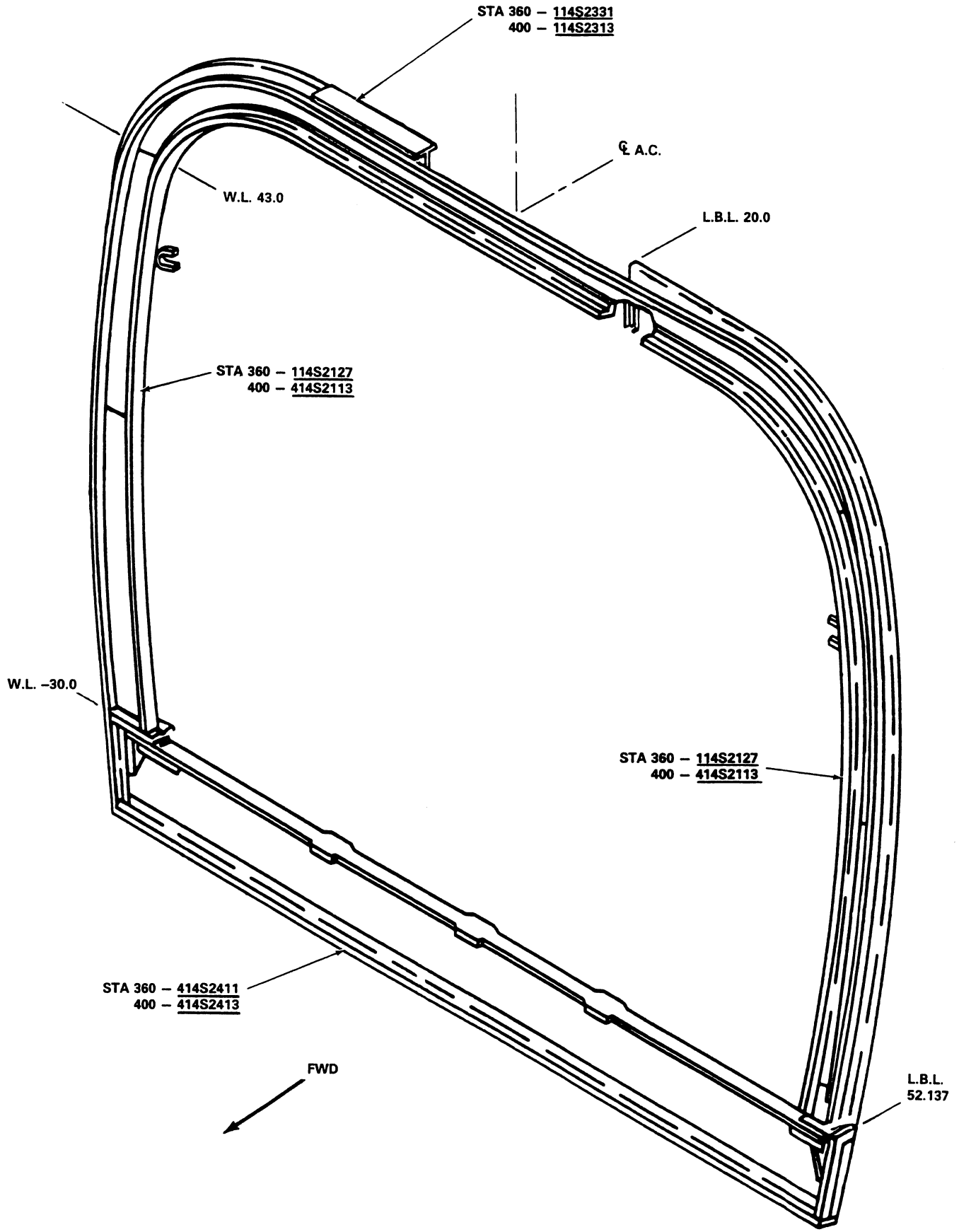

FIGURE 25. FORMER STATIONS 360 & 400

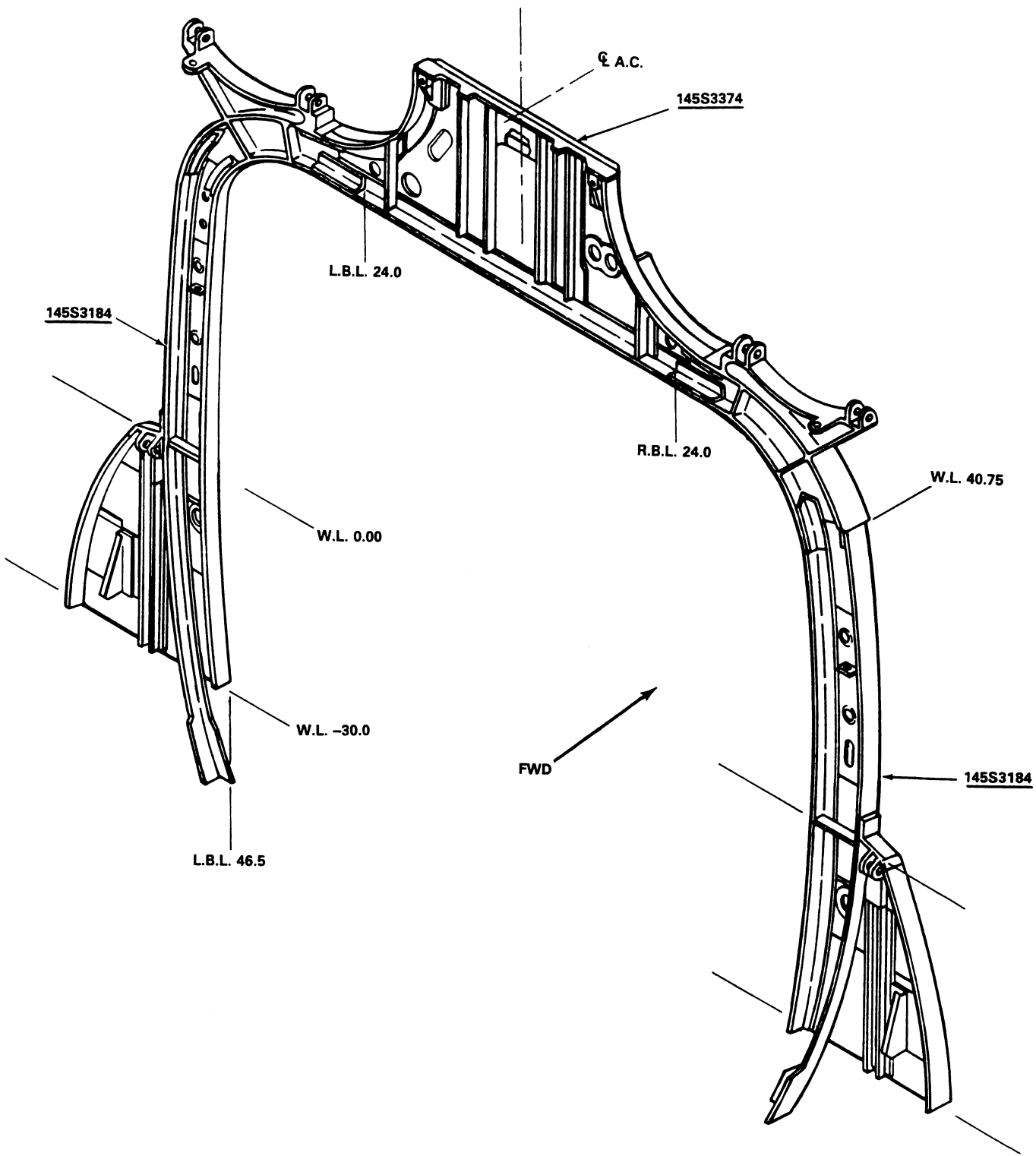

FIGURE 26. FORMER STATION 482

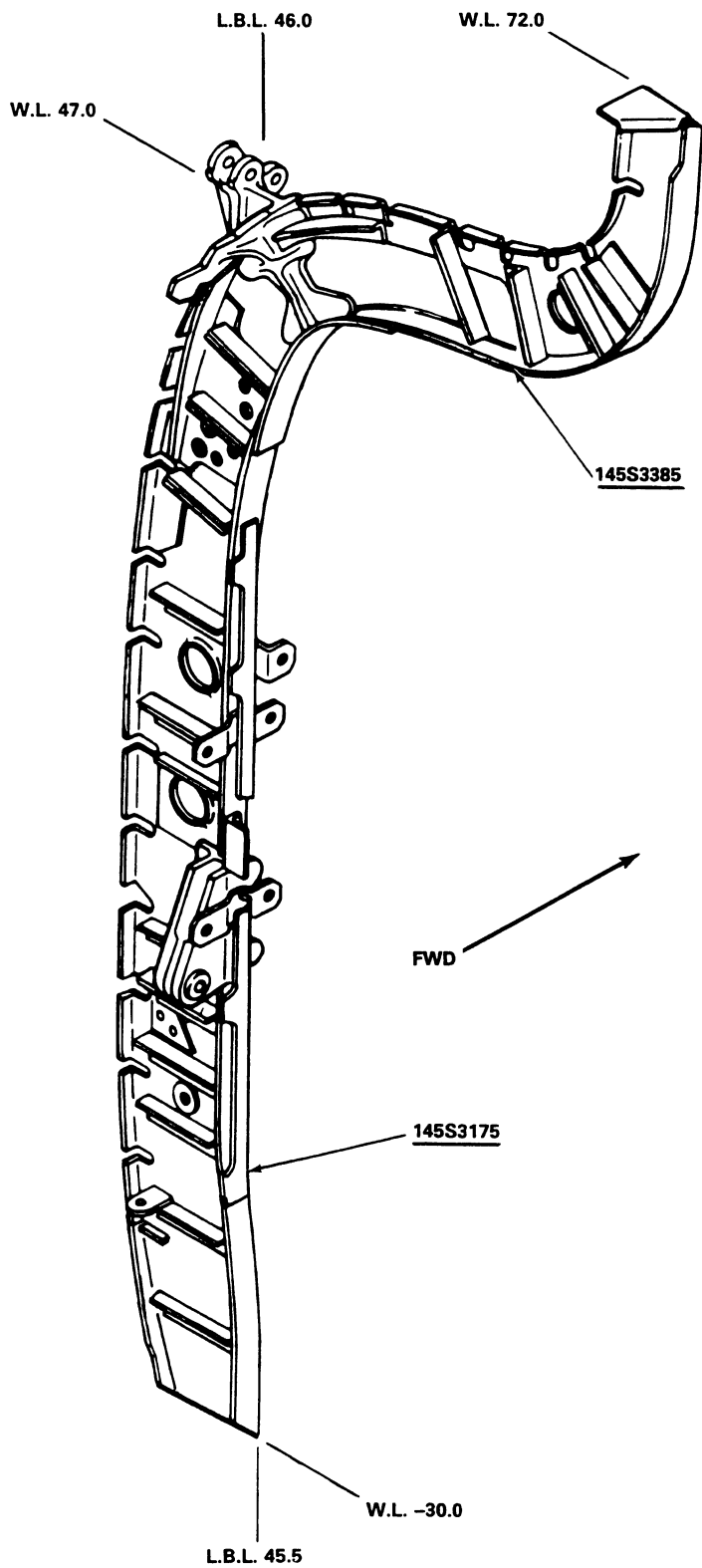

FIGURE 27. FORMER STATION 502.437

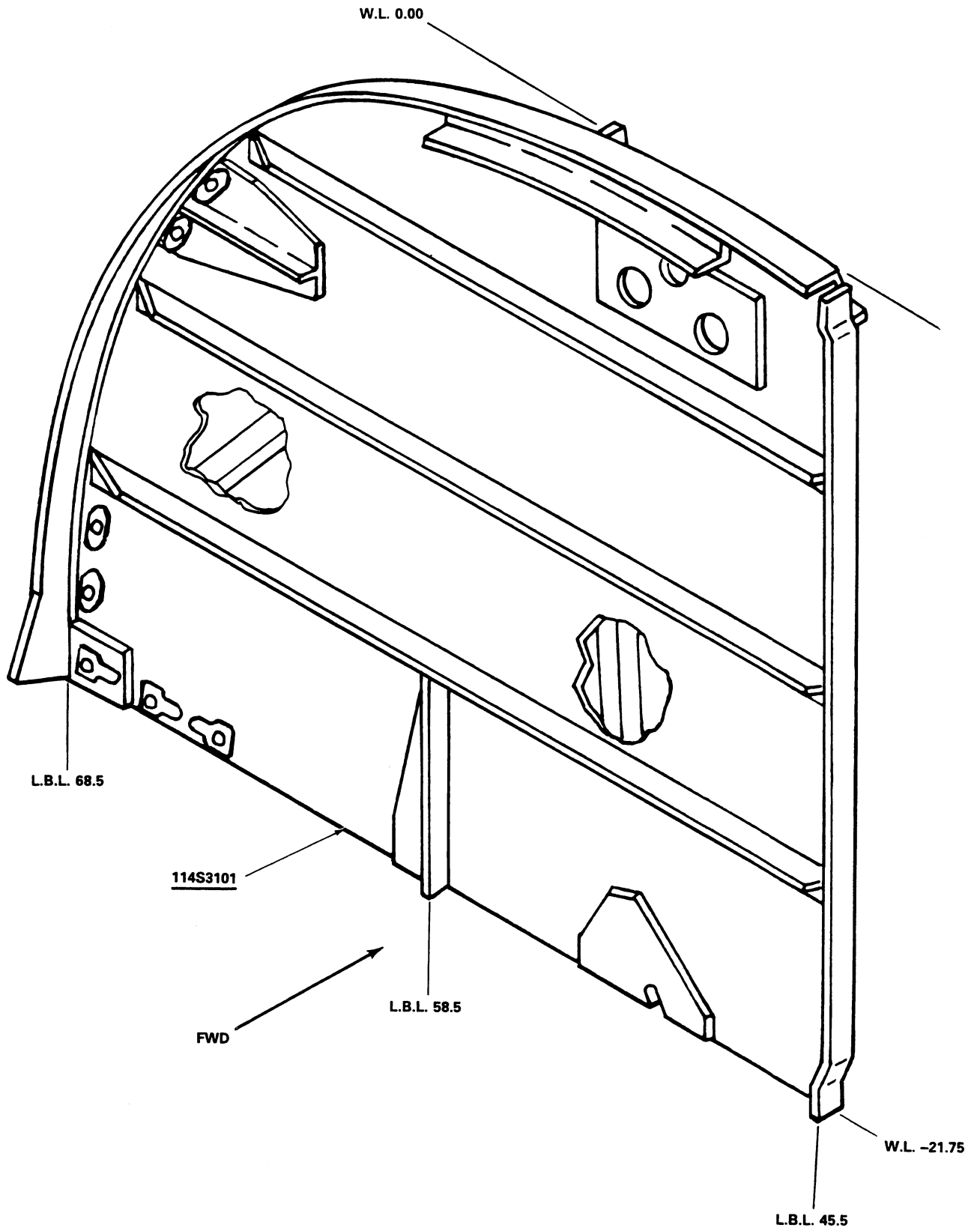

FIGURE 28. FORMER STATION 520

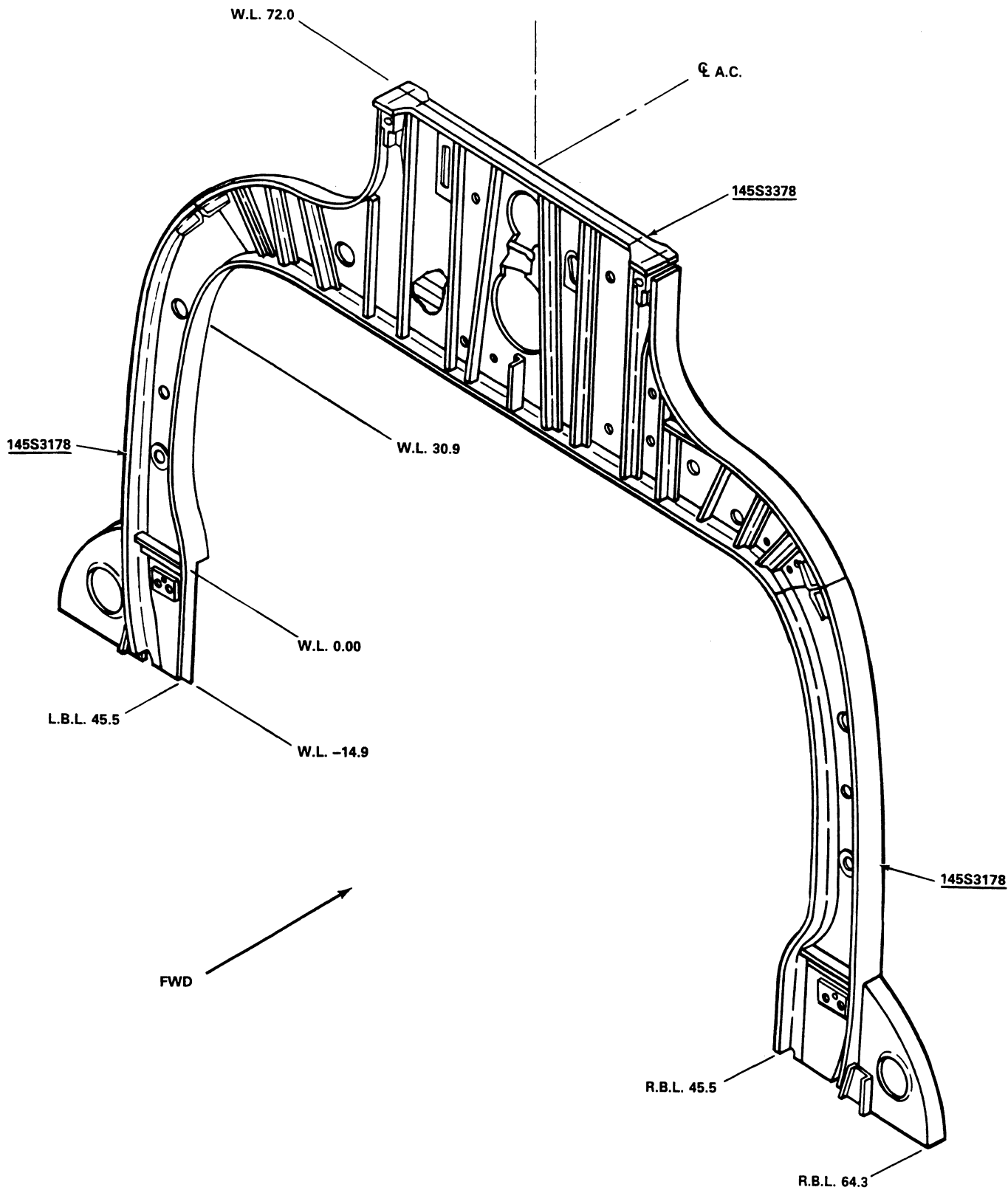

FIGURE 29. FORMER STATION 534

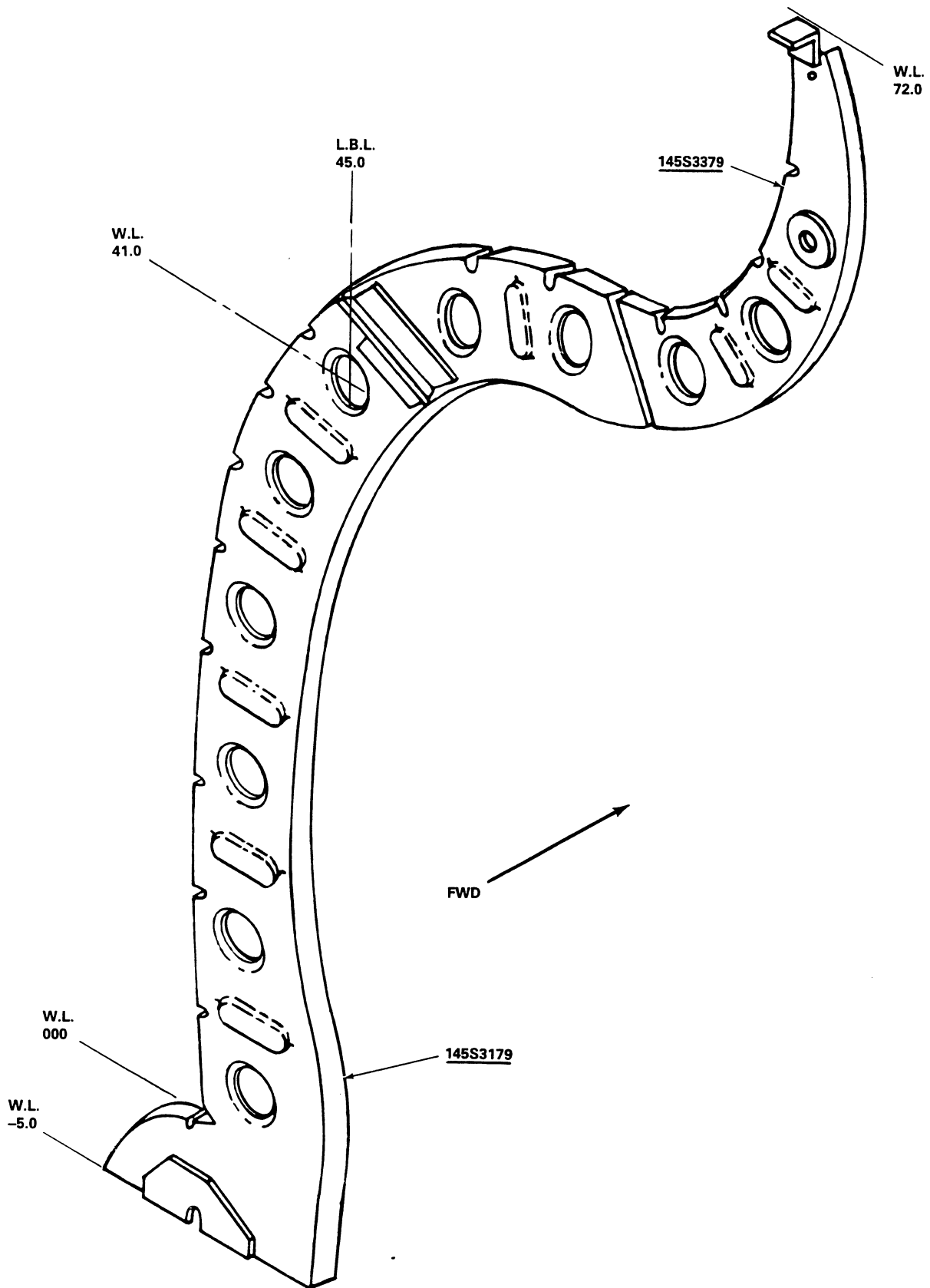

FIGURE 30. FORMER STATION 555

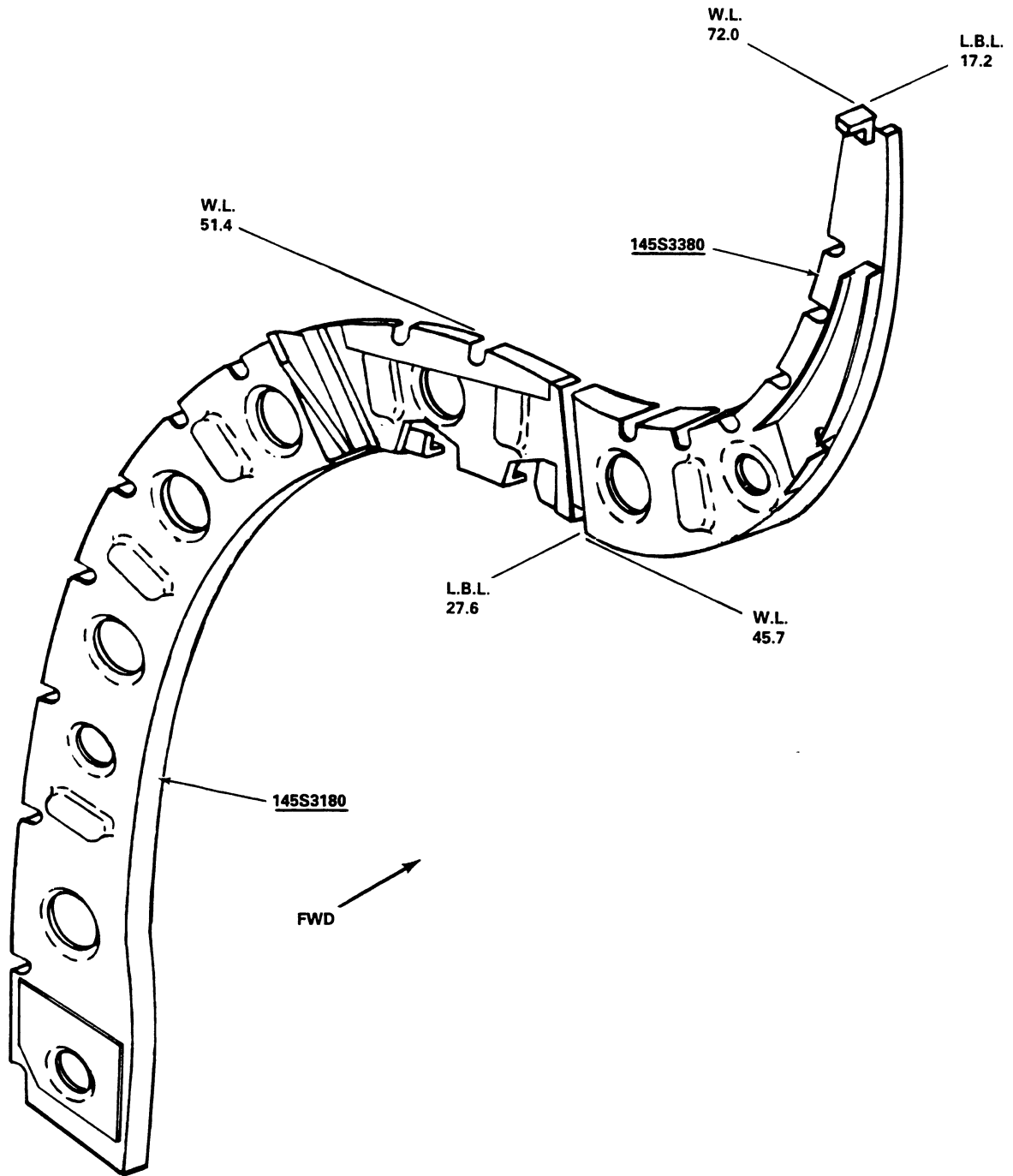

FIGURE 31. FORMER STATION 575

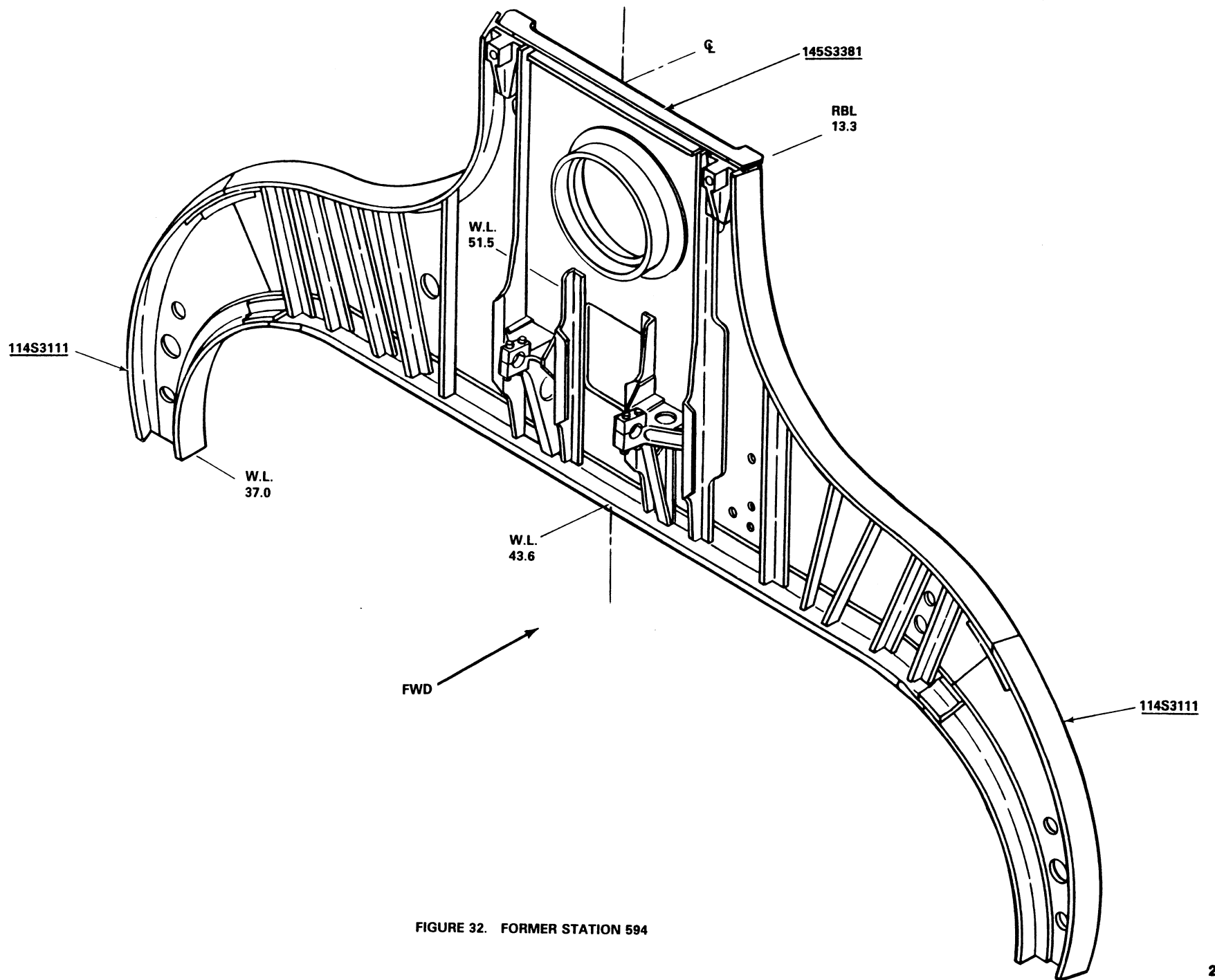

FIGURE 32. FORMER STATION 594