

AD 750150

Boeing Technical Report D210-10506-1
October 1972

Aerial Artillery Design Study
Two Externally Mounted XM204 Howitzers
on a CH-47C Helicopter

Prepared for

Advanced Concepts Division
Aircraft Weapons Systems Directorate
Weapons Laboratory, WECOM
Rock Island, Illinois

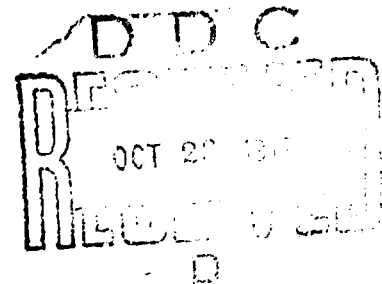

Contract DAAF03-72-C-0016
The Boeing Company, Vertol Division
Philadelphia, Pennsylvania

Reproduced by
NATIONAL TECHNICAL
INFORMATION SERVICE
U.S. Department of Commerce
Springfield, VA 22151

Distribution of this document is unlimited.

DISTRIBUTION STATEMENT A
Approved for public release;
Distribution Unlimited

Unclassified

Security Classification

DOCUMENT CONTROL DATA - R & D

(Security classification of title, body of abstract and indexing annotation must be entered when the overall report is classified)

1. ORIGINATING ACTIVITY (Corporate author) The Boeing Company, Vertol Division Philadelphia, Pennsylvania 19142		2a. REPORT SECURITY CLASSIFICATION Unclassified	
		2b. GROUP None	
3. REPORT TITLE Aerial Artillery Design Study Two Externally-Mounted XM 204 Howitzers on a CH-47C Helicopter			
4. DESCRIPTIVE NOTES (Type of report and inclusive dates) Twelve Part Final Report			
5. AUTHOR(S) (First name, middle initial, last name) Alfred Bonnell-Design; Steve S.S. Dallas-Performance; Robert P. Giantonio-Vibration/Dynamics; Leo Gumienny-Integration; Edward H. Higgins- Stress Analysis; Norman I. Klavens-Muzzle Blast; Arthur MacArthur-Missions; Albert B. Meyer-Aeroelasticity; Henry J. Neeb-Flying Qualities; English Piper-Fire Control; Richard R. Pruyn-Summary; Richard D. Semple-Propulsion; Maurice E. Snook-Weights.			
6. REPORT DATE October 1972		7a. TOTAL NO. OF PAGES xxvi + 224	7b. NO. OF REFS 25
8a. CONTRACT OR GRANT NO. DAAF03-72-C-0016		9a. ORIGINATOR'S REPORT NUMBER(S) D210-10506-1	
b. PROJECT NO.		9b. OTHER REPORT NO(S) (Any other numbers that may be assigned this report) None	
c.			
d.			
10. DISTRIBUTION STATEMENT Distribution of this document is unlimited.			
11. SUPPLEMENTARY NOTES None		12. SPONSORING MILITARY ACTIVITY United States Army Weapons Command Rock Island, Ill. 61201	
13. ABSTRACT Design arrangement and mounting approaches, weight estimates, balance calculations, stress analyses, and helicopter performance predictions of an aerial artillery system utilizing two externally-mounted 105mm XM204 soft recoil howitzers on a CH-47C Chinook helicopter are presented. This design provides for all the firing modes and operational capabilities required by the Weapons Command, including the ability to offload one howitzer when the helicopter is hovering. The study includes an analysis of the structural integration of the weapons and aircraft including muzzle blast effects and airframe dynamic responses. A minimum adequate fire control system for air-to-ground firing and typical ground artillery fire control equipment was included. Mission capabilities of this system include delivery of 60 rounds of rapid air-to-ground firing at the midpoint of a 100-nautical-mile radius with 15 minutes loiter to acquire the target. Delivery of a howitzer for detached firing and a mission using the aerial artillery for attached firing were also considered. Model testing that demonstrated the feasibility of modeling the 105mm howitzer for muzzle blast effects was also included.			

DD FORM 1473
1 NOV 65

Unclassified

Security Classification

i-A

Unclassified

Security Classification

KEY WORDS	LINK A		LINK B		LINK C	
	ROLE	WT	ROLE	WT	ROLE	WT
Aerial Artillery						
XM204 Howitzer						
CH-47C Chinook Helicopter						
Fire Control						
Muzzle Blast and Flash						
Soft Recoil						
Attack Helicopter						
Airborne 105mm Howitzer						
Model Blast Testing						

Unclassified

Security Classification

1-6

Contract DAAF03-72-C-0016
Boeing Technical Report D210-10506-1
October 1972

AERIAL ARTILLERY DESIGN STUDY
TWO EXTERNALLY MOUNTED XM204 HOWITZERS
ON A CH-47C HELICOPTER

FINAL REPORT

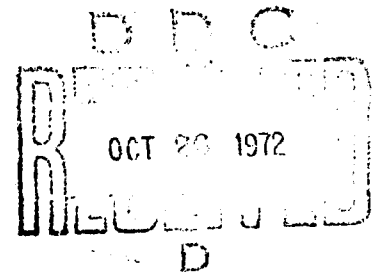

Prepared by
The Boeing Company, Vertol Division
Philadelphia, Pennsylvania 19142

For
Advanced Concepts Division
Aircraft Weapons Systems Directorate
Weapons Laboratory, WECOM
Rock Island, Illinois 61201

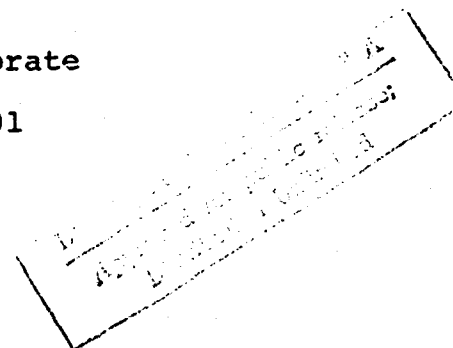

i-c

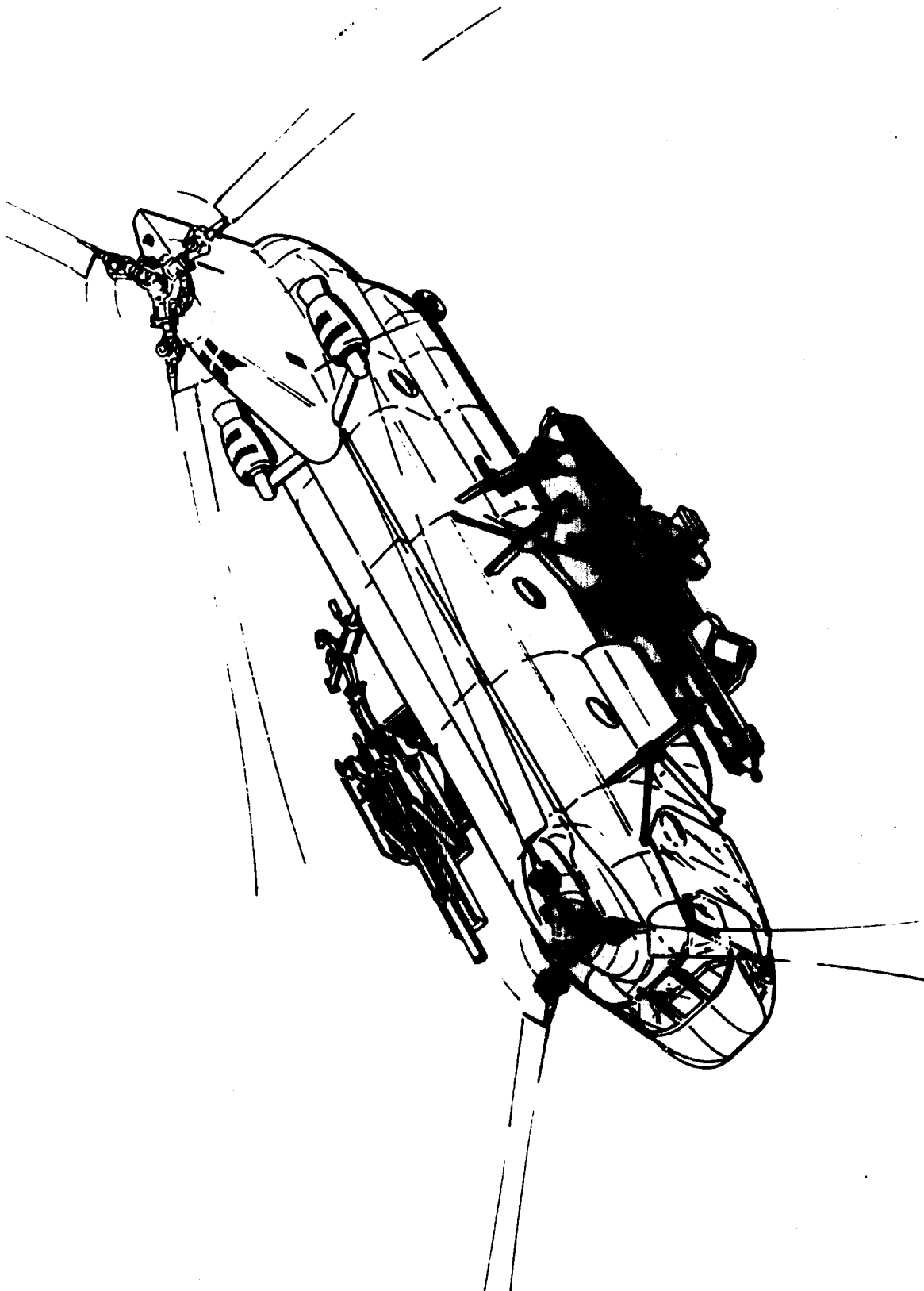

Figure 1. CH-47C Helicopter Aerial Artillery Weapon System

SUMMARY

A comprehensive preliminary design study has been conducted to further define the physical and functional compatibility in selected areas for the integration of the XM204 howitzer and impulse generator system with the CH-47C helicopter for both air-to-ground and ground-to-ground firing. Findings of this study can be summarized as follows:

1. Performance: Missions of about a 100-nautical-mile-radius can be accomplished carrying 96 rounds and a 9-man gun crew. Running takeoffs will be required for atmospheric conditions more severe than sea level standard conditions.
2. Structural Integrity: Reinforcement of the helicopter for muzzle blast protection and to provide hardpoints for the howitzer installation will increase the empty weight of the CH-47C helicopter by 256 pounds. Rotor system stresses due to airborne and ground firing will not reduce the service life of these components. Stresses due to prolonged operation at high gross weights may reduce the service life of forward rotor components.
3. Vibration: Response of the howitzers to the vibratory environment of the CH-47C can reduce the vibration of the helicopter at the penalty of +1,500-pound vibratory loads in the mounting structure. Detail design of the installation needs to tune the structure or provide for vibration isolation.
4. Responses to Firing: Helicopter motions and elastic responses to recoil and muzzle blast of the soft-recoil XM204 howitzer firing at charge zones up to zone 8 are well within the capabilities of the control system, the structure, and the crew. There does not appear to be any need for the zero-recoil-producing impulse generator rocket system for the CH-47C installation.
5. Weight and Balance: The design presented has horizontal and lateral center of gravity travels that are well within the limitations of the CH-47C.

The final design configuration, illustrated in Figure 1, includes two howitzers mounted externally on the helicopter. These howitzers point forward in the traveling position and also for air-to-ground firing. The left-side howitzer installation includes hoists for rapid removal for detached firing. The right-side howitzer is mounted on a small firing platform so that ground-to-ground attached firing can be provided as soon as the helicopter lands without subsequent moving of the

weapon or other time-consuming tasks. A rotor brake is included in the design to provide more rapid response in the ground-to-ground attached mode. The design of the installation provides a hardpoints provisions kit that involves minimum modification and only a 256-pound increase in the empty weight of the helicopter. Subsequent installation or removal of the howitzer weapons kit onto the hardpoints-provisioned helicopter within one hour with a 10-man crew appears to be feasible. About 50 bolts are involved in the attachment of the weapons kit. Helicopter performance calculations show that the weapons installation penalizes the lifting and cruise capabilities, but missions of a 100-nautical-mile radius with 96 rounds and a full gun crew can be achieved with the CH-47C helicopter.

Provisions for the impulse generator system have been considered in the design, but the supporting technology efforts have shown that this system is not required. Analyses of helicopter motions and elastic deflections caused by the recoil due to inflight firing of the soft-recoil XM204 at zone 5 without the impulse generators show that these responses are negligibly small. Since the impulse generator system requires doubling the automatic loading complication and would increase the system weight by about 200 pounds, this system has not been included in the final design drawings.

The howitzer for ground-to-ground attached firing that is mounted on the right side of the helicopter consists of an XM204 modified to have the grouser wheels replaced by a gear pinion drive. The small external firing platform shown in Figure 2 is provided for crew operation of the weapon in the ground-to-ground attached firing mode. Muzzle blast reinforcements are not provided in the aft portion of the helicopter, so firing is limited to an azimuth sector of 150 degrees. Addition of a rotor brake to the helicopter and provision for quick removal of the air-to-ground ammunition feed system are provided to allow for firing of the first round of ground-to-ground attached fire within one minute after the helicopter lands. Of course, it would take a well-trained and well-motivated crew to execute all the tasks involved within this brief time. The most time-consuming task in firing this first round appears to be the setup of conventional artillery fire control aiming stake. A screwjack firing base is provided to prevent gun-jump in this attached-firing mode.

The howitzer on the left side of the helicopter is a complete XM204 field piece with attachment fittings added for mounting on the two retractable gun support beams. Two cables and winches are attached to the howitzer to lift the weapon clear of the remotely actuated attachment clamps on the gun support beams. When the howitzer has been lifted, the beams can be retracted to clear the way for lowering the howitzer to the ground. Present studies indicate that it is not necessary,

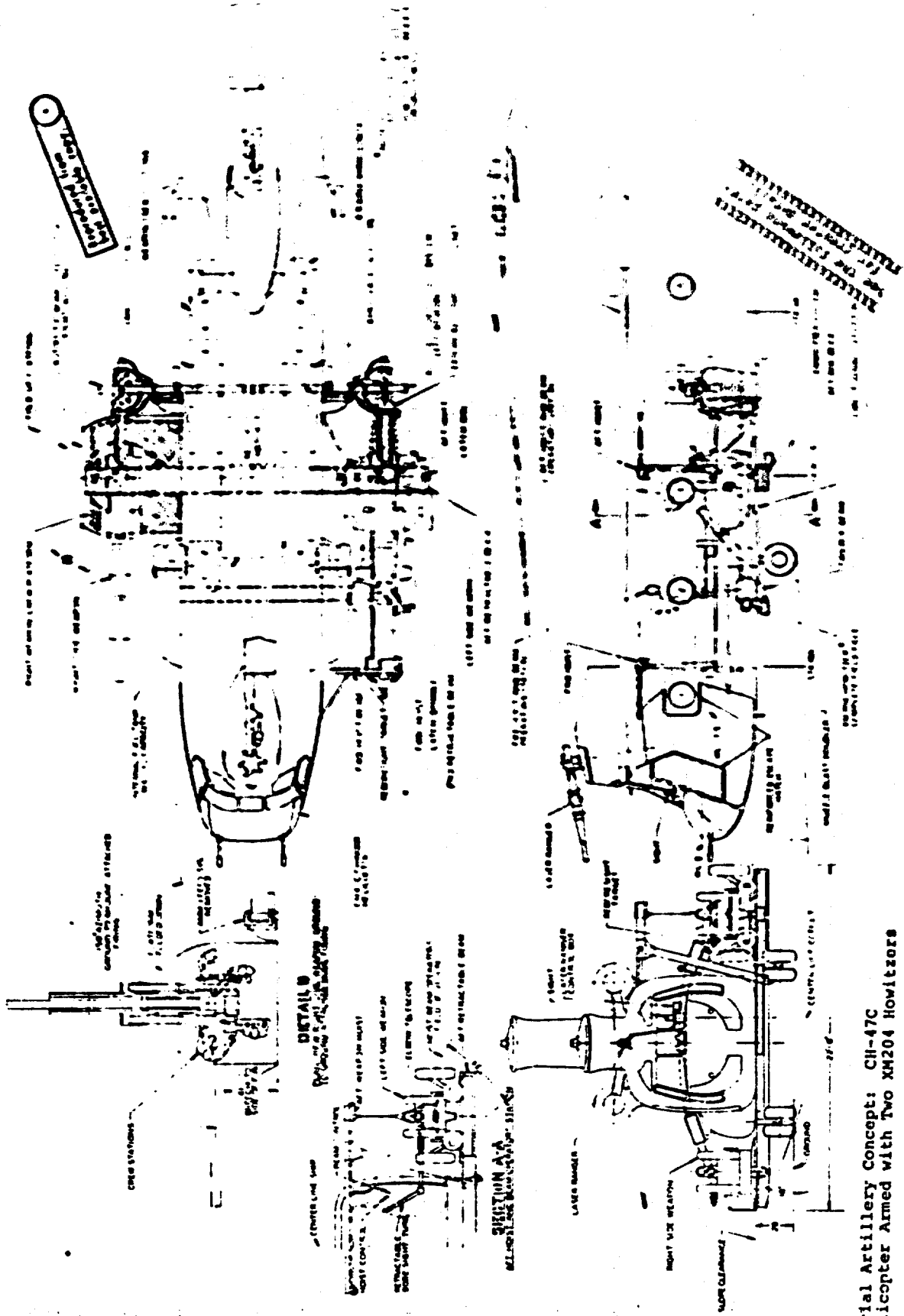

Figure 2. Aerial Artillery Concept: CH-47C Helicopter Armed with Two XM204 Howitzers

A

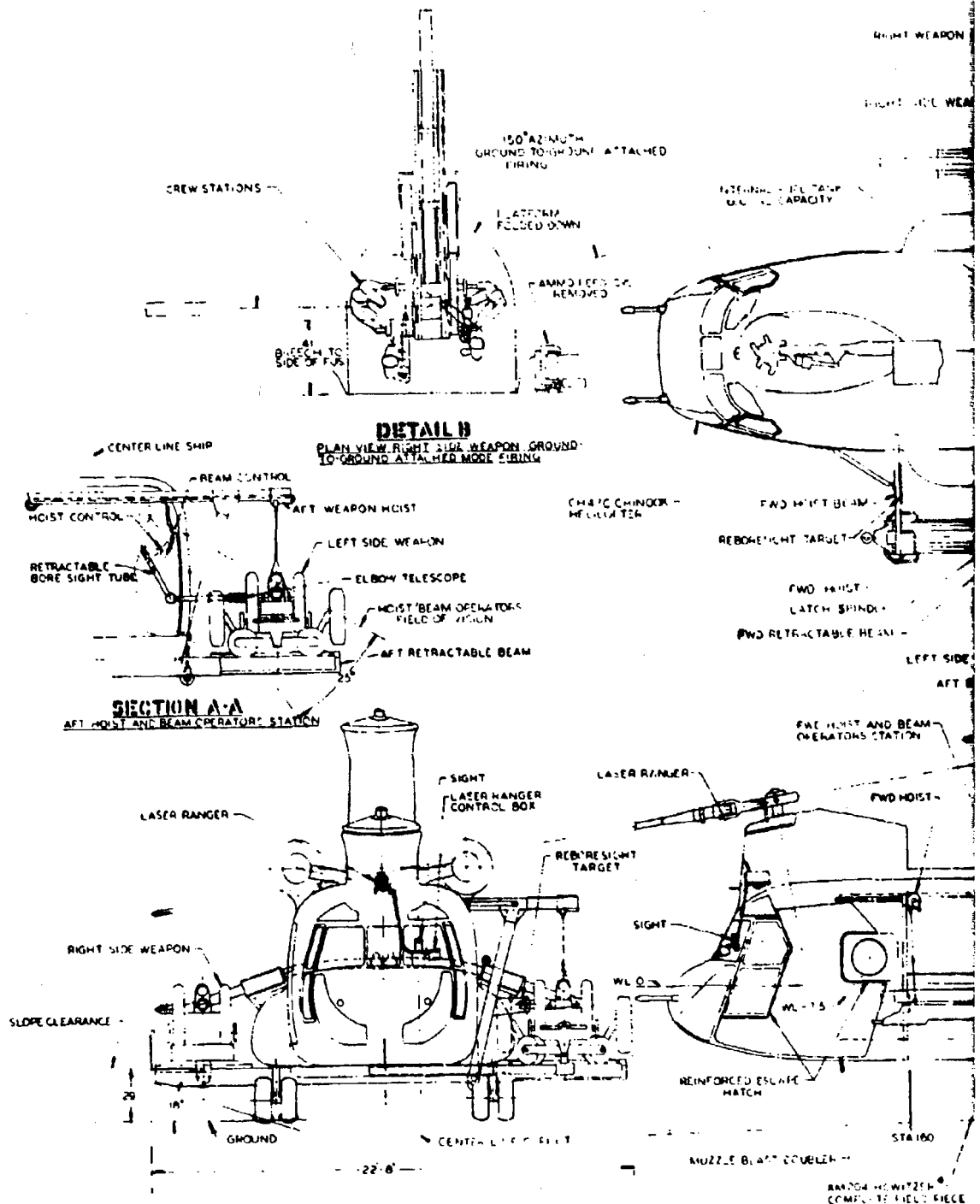
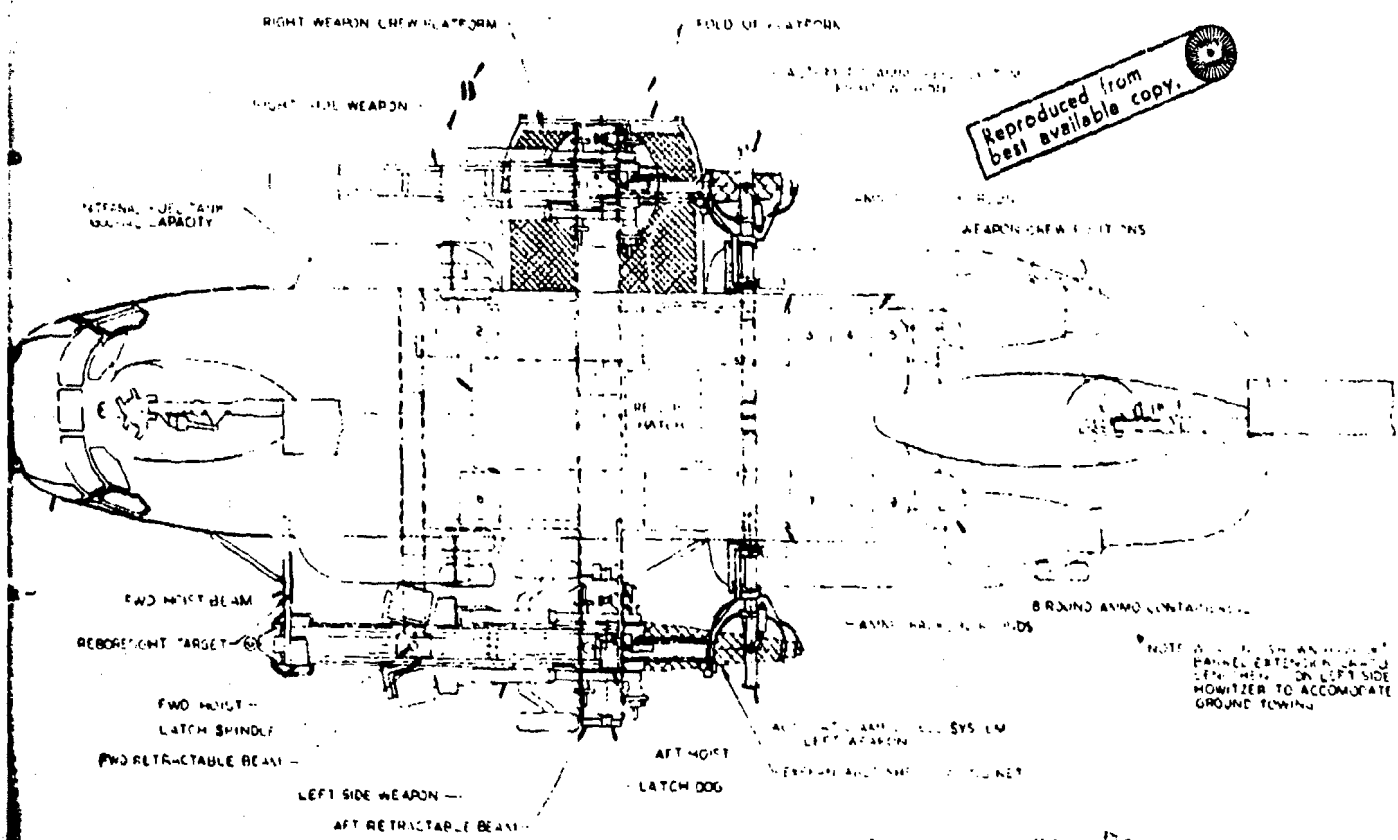

Figure 2. Aerial Artillery Concept: CH-47C Helicopter Armed with Two XM204 Howitzers

V

1.1

12



Reproduced from best available copy.

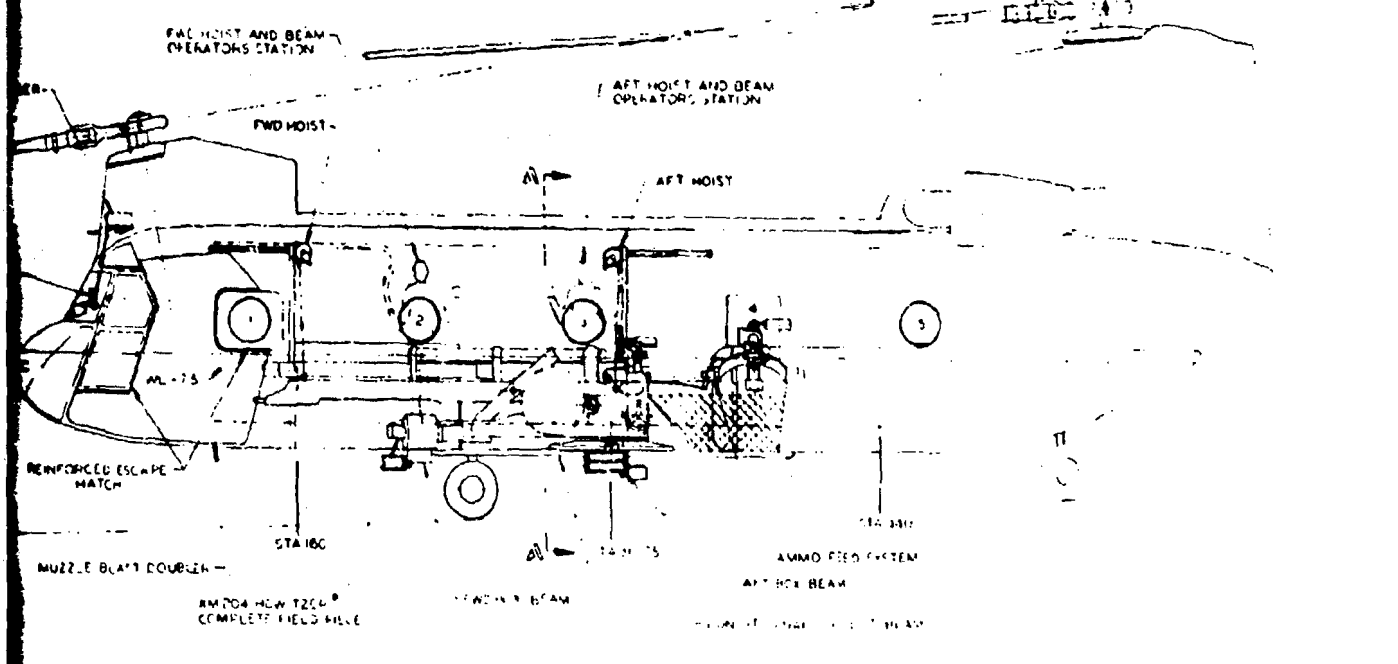

11

but it is possible to lower the howitzer to the ground from the center of gravity of the helicopter if an additional sling is provided. The cables would lower the howitzer down to the sling and then the sling would be used to position the weapon on the ground.

As shown in Figure 2, both XM204 soft-recoil howitzers are mounted for forward direct air-to-ground firing with automatic ammunition-loading mechanisms provided for rapid firing (30 rounds per minute each). The copilot is provided with a simple, fixed, depressible-reticle sight and laser rangefinder for aiming the helicopter/gun system for firing in this mode. Preflight adjustments of the howitzer elevation settings will allow for aiming the weapons with the helicopter at various airspeeds, rates of climb, and heights above the target.

The hardpoints kit required for installation of the weapons kit is illustrated in Figure 3. This hardpoints kit will add 256 pounds to the empty weight of the helicopter, but in no other way will it reduce the operational utility of the aircraft. Most of the added weight is due to the reinforcement of both sides of the front of the helicopter provided for muzzle blast protection in air-to-ground direct firing. This reinforcement was sized for unintentional firing of a zone 8 round and includes external skin doublers and increased-thickness transparent areas. The only other external members are the reinforced openings with appropriate closures for the winch top beams. Internal reinforcements for the weapon support beam attachment include four frame-reinforcement bathtub fittings between the frames at stations 200, 240, 280, and 320. Also provided internally are frame web doublers at each of the above frames and for the frame at station 160. A new hydraulic pump and valve, as well as some added electrical connections, are required. This hardpoints provisions kit is envisioned as being installed into many designated helicopters in the combat zone during accomplishment of other field maintenance.

The design described herein has been studied in adequate detail to size the major components and fittings so that the installation weight could be estimated to within 100 pounds. This analytical substantiation included calculation of stresses, vibration dynamics, helicopter dynamic motions and elastic response due to recoil loads, and muzzle blast structural loads. Rotor blade dynamic response, weight and balance, and helicopter performance were also calculated. Results of these analyses are reflected in the design and are presented in detail.

Component weights of the design installation on the CH-47C helicopter are summarized in Table I. As shown in this table, there is allowance for 96 rounds of ammunition with no crate or packing weight since the rounds are stored in the fixed

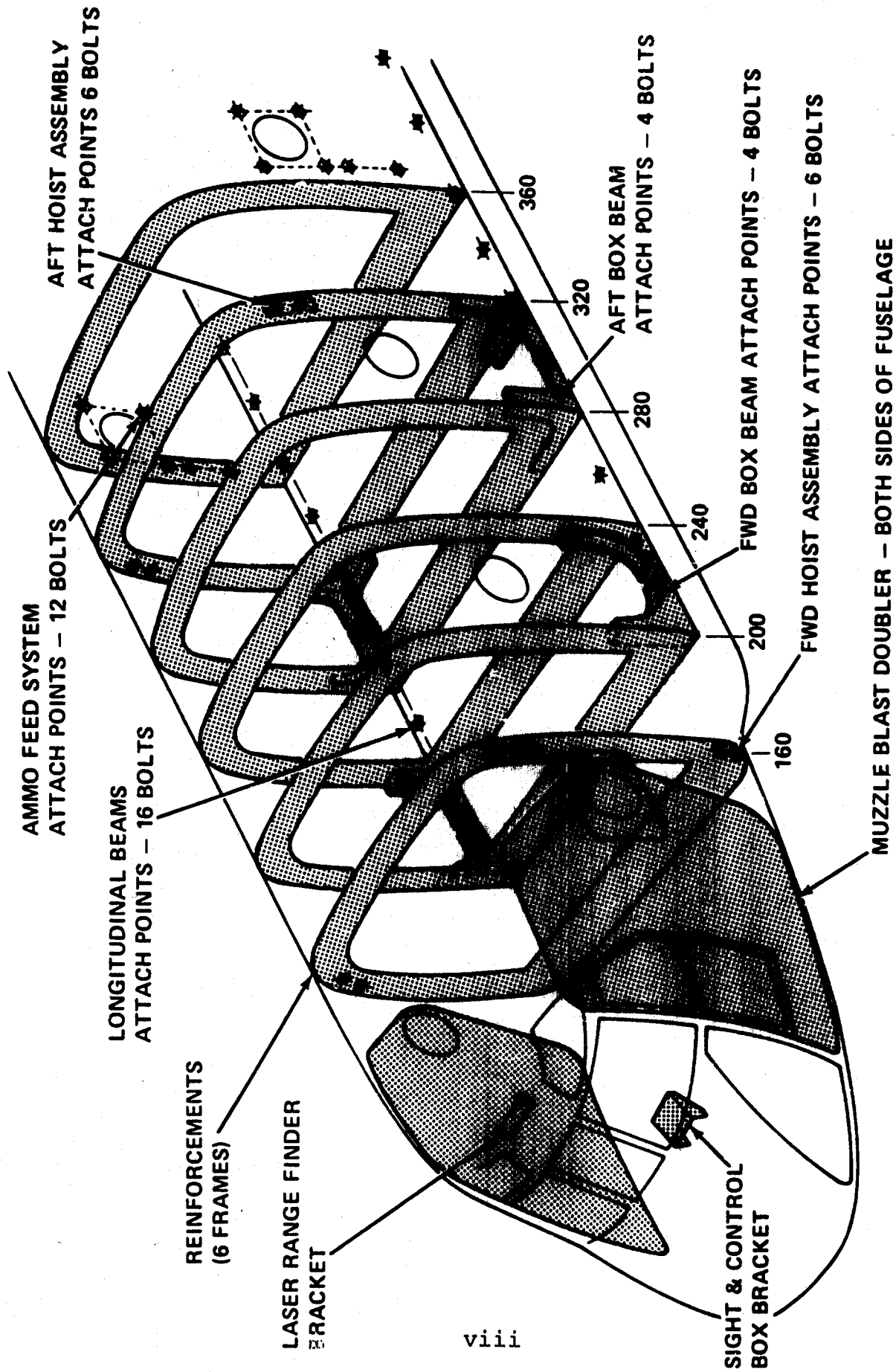

Figure 3. Hardpoints Provisions and Fastener Attach Points for Weapons Kit Installation

TABLE I. HELICOPTER AND KIT WEIGHT SUMMARY

Item	Weight (lb)
Helicopter Empty Weight	20,743
Remove Troop Provisions	-93
Fuel Tank Changes	151
Combat Equipment (Armor, Suppressive Fire Weapons)	0
Hardpoints Provisions Kit	256
Weapons Kit (Including 6,951 lb of Howitzers)	10,690
Full Fuel	7,004
Ammunition (96 rounds)	3,820
Gun Crew (9 Men)	1,800
Fixed Useful Load (Aircrew, etc.)	<u>689</u>
Total	45,060
Alternate Design Gross Weight	46,000

racks and the readily removable containers. The 7,004 pounds of fuel provided will allow the CH-47C to exceed the 100-nautical-mile design radius missions. As shown in the table, no weight allowance is made for combat equipment which is 2,042 pounds (assuming that a gun crew member could fire one suppressive-fire weapon) for SEA operations of the CH-47C. If this combat equipment is required, the mission radius capability would be reduced to about 60 nautical miles. Further growth of the helicopter during the timeframe of the development of the weapon installation is likely to cause significant increases in this capability.

MODEL GUN TESTING

This study also included testing in which the feasibility of modeling the 105mm howitzer at the 1/11 scale appropriate for subsequent helicopter model testing was successfully demonstrated. Scaled muzzle blast fields were generated which were within 0.5 psi of the full-scale predictions. Response of scaled airframe panels was also explored. Testing of a model CH-47C helicopter with muzzle blast caused by a model howitzer is recommended to further substantiate the rotor blade loads and dynamic response analyses.

FOREWORD

This report describes the results of a preliminary design study conducted to show how the XM204 howitzer could be integrated with the CH-47C helicopter in such a way as to provide for various firing modes required by the U. S. Army. This study was conducted under Contract DAAF03-72-C-0016 during the period from December 1971 to October 1972. Technical cognizance for this project at Weapons Command, Rock Island Arsenal, was initially provided by Lawrence L. Frauen; and in the final stage of the study, this cognizance passed to Thomas J. Redling. Both these men were of the Aircraft Weapons Systems Directorate, Advance Concepts Group, under the supervision of John A. Reynolds. William G. Smith, Chief of the Future Weapons Division of the Research, Development and Engineering Directorate, also provided impetus and guidance to this effort. The authors also wish to acknowledge the help of Mark J. Salsbury, Artillery Weapons Systems Directorate, Rock Island Arsenal, William P. Burgess and Dr. Glen Moore of the Naval Weapons Laboratories, Dahlgren, Virginia, and Robert G. S. Sewell of the Naval Weapons Center, China Lake, California, for their significant contributions to the muzzle blast work performed. The authors of this report and the areas of the principle contribution are:

Alfred Bonnell	- Design
Steve S. Dallas	- Performance
Robert P. Giantonio	- Vibration/Dynamics
Leo Gumienny	- Integration
Edward H. Higgins	- Stress Analysis
Norman I. Klavens	- Muzzle Blast
Arthur MacArthur	- Missions
Alfred B. Meyer	- Aeroelasticity
Henry J. Neeb	- Flying Qualities
English Piper	- Fire Control
Richard R. Pruyn	- Summary
Richard D. Semple	- Propulsion
Maurice E. Snook	- Weights

TABLE OF CONTENTS

	<u>Page</u>
SUMMARY	iii
FOREWORD	xi
TABLE OF CONTENTS	xiii
LIST OF ILLUSTRATIONS	xvi
LIST OF TABLES	xxi
LIST OF SYMBOLS	xxiii
INTRODUCTION	1
DEFINITION OF THE DESIGN MISSIONS	5
Ground-to-Ground Attached Firing Mission	5
Ground-to-Ground Detached Firing Mission (Land to Detach)	7
Ground-to-Ground Detached Firing Mission (Hovering Detachment)	7
Air-to-Ground Firing Mission	7
DESIGN PHILOSOPHY	11
WECOM Conceptual Requirements	11
Additional Boeing Conceptual Requirements	13
DESCRIPTION OF THE CONFIGURATION AND FUNCTION OF COMPONENTS	15
Weapons Kit and Hardpoints Provisions	21
Installation Procedure for Weapons Kit	24
Automatic Ammunition Feed System	25
STRUCTURAL COMPONENT SIZING CONSIDERATIONS	27
Malfunction and Crash Load Paths	27
Load Paths for Normal Operations	28
Weapon and Helicopter Vibration Prediction	30
Component Vibration Testing	40
Hanging Shake Test	41
MUZZLE BLAST AND FLASH EFFECTS	42
Reinforcement of Fuselage Skin	42
Structural Reinforcement	45
Plexiglas Reinforcement	45
Rotor Blade Loads, Stresses, and Responses	47

	<u>Page</u>
DYNAMIC RESPONSES OF AIRCRAFT TO WEAPON FIRING	59
Dynamic Responses to Muzzle Blast	59
Aircraft Response to Recoil Loads	61
Elastic Response of Fuselage to Recoil Loads	62
Sustained Fire Effects	62
EFFECTS OF GUN GAS INGESTION AND MUZZLE BLAST ON ENGINES	70
Air-to-Ground Firing	70
Ground Firing	71
WEIGHT, BALANCE, AND CONTROL	72
Design Mission Loadings	72
Lateral Control, Hover Offloading of Left Weapon	81
FLIGHT PERFORMANCE	83
Configuration	83
Hover Performance	84
Takeoff Performance	84
Performance Basis	93
FIRE CONTROL	106
Ground-to-Ground Firing Mode	106
Air-to-Ground Firing Mode	106
CONCLUSIONS	112
RECOMMENDATIONS	114
REFERENCES	115
APPENDIXES:	
I. Helicopter and Weapon Parameters	118
II. Design Criteria and Loads	133
III. Requirements for the Structural Test Program	142
IV. Stress Analysis	144
V. Detail Weight Substantiation	177

	<u>Page</u>
VI. Test Firing of Model Howitzer to Produce Muzzle Blast Fields	180
VII. Testing of Model Structural Panel with Model Howitzer to Explore Dynamic Effects of Muzzle Blast	209
VIII. Performance Substantiation	216
DISTRIBUTION	223

	<u>Page</u>
VI. Test Firing of Model Howitzer to Produce Muzzle Blast Fields	180
VII. Testing of Model Structural Panel with Model Howitzer to Explore Dynamic Effects of Muzzle Blast	209
VIII. Performance Substantiation	216
DISTRIBUTION	223

LIST OF ILLUSTRATIONS

<u>Figure</u>		<u>Page</u>
1	CH-47C Helicopter Aerial Artillery Weapon System	ii
2	Aerial Artillery Concept: CH-47C Helicopter Armed with Two XM204 Howitzers	v
3	Hardpoints Provisions and Fastener Attach Points for Weapons Kit Installation	viii
4	Mission 2, Aerial Artillery Ground-to-Ground Firing Mode (Howitzer Attached)	6
5	Mission 3, Aerial Artillery Ground-to-Ground Firing Mode (Howitzer Detached Hover Unloading)	8
6	Mission 1, Aerial Artillery Air-to-Ground Firing Mode	10
7	Left Weapon On-Loading During Hover Sequence	18
8	Aerial Artillery System Power and Control Schematic	19
9	Pneumatic Ammo Feed System Installation in Number 4 Window	26
10	Aerial Artillery System Weapon Support Structure	29
11	Aerial Artillery Left Weapon Hoist Structure	31
12	CH-47C and CH-47C AAWS 3/Rev Vibration Comparison	32
13	Structural Model System Used for Dynamic Analysis	34
14	Flow Diagram for Airframe Forced Vibration Calculations	35
15	CH-47C AAWS Gun Support Modes	38
16	Critical Mode Comparison, CH-47C and CH-47C AAWS	39
17	Aluminum Doublers and Reinforced Hatches are Required on Both Sides of Nose of Fuselage	43

<u>Figure</u>		<u>Page</u>
18	Fuselage Projection of the Free-Space Overpressures Due to Zone 5 Firing of the Extended-Barrel XM204 Howitzer	44
19	Location of the Most Critical Panel of Fuselage for Muzzle Blast Damage	46
20	CH-47C Spar Ultimate Maneuver Stresses as Affected by Muzzle Blast Pressure	48
21	CH-47C Spar Fatigue Stresses as Affected by Blast Pressure	49
22	Projection of Overpressure Isobar Pattern on Forward Rotor	50
23	Muzzle Blast Pressure Pulse Representation Used in Aeroelastic Rotor Loads Calculations	51
24	Flapwise Bending of Blades Due to Zone 5 Muzzle Blast	53
25	Flapwise Excursion of the Blades is Predominantly Rigid-Body Motion	54
26	Torsional Moment Distribution Due to Blast	56
27	Rotor Control Pitch Link Loads Due to Muzzle Blast	57
28	Blade Tip Twisting Deflection Due to Muzzle Blast	58
29	Single-Degree-of-Freedom Analysis Illustrates Significant Modes of Response	60
30	Responses to Recoil Are Reduced with Increased Airspeed	64
31	Responses to Recoil Increase with Increased Firing Zone	65
32	Helicopter Responses to Recoil Do Not Vary Much With Gross Weight	66
33	CG Variations Have Small Effect on Responses to Recoil	67
34	Small Control Inputs Can Correct the Effects of Recoil	68

<u>Figure</u>		<u>Page</u>
35	Deflection Response of the Cockpit Due to the Recoil Load from a Single Firing of One Weapon	69
36	Weight and Longitudinal Balance are Within Limits for the Design Weapon, Fuel and Ammunition Loading	76
37	Lateral-Longitudinal Center of Gravity Diagram CH-47C Aerial Artillery	80
38	Roll Attitude Limits Versus Airspeed	82
39	CH-47C Helicopter Hover Ceiling Versus Gross Weight	85
40	Capability of Aerial Artillery CH-47C on Detachable Howitzer Mission at Sea Level Standard Conditions	86
41	Capability of Aerial Artillery CH-47C on Air-to-Ground Firing Mission at Sea Level Standard Conditions	87
42	Capability of Aerial Artillery CH-47C on Ground-to-Ground Attached-Firing Mission at Sea Level Standard Conditions	88
43	Capability of Aerial Artillery CH-47C on Detachable Howitzer Mission at 2,000 Feet, 95°F	89
44	Capability of Aerial Artillery CH-47C on Air-to-Ground Firing Mission at 2,000 Feet, 95°F	90
45	Capability of Aerial Artillery CH-47C on Ground-to-Ground Attached-Firing Mission at 2,000 Feet, 95°F	91
46	CH-47C Helicopter Hover Power and Fuel Flow Versus Gross Weight	96
47	CH-47C Helicopter Hover Power and Fuel Flow Versus Gross Weight	97
48	CH-47C Helicopter Standard Configuration Level Flight Power Required	98
49	CH-47C Helicopter Aerial Artillery Configuration Level Flight Power Required	99
50	CH-47C Helicopter Standard Configuration Level Flight Power Required	100

<u>Figure</u>		<u>Page</u>
51	CH-47C Helicopter Aerial Artillery Configuration Level Flight Power Required	101
52	CH-47C Helicopter Specific Range Versus Airspeed	102
53	CH-47C Helicopter Specific Range Versus Airspeed	103
54	CH-47C Helicopter Specific Range and Cruise Speed Versus Gross Weight	104
55	CH-47C Helicopter Specific Range and Cruise Speed Versus Gross Weight	105
56	Geometry Involved in the Air-to-Ground Firing	109
57	Helicopter Attitude Changes with Flight Speed in Level Flight	110
58	Elevation and Delta Height Relationship for Zone 5, M1 Rounds	111
59	CH-47C Three-View	119
60	XM204 Howitzer, Light Towed, 105mm Soft Recoil	127
61	CH-47C Structural and Power Flight Limitations for STD	147
62	Comparison of Predicted and Model Overpressure Measurements for 2.82 Pounds (Zone 7) of Equivalent Full-Scale Charge	181
63	(a) Scale Model Weapon on Ballistic Test Mount (b) Model Ammunition Showing Projectile Modifications	184
64	Setup for Muzzle Velocity Measurement in Boeing-Vertol Test Range	186
65	Comparison of Full-Scale and Model Muzzle Velocity Measurement	187
66	Scope Trace of 14 Grain Firing Test	188
67	Scope Trace of 10.1 Grain Firing Test	188
68	Scope Trace of 17 Grain Firing Test	189

<u>Figure</u>		<u>Page</u>
69	Scope Trace of 7.25 Grain Firing Test	189
70	Comparison of Predicted and Model Overpressure Measurements at 50 Calibers Off Boresight	190
71	Comparison of Predicted and Model Overpressure Measurements at 40 Calibers Off Boresight	191
72	Geometry of Model Projectile	193
73	Test Setup for Measurement of Muzzle Blast	195
74	Test Setup for Transducer Calibration	196
75	Comparison of Predicted and Model Overpressure Measurements at 40 Calibers Off Boresight Using Projectiles With Reduced Engraving	197
76	Comparison of Predicted and Model Overpressure Measurements at 30 Calibers Off Boresight	199
77	Comparison of Predicted and Model Overpressure Measurements at 30 Calibers Off Boresight Using Projectiles With Reduced Engraving	200
78	Comparison of Predicted and Model Overpressure Measurements at 20 Calibers Off Boresight	201
79	Comparison of Predicted and Model Overpressure Measurements at 20 Calibers Off Boresight Using Projectiles With Reduced Engraving	202
80	Comparison of Predicted and Model Overpressure Measurements at 10 Calibers Off Boresight	203
81	Comparison of Predicted and Model Overpressure Measurements for 3.23 Pounds Equivalent Full-Scale Charge	204
82	Comparison of Predicted and Model Overpressure Measurements for 3.8 Pounds of Equivalent Full-Scale Charge	205
83	Scale Model Skin Panel and Supporting Structure	210
84	Scale Model Skin Panel	211
85	Downwash Velocity Distribution Used for Hover Download Calculation	218

LIST OF TABLES

<u>Table</u>		<u>Page</u>
I	Helicopter and Kit Weight Summary	ix
II	Aerial Artillery Documents	3
III	Model CH-47C AAWS and CH-47C Frequency Comparison	37
IV	Weight and Balance of Aircraft Less Weapons, Fuel, Ammunition, and Useful Load	73
V	Weight and Balance for Forward Loadings of Fuel, Ammunition, Etc.	74
VI	Weight and Balance for Aft Loadings	75
VII	Balance Calculations for Lateral Loadings	77
VIII	Summary, Lateral Trim Changes with Weapon Offloading	79
IX	Comparison of Aerial Artillery Configuration to Standard Configuration	83
X	Mission Performance Summary	92
XI	Engine Characteristics and Weight and Performance Criteria	132
XII	Design Recoil Limit Loads Criteria	135
XIII	Distribution of Ground Firing Conditions to be Used for Right-Side Howitzer	136
XIV	Design Limit Loads	138
XV	Critical Design Limit and Ultimate Loads	139
XVI	Ultimate Design Load Summary	140
XVII	Basic CH-47C Fatigue Loading Schedule	145
XVIII	CH-47C AAWS Fatigue Loading Schedule	146
XIX	Reduced Forward Rotor Component Lives Due to Continuous High Gross Weight Operations of Aerial Artillery Missions	149
XX	Replica Model (Hopkinson) Scaling Laws	182

Table

Page

XXI Model Versus Full-Scale Weapon Parameters

182

LIST OF SYMBOLS

MUZZLE BLAST

b	width of skin panel, inches
c	bore diameter (caliber), inches
C	velocity of sound in aluminum, ft./sec.
E	modulus of elasticity, psi
E_A	total energy available in propellant, ft.lb.
E_p	kinetic energy of projectile, ft.lb.
E_T	thermal energy, ft.lb.
f_0	natural frequency, Hz
F_{tu}	ultimate yield strength of a material, psi
F_{ty}	static yield strength of a material, psi
H_c	heat of explosion of propellant, calories/gram
I_c	critical impulse, psi-sec.
K	dimensionless constant
L	barrel length, in.
M_p	mass of projectile, slugs
T	period of oscillation (reciprocal of natural frequency), sec.
t_c	critical time, sec.
V_0	muzzle velocity, ft./sec.
W_c	weight of propellant, lb.
X/C	distance in calibers, measured perpendicular to the barrel axis
Z/C	distance in calibers, measured from the muzzle along the barrel axis
λ	geometric length ratio

MUZZLE BLAST (Continued)

Δp	overpressure (absolute pressure minus atmospheric pressure)
σ_y	dynamic yield strength of a material, psi
δ	thickness of skin panel, inches
ϵ	strain

PERFORMANCE

A	total rotor disc area ($2 \pi R^2$), ft ²
A_F	projected frontal area in cruise flight, ft ²
A_V	exposed vertical drag area, sq. ft.
C_D	drag coefficient of aircraft components based on frontal area
C_{D_V}	vertical drag coefficient of fuselage section
DL	download caused in hover by downwash of the rotors impinging on the fuselage and weapon installation, lb.
f_e	equivalent parasite drag area of the airframe and weapon installation or components thereof, ft ²
OGE	out-of-ground effect
R	rotor radius, ft.
T	thrust of the rotors in hover to balance the weight and download of the helicopter, lb.
ρ	mass density of air, slug/ft ³
v	actual downwash velocity, ft/sec.
v_{IND}	induced velocity from momentum theory ($\sqrt{T/2A\rho}$), ft/sec.
κ	factor that accounts for the radial variation of the downwash

PERFORMANCE (Continued)

- Δl length of an increment of the fuselage expressed as a percent of the rotor radius
- \bar{w} width of an increment of the fuselage expressed as a percent of the rotor radius

STRESS ANALYSIS

- E modulus of elasticity in tension, psi
- f calculated stress, psi
- F_{bu} ultimate bearing stress, psi
- F_{by} yield bearing stress, psi
- F_{cu} ultimate compressive stress, psi
- F_{su} ultimate stress in pure shear, psi
- F_{tu} ultimate tensile allowable stress, psi
- F_{ty} tensile yield allowable stress, psi
- G modulus of rigidity
- GW gross weight, lb.
- H_D density altitude, ft.
- H_z weight load components, lb.
- I moment of inertia of section, in⁴
- M applied moments along axis and at point noted in subscript, in.lb.
- MS margin of safety
- $\bar{m}-3\sigma$ mean value less 3 standard deviations of the scatter in the data
- ω rotor speed, rpm
- \bar{w} applied loads in direction and at point noted in subscript, lb.

STRESS ANALYSIS (Continued)

Q	static moment of crosssection, in.lb.
R	stress ratio
t	thickness, in.
V_H	maximum airspeed attainable within the limits of V_{ne} and military rated power, knots
V_{ne}	structural limit airspeed of the helicopter, knots
Z	section modulus, in ³
σ_{cu}	critical ultimate stress, psi
σ	stress, psi
ΔM	moment at the rotor blade to spar attachment per inch of blade span due to muzzle blast
ΔP_{BLAST}	muzzle blast overpressure at the rotor blade, psi
σ_{BLAST}	stress in the blade due to muzzle blast, psi
ρ	radius of gyration, in.
η	maneuver load factor

INTRODUCTION

The helicopter has provided combat units of the Army with increased tactical mobility. This in turn has developed a continuing desire to provide field artillery with matching combat support mobility. This desire has led to the development of aerial rocket artillery that has been deployed with some success. Due to the greater range and accuracy, the reduced cost of rounds, and the greater variety of rounds provided by the field artillery howitzers, there has been a continuing desire to provide more mobility for the howitzers. In fact, development of the CH-47C Chinook helicopter received increased impetus from the need to carry the 155mm howitzer. Sling-load techniques have been developed to rapidly emplace these 13,500-pound weapons. A major problem of sling-loading has been that it degrades the stability of the helicopter, and this has resulted in limited adverse weather capability. While increased stability sling-load systems are being developed, there is a need for a better system. Also, the ability to fire from the air without emplacing the weapon is desired so that the security of the ground situation does not limit firing operations and firing is more responsive and not interrupted when the weapons are being displaced. For these reasons, the Army has continued a low level of effort to develop aerial artillery using howitzers despite serious concerns about the effects of muzzle blast and recoil on the helicopter. This effort is now ready to pay off since the technology of weapons and helicopters has now developed adequately. As shown in this report, the Army's XM204 soft recoil howitzer has reduced the recoil problem to negligible proportions, and the CH-47C helicopter is more rugged and has adequate payload to carry the weapons, ammunition, and additional reinforcements required to take the muzzle blast and other loadings. Previous Army testing of large weapons on the earlier H-21 helicopter showed that this helicopter needed significant reinforcements. Muzzle blast and recoil damage occurred in the large recoilless rifle tests at Aberdeen, results analyzed in Reference 1, and tests of the 75mm Pack howitzer and the 105mm howitzer at Rock Island, References 2 and 3, respectively. This testing experience has been incorporated into the present design and this new design is now ready to be built and tested.

For additional background on the subject of aerial artillery, the years of work on this subject have produced six documents on design study efforts. These reports have been analyzed for content and the matrix of Table II was generated to display areas of significant effort. As shown in the table, various weapons, various helicopter configurations, and tactical effectiveness have been studied. Some supporting technology efforts have been made, but none of these efforts has been to the depth presented in the present report.

The objective of this study was to perform an analysis and study of aerial artillery work items selected from Section G of the U. S. Army Weapons Command document, dated November 1970, entitled, "Aerial Artillery Weapon (Externally-Mounted Concept) (U)." This study has further defined the physical and functional compatibility in selected areas for the integration of the XM204 howitzer and impulse generator system with the CH-47C for selected firing modes.

TABLE II. AIRIAL ARTILLERY SYSTEMS - Continued

Title	Weapon Installation		Stress and Dynamics	Flight Control	Elast	Navigation & Communications	Performance	Fire Control Systems & Surveys	Target Acquisition	Survivability	Mission Effectiveness		
	Weapon Systems	Mounting Configuration									Cost Effectiveness	Tactical Effectiveness	
Aerial Artillery Study Subtask 1.8 Analysis of Ammunition and Fuel Requirements, Contract DAJ001-69-C-1916, July 1963	Howitzers, Rockets, Missiles	Attached & Detached Firing Modes Studied for Various Helicopters					Brief Downwash Effects & Helicopter Performance Reviews				Operational Performance	Effects of Also Extended: Damage and Disasters upon Fuel Requirements and Aircraft Productivity	
Airmobile VTOL Artillery Weapons Systems, May 1963, Boeing Report R-447	Howitzers, Missiles	Attached & Detached Firing Modes Studied for Various Helicopters	Brief Study of Recoil Loads	Review of Flight Control Degradation Related to the Various Bell - helicopters									
Feasibility & Design Study of Airmobile Artillery, Contract W44-177-AMC-108(T), April 1964	Howitzers, Rockets, Missiles	Comprehensive Group of Bell - helicopters, General Arrangement	Brief Study of Recoil Loads	Brief In-Flight Stick Motion Analysis and Communication System Review	Brief Blast Overpressure Analysis	Brief Blast Navigation & Communications System Review	Helicopter Performance Chart Completed: Brief Dynamics Study	Fire Direction System Applicable Survey Reviews	Review of Review of Contaminants and Target of Survival Ability		Cost Effectiveness Comparison of Candidates of Cannon, Late Weapon Systems	Tactical Effectiveness Reviewed	
Aerial Artillery System Concept Study - VTOL Aircraft, Parametric Study, September 1969, Boeing Document D210-10040-1	Missiles	Studied Various VTOL Aircraft but not Weapon Mountings					VTOL Aircraft Reviewed in Depth for Performance Data Shown on 13 Charts						
Cost and Schedule Addendum for Air to Ground Study of the 105/155mm Howitzer/RC-119, Contract DA-L1-010-AMC-103(V), April 1965	105mm and 155mm Howitzer	Firing from Cutout in Side of CH-47 Fuselage	Detailed Definition of Dynamic Analysis, Stress Integration, In-flight Gun Firing										
Cost Effectiveness Comparison of Artillery Systems for Support of Airmobile Operations by Research Analysis Corporation, AD381800, Feb. 1967	Rockets, Missiles, Howitzers, Recoilless Rifles	Analysis of Weapon Installation			Review of Blast Problems for Various Weapons	Brief Downwash Review			Overview of Survivability Analysis - Artillery Systems for of Ground Vulnerability of Helicopters		Cost Effectiveness Comparison of Artillery Systems for of Ground Vulnerability of Helicopters	Tactical Effectiveness	Operational Performance

TABLE II. AERIAL ARTILLERY DOCUMENTS

Title	Weapon Installation		Supporting Techn				
	Weapon Systems	Mounting Configuration	Stress and Dynamics	Flight Control	Blast	Navigation & Communication	Aero Perf
al Artillery Study Subtask 1.8 ysis of Ammunition and Fuel irements, Contract DAAH01-69- 116, July 1968	Howitzers, Rockets, Missiles	Attached & De- tached Firing Modes Studied for Various Helicopters					Brie was & H Perf Res
obile VTOL Artillery Weapons ems, May 1963, Boeing rt R-447	Howitzers, Rockets, Missiles	Attached & De- tached Firing Modes Studied for Various Helicopters	Brief Study of Recoil Loads	Review of Flight Control Degrada- tion Related to the Various Heli - copters			
ibility & Design Study of obile Artillery, Contract 1-177-AMC-108(T), April 1964	Howitzers, Rockets, Missiles	Comprehensive Group of Heli- copters' General Arrangement	Brief Study of Recoil Loads	Brief In- flight Stick Mo- tion Analysis Study	Brief Blast Overpressure Analysis	Night Flying Capability Navigation and Communi- cation Sys- tem Reviews	Heli Perf Char plet Brie nam
al Artillery System Concept ly - VTOL Aircraft Parametric ly, September 1969, Boeing ment D210-10040-1	Missiles	Study Consid- ered Various VTOL Aircraft but not Weapon Mountings					VTOL eraf vies Depl Perf Data on 1
and Schedule Addendum for Air ground Study of the 105/155mm tizer/HC-1B, Contract DA-11- -AMC-103(W), April 1966	105mm and 155mm Howitzer	Howitzer Firing from Cutout in Side of CH-47 Fuselage	Detailed Definition of Dynam- ics Analy- sis, Stress Integra- tion, In- flight Gun Firing				
Effectiveness Comparison of illery Systems for Support of obile Operations by Research ysis Corporation, AD381800, 1967	Rockets, Missiles, Mortars, Howitzers, Recoilless Rifles	Analysis of Weapon Inte- gration Problems			Review of Blast Problems for the Various Weapons		Brie was

TABLE II. AERIAL

Title	Weapon Installation		Stress and Dynamics	Flight Control	Blast	No Co
	Weapon Systems	Mounting Configuration				
Aerial Artillery Study Subtask 1.8 Analysis of Ammunition and Fuel Requirements, Contract DAAH01-69-C-1916, July 1968	Howitzers, Rockets, Missiles	Attached & Detached Firing Modes Studied for Various Helicopters				
Airmobile VTOL Artillery Weapons Systems, May 1963, Boeing Report R-447	Howitzers, Rockets, Missiles	Attached & Detached Firing Modes Studied for Various Helicopters	Brief Study of Recoil Loads	Review of Flight Control Degradation Related to the Various Heli-copters		
Feasibility & Design Study of Airmobile Artillery, Contract DA44-177-AMC-108(T), April 1964	Howitzers, Rockets, Missiles	Comprehensive Group of Helicopters' General Arrangement	Brief Study of Recoil Loads	Brief In-flight Stick Motion Analysis Study	Brief Blast Overpressure Analysis	No Co ar ce te
Aerial Artillery System Concept Study - VTOL Aircraft Parametric Study, September 1969, Boeing Document D210-10040-1	Missiles	Study Considered Various VTOL Aircraft but not Weapon Mountings				
Cost and Schedule Addendum for Air to Ground Study of the 105/155mm Howitzer/HC-1B, Contract DA-11-07C-AMC-103(W), April 1966	105mm and 155mm Howitzer	Howitzer Firing from Cutout in Side of CH-47 Fuselage	Detailed Definition of Dynamics Analysis, Stress Integration, In-flight Gun Firing			
Cost Effectiveness Comparison of Artillery Systems for Support of Airmobile Operations by Research Analysis Corporation, AD381800, May 1967	Rockets, Missiles, Mortars, Howitzers, Recoilless Rifles	Analysis of Weapon Integration Problems		Review of Blast Problems for the Various Weapons		

13

ARTILLERY DOCUMENTS

Supporting Technologies					Mission Effectiveness Evaluation		
Navigation & Communication	Aerodynamics and Performance	Fire Control Systems & Surveys	Target Acquisition	Survivability	Cost Effectiveness	Tactical Effectiveness	Operational Performance
	Brief Down-wash Effects & Helicopter Performance Reviews						Evaluation Performed of the Effects of Ammo Expenditure and Distance Upon Fuel Requirements and Aircraft Productivity
Light Flying Capability Navigation & Communication System Reviews	Helicopter Performance Chart Completed; Brief Dynamics Study	Fire Directions System & Artillery Survey Reviews	Review of Applicable Target Acquisition & Sighting Systems	Review of Countermeasures and Armor Study of Survivability	Cost Effectiveness Comparison of Candidate Weapon Systems	Tactical Effectiveness of Candidate Systems Reviewed	
	VTOL Aircraft Reviewed in Depth for Performance Data Shown on 13 Charts						
	Brief Down-wash Review		Overview of Survivability Analysis - Brief Analysis of Ground Vulnerability of Helicopters		Cost Effective Comparison of Artillery Systems for Airmobile Operations	Tactical Situations Analysis	Brief Analysis of Operational Performance & Systems Analysis for 3 Firing Modes

102

DEFINITION OF THE DESIGN MISSIONS

The general requirements of the approved QMDO, as expanded and explained in Reference 4, have been further expanded and detailed to provide specific design missions. These design missions are based mostly on judgment and trade-studies, and mission analyses are required to validate these mission details. The four missions shown should be considered as illustrations of the potential and the limitations of aerial artillery. The design does not vary greatly with the mission if all the firing modes are retained; however, the number of rounds carried can be traded against variations in mission radius, temperature, or altitude of takeoff, gun crew size, or more equipment, etc.

It may be noted that in the following three ground-to-ground design missions, only 36 rounds are fired, while 60 rounds are maintained for air-to-ground. This selection was based on the fact that the rounds for the air-to-ground firing had to be prezoned (to zone 5) and crimped before the flight. Therefore, these rounds could not as readily be replaced during the flight. Standard rounds could be delivered to the forward firing site by the logistics transport helicopters while these helicopters are delivering ammunition to other artillery sites. Also, since automatic loaders are provided for air-to-ground firing, there is a potential for firing more rounds in this mode. Further study of how the aerial artillery would be used is required to more firmly select the mix of rounds.

GROUND-TO-GROUND ATTACHED FIRING MISSION

The aerial artillery helicopter is to take off with a 9-man gun crew and the complete howitzer installation and equipment. Ammunition load will be 96 rounds with 36 of these rounds in readily removable containers and the remainder of the rounds in racks. Rounds in the racks will be loaded with zone 5 propellant and crimped for firing with the automatic loading system. All rounds will be fused on loading. This mission is summarized in Figure 4.

A running takeoff (rather than an OGE vertical takeoff) will be made so that the helicopter can be loaded to the alternate design gross weight at takeoff conditions of 2,000 feet pressure altitude and 95°F. At sea level standard conditions, a vertical takeoff (OGE) is required.

The helicopter will be able to fly to at least a 100-nautical-mile radius at an average cruise speed of 120 knots. During the flight, the weapon will be ready to fire air-to-ground at targets of opportunity and ready to be diverted to other higher priority missions. At the design mission radius, the helicopter will make a vertical landing at takeoff atmospheric conditions.

CH-47C WITH
T55-L-11 ENGINES

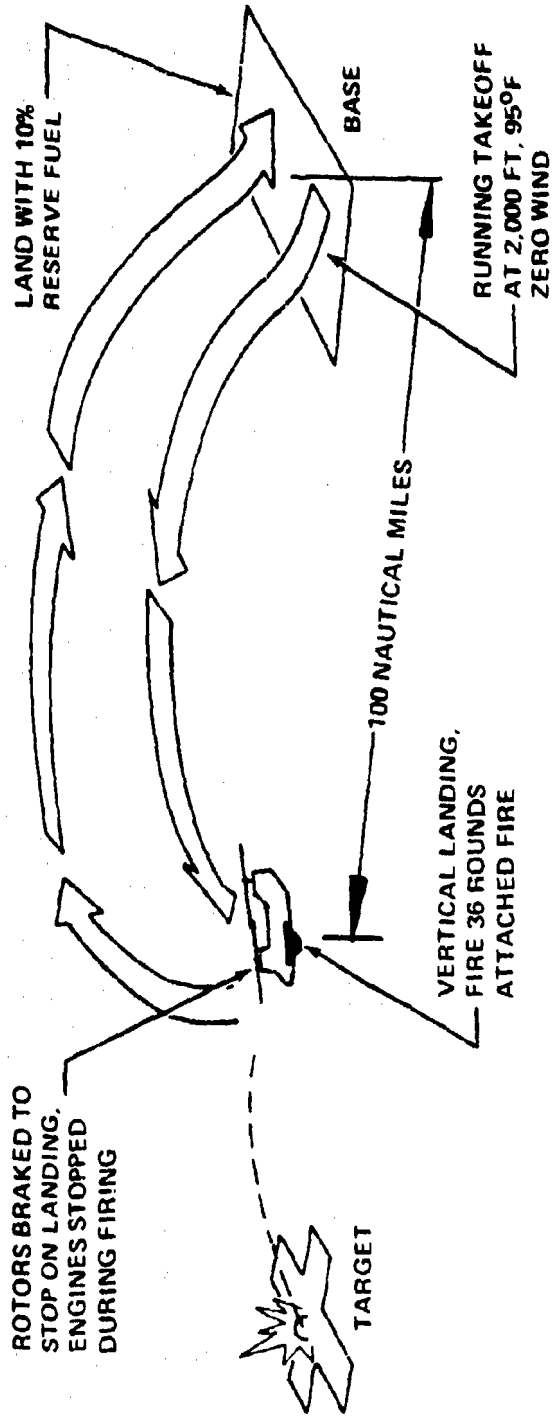

Figure 4. Mission 2, Aerial Artillery Ground-to-Ground Firing Mode (Howitzer Attached)

The rotors will be braked to a rapid stop, and the crew will quickly set up the attached fire howitzer. The engines will be stopped. Thirty rounds will be fired, retaining the remainder of the rounds to be ready for other targets obtained during the return flight. All empty cartridge cases will be recovered.

After the attached firing is complete, the howitzer will be returned to the travel position and the automatic loader reinstalled. The ammunition containers and empty cartridge cases will be returned to the helicopter, the engines restarted, warmed up, and the flight back to the base will be made with ten percent fuel reserve remaining at landing.

GROUND-TO-GROUND DETACHED FIRING MISSION (LAND TO DETACH)

As in the attached fire mission, the aerial artillery helicopter will take off with a full crew and equipment so that alternate targets can be attacked. At takeoff, the missions are almost the same. Less fuel is required on the return leg since the detachable howitzer, 36 rounds of ammunition, and a five-man gun crew are offloaded at the mission midpoint; but this is offset by the 15 minutes of hovering capability that are provided to find the landing zone and detach the weapon. This mission is summarized in Figure 5. Again, at least a 100-nautical-mile radius is required with a running takeoff and a vertical landing to unload the howitzer. The mission is flown at 2,000 feet, 95°F. The rotors are not stopped when the howitzer is being detached. Four gunners and 60 rounds are retained in the helicopter during the return flight so that other targets can be attacked. Ten-percent reserve fuel is required on landing at base.

GROUND-TO-GROUND DETACHED FIRING MISSION (HOVERING DETACHMENT)

This mission is identical to the detached firing mission with landing for detachment of the howitzer except in the details of how it is performed. The performance of the helicopter is identical. In executing the mission, the helicopter does not land at the midpoint. The left howitzer is detached and lowered to the ground from the hovering helicopter. The 36 rounds and the gun crew are lowered using the helicopter rescue hoist.

AIR-TO-GROUND FIRING MISSION

Again, as in the previously discussed missions, takeoff is with full equipment and men to provide for mission flexibility. The helicopter may perform a running takeoff and must fly a 95-nautical-mile radius mission. To acquire and attack the target, fuel for 15 minutes of hovering is provided at the mission midpoint. (This fuel allowance would provide about 30 minutes of low-speed loitering or several high-speed gun runs.) All 60

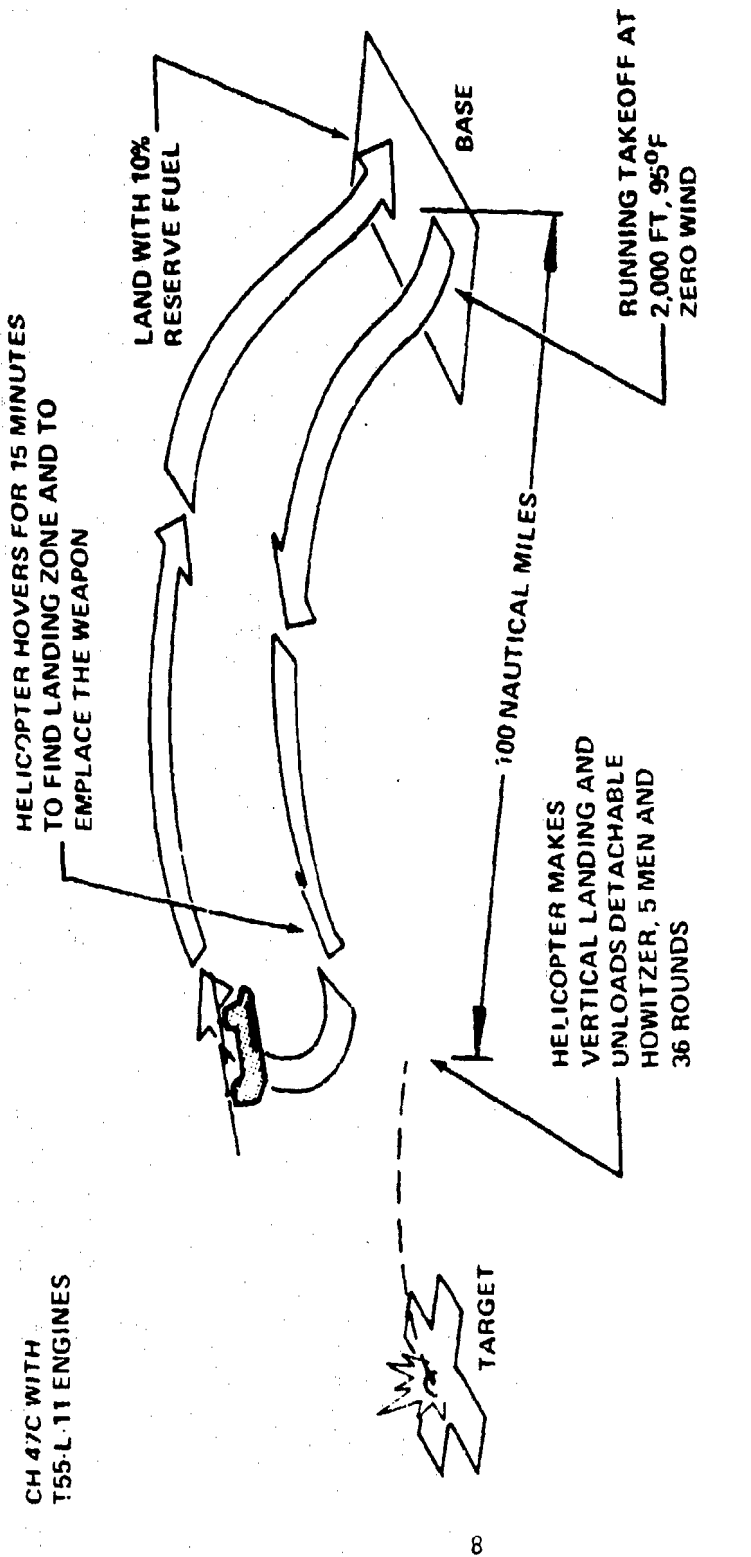

Figure 5. Mission 3, Aerial Artillery Ground-to-Ground Firing Mode (Howitzer Detached Hover Unloading)

rounds that were crimped with zone 5 charge for automatic loading will be fired during this attach mission. The 36 rounds which are in the removable containers for ground-to-ground firing could be rezoned to zone 5, crimped, and loaded into the automatic loader for firing during the return flight. This mission is summarized in Figure 6.

CH-47C WITH
T55-L-11 ENGINES

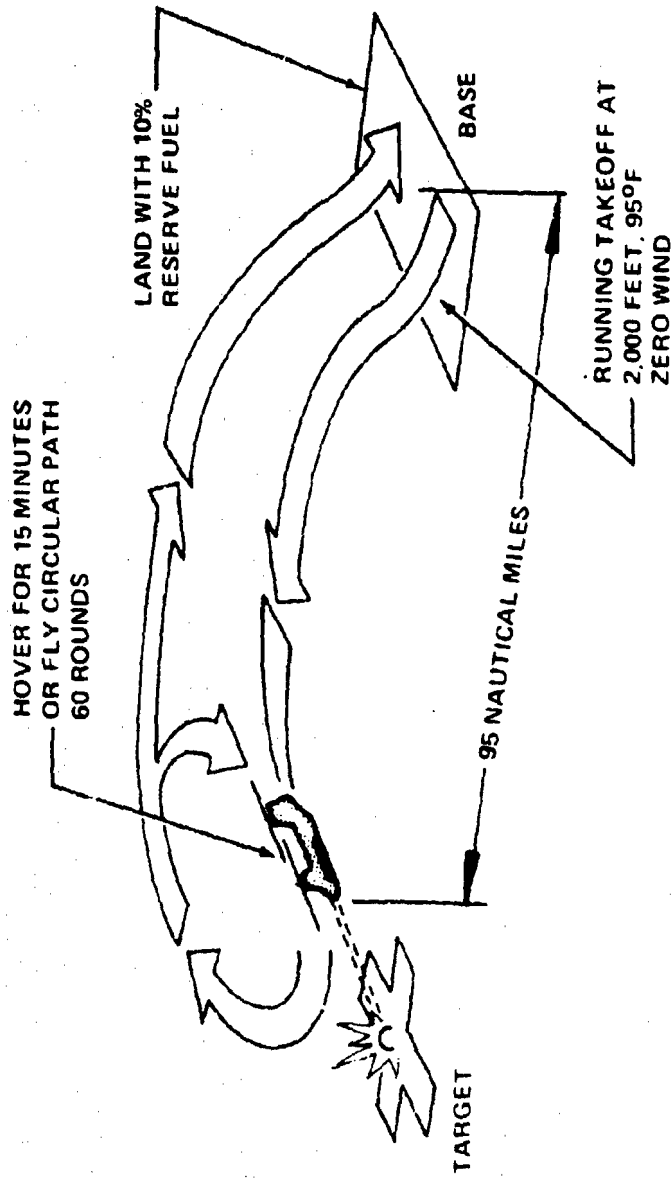

Figure 6. Mission 1, Aerial Artillery Air-to-Ground Firing Mode

DESIGN PHILOSOPHY

Philosophies used to establish the design presented in this report were an amalgam of the philosophies presented in Reference 4 and philosophies for mounting large items on helicopters that have been developed by Boeing. All these philosophical requirements that are achievable have been met. The concluding design will result in as simple, rugged and low-cost an installation as possible with the various required firing and operating modes.

WECOM CONCEPTUAL REQUIREMENTS

As noted in the following, the study contract configuration satisfies or exceeds the conceptual requirements extracted from Reference 4:

1. The system must be capable of delivering large volumes of fire in support of ground units. The contract configuration is capable of delivering 36 adjustable-zone rounds and 60 rounds of zone 5 in the ground-to-ground mode at normal firing rates for manual operation. The loaders for air-to-ground firing are sized for firing at 30 rounds per minute each.
2. The system must be capable of firing air-to-ground mode, using XM204 howitzer with impulse generator. The contract configuration includes provisions for firing air to ground with or without impulse generators. Both weapons are loaded by automatic feeders and fired by remote control. Impulse generators can be added to the system but they are not required.
3. The system is to have independent fire control with battalion augmentation. The contract configuration includes a fire control system consisting of standard ground artillery sights, etc. for ground-to-ground firing and a gunsight and laser rangefinder for air-to-ground firing. Battalion communication can be maintained by means of the radios in the helicopter.
4. Barrel-type ammo container should be used. Eighteen-round barrel-type containers are used to offload ammo for ground-to-ground detached firing of the left weapon. The containers may be lowered through the rescue hatch in hover mode or offloaded from the cargo ramp when the aircraft is on the ground.
5. One weapon must be detachable for ground emplacement, and the system must include the capability to offload this weapon from hover mode. The left-side XM204 may be offloaded on the ground or in hover mode. This weapon is a

- complete field piece and may be manhandled or transported by prime mover into position after detachment.
6. The system is to have effective communications. The radios in the helicopter will provide effective communications.
 7. Weight of the system shall not significantly degrade the performance of the aircraft. With the howitzer installation, the helicopter is capable of flying to the structural limits of the aircraft for the gross weights involved. Airspeeds in excess of the best range speed (approximately 110 knots) are readily achieved.
 8. The aircraft must operate in the same environmental elements as ground vehicles. The CH-47C is an all-weather aircraft, capable of operation in all environments including a temperature range of -65°F to +125°F.
 9. On-board and detachable fire control should be provided. The on-board fire control system consists of a simple gun-sight and a laser rangefinder. Ground-to-ground attached and detached firing are accomplished using the sighting and fire control equipment provided for field usage of the XM204.
 10. The single system must be capable of replacing close support cannon artillery. The system is capable of stand-off aerial bombardment for close support of ground operation. In addition, a single XM204 may be offloaded from hover for strategic deployment on the ground. The crew, plus 36 rounds of ammo, may be rapidly offloaded with this weapon. Sixty additional rounds can be offloaded individually from the ammo racks.
 11. The single system must be capable of firing antipersonnel, antimaterial, marking and screening smoke, illuminating, and chemical rounds. The system is capable of carrying all types of ammo and selectively firing it in the air-to-ground or ground-to-ground modes.
 12. Speed range and endurance of the system must be greater than airmobile maneuver force transport vehicles. The aerial artillery kit reduces the speed, range, and endurance capability of the CH-47C helicopter, but the modified helicopter appears to give adequate performance. A cruise speed of 120 knots and a 100-nautical-mile radius mission are achievable. This speed and range are compatible with airmobile maneuver force vehicles since this force is limited to the capability of the transport helicopter with external (sling) load.
 13. Growth potential for indirect fire from the air should be provided. Mounting of the weapons permits indirect firing

from the air; however, muzzle blast effects and ammo loading problems as well as rotor synchronization must be resolved.

14. Weapons easily transportable in case air movement not possible. The left-side weapon is a complete field piece and is easily detachable without the aid of ground equipment.
15. The system should be capable of firing special rounds, i.e., antiradiation, etc. when available. Firing the weapons is not limited by the helicopter in the ground-to-ground modes. Air-to-ground firing is nominally limited to zone 5 firing, but there is considerable margin provided in the design for firing the larger zones.
16. The system is to be rugged, reliable, simple, facilitate training, etc. The installation as configured represents the ultimate in ruggedness and simplicity.
17. Provisions for automatic ammo and impulse generator loading of the weapons in flight should be included. An automatic ammo loader is included. If it were necessary, a similar loader could be provided to load impulse generators.

ADDITIONAL BOEING CONCEPTUAL REQUIREMENTS

As a result of experience with mounting various items on helicopters and from discussion on the subject with likely users of the aerial artillery installation, the following additional design philosophies and goals were established:

1. The aerial artillery system shall be incorporated into the aircraft as a kit, easily attachable and removable. Installation and removal shall not require a crane or other special equipment. A design goal will be to install or remove the weapons kit within one hour.
2. The hardpoints provisions to accept the weapons kit shall not compromise the use of the aircraft in its primary mission as a cargo/troop transport.
3. The system and its attachments shall be simple and rugged in construction. The design shall incorporate proven technology.
4. The system shall require a minimum of airframe rework. Holes in the fuselage, which would adversely affect the structural integrity of the airframe, shall be avoided.
5. The study configuration shall be exposed to a human factors evaluation to ensure that all aspects of the system are operable.

6. The total aerial artillery kit installation shall not cause serious detrimental effects on performance and will not reduce stability or controllability of the aircraft.
7. To minimize cost, all fire control equipment will be the most simple equipment which will produce adequate accuracy. Existing conventional artillery fire control will be used for ground firing. Airborne firing will be designed for an accuracy of 15 mils, one sigma, error.
8. To provide for the continuous high gross weight and unusual flight profile operations inherent in armed helicopter operations, it will be assumed that the critical dynamic components of all helicopters which have had the weapons kit installed will be replaced after a reduced service life. Preliminary estimates indicate that reduced service life of some forward rotor blade components is involved.
9. In the preliminary design of the attachments for the aerial artillery kit, it was assumed that all components of the helicopter are already loaded to a significant portion of their strengths. Reinforcements have been provided to spread the load until the loads going into the basic structure are small. Detail design should show that the need for reinforcement can be reduced from that shown in this report.
10. Design of all components will be such that no single failure or single malfunction can result in serious injury to the aircrew, artillery group, or friendly ground personnel.

DESCRIPTION OF THE CONFIGURATION
AND FUNCTION OF COMPONENTS

The aerial artillery configuration selected for detailed study is composed of a CH-47C Chinook helicopter mounting two XM204 howitzers as shown in Figure 2. The weapon arrangement considered is essentially the same as that envisioned in the WECOM Aerial Artillery Concept document, Reference 4. The two howitzers are carried externally. The installation includes provisions for ground-to-ground attached firing of one howitzer and ground-to-ground detached firing of the other, as well as air-to-ground firing of both howitzers.

In Reference 4, the two ground-to-ground firing modes were accomplished using the left-side weapon. With the concurrence of RIA, the concept was changed in this respect; and the ground functions were divided between the two weapons. In the study configuration, the left-side weapon may be offloaded for detached ground-to-ground mode firing. The right-side weapon is fixed to the airframe and used for ground-to-ground attached firing.

For air-to-ground firing, the design provides for aerial direct firing forward of either weapon at a preset fixed elevation. The weapons are aimed by the copilot/gunner using a simplified fire control system consisting of a gunsight and laser range-finder. The copilot/gunner will aim the weapons in azimuth by using the directional controls of the helicopter. Elevation aiming will be accomplished by establishing the preselected air-speed and slightly changing the rate of climb so that the target is within the reticle of the gunsight when the helicopter is at the preselected range. Preselected airspeed can also include hover.

The howitzer installation is accomplished by incorporation of a hardpoints provisions kit on the helicopter which provides all the fittings, brackets, hydraulic and electrical fittings for the subsequent addition of the weapons kit. The hardpoints kit is installed with a minimum of modification to the helicopter and a minimum increase in empty weight. Weights of the various components of the hardpoints kit are:

<u>Item</u>	<u>Weight</u> <u>(lb)</u>
Internal Attachment Forgings (8 pieces)	25
Frame Reinforcements (6 frames)	60
Muzzle Blast Doublers and Reinforced Hatches	110

<u>Item</u>	<u>Weight (lb)</u>
Rotor Brake (to stop rotors for attached firing)	51
Brackets, etc.	<u>10</u>
Weight of Hardpoints Kit	256

The weapons kit attaches to the hardpoints kit with about 50 bolted connections. Attachments are designed to allow the installation or removal of the weapons kit within one hour so that dedicated helicopters are not required. The weapons kit includes the weapons and the supporting structures. Component weights for this kit are:

<u>Item</u>	<u>Weight (lb)</u>
Left-Side XM204 Howitzer	3,751
Right-Side Howitzer Modified for Firing Platform Operation	3,200
Box Beams (2) and Longitudinal Support Beams (4)	390
Retractable Beams (2), Latches, Drive Motors, etc.	1,577
Bearing and Attachments	80
Hoist Assemblies (2)	192
Right-Side Firing Platform	155
Internal Fuel Tank, Fittings, etc.	600
Ammo Feed System (Both Howitzers)	400
Ammo Racks	280
Air-to-Ground Sight, Laser Rangefinder and Reboresight Equipment	50
Artillery Group Fire Control and Other Carry-On Equipment	15
Weight of Weapons Kit	<u>10,690</u>

The left-side howitzer is a complete field piece with only minor modifications, and its installation on the aircraft also includes provisions for offloading from hover. The support structure for this gun is retractable, and a double hoist system, equipped with 100 feet of cable, is incorporated to lower the weapon to ground level.

The crew for ground operation of this howitzer may disembark with the weapon or may be already on the emplacement site. Once on the ground, the gun suspension system may be pumped down to the travel position and the weapon manhandled, or towed, to the desired location. Ammo is offloaded through the rescue hatch in hover or down the rear ramp with the ship on the ground. Army standard 18-round ammo drums may be used to transport the offloaded rounds. The system mission weight includes two 18-round ammo drums for ground-to-ground detached firing.

The offload procedure is reversed to pick up the left weapon for reemplacement or aerial firing. The howitzer would be prepared for hover pickup by putting the wheels, etc. in the travel position, with the cannon out of battery, and with the barrel set to a preselected angle. The forward and aft hoist harnesses, forward carriage spindle, aerial mount adapter channel, and magnetic breech actuation plate may be attached by the four-man gun crew within an estimated five minutes with the weapon in this position. (The magnetic breech actuation plate may be permanently installed if it does not interfere with manual operation of the breech.) After hookup to the twin-hoist system, the weapon is raised to a position slightly higher than its retracted support structure (see Figures 7 and 8). The structure is then extended and the weapon lowered into engagement with the aircraft. Securing of the weapon is accomplished by means of a mechanically-actuated lock at the spindle socket in the forward support beam and by two dogs which grip the aerial mount adapter channel by again retracting the aft beam.

Locking of the forward carriage spindle completes the electrical circuit to the permanently-installed linear motor on the howitzer mount which is used to fire the weapon remotely from inside the aircraft. Boresight realignment of the howitzer with the aircraft fire control system is accomplished by a retractable auxiliary optic tube which extends from the side of the fuselage into engagement with the M114 elbow telescope on the mount. The weapon is then aligned in azimuth by retraction or extension of the forward support beam while sighting through the optic tube at a fixed boresight target attached to the side of the aircraft. A vertical scale can also be provided on the target for determining an elevation boresighting correction in the reattachment sequence. The off and onloading sequence for the howitzer is identical whether the aircraft is in hover or on the ground.

STEP 1 PREPARATION FOR ON-LOADING

WEAPON IN TRAVEL POSITION. INSTALL AERIAL ATTACH FITTINGS. INSTALL HOIST HARNESS 2 PLACES. HOVER AIRCRAFT OVER WEAPON AND ATTACH HOIST CABLES.

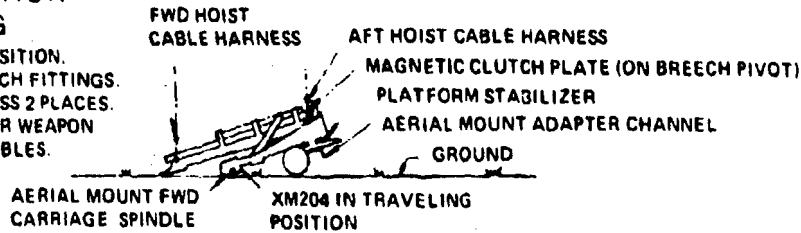

STEP 2 HOISTING WEAPON

HOIST OPERATORS AT WINDOWS 2 AND 3. RAISE WEAPON ABOVE RETRACTED SUPPORT BEAMS. RAISE MUZZLE END TO ALIGN MOUNT ADAPTER CHANNEL WITH AFT BEAM.

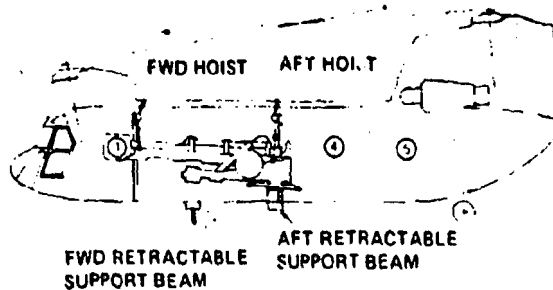

STEP 3 LOCATING WEAPON

EXTEND RETRACTABLE SUPPORT BEAMS. LOWER BREECH END OF WEAPON TO ENGAGEMENT WITH AFT RETRACTABLE BEAM.

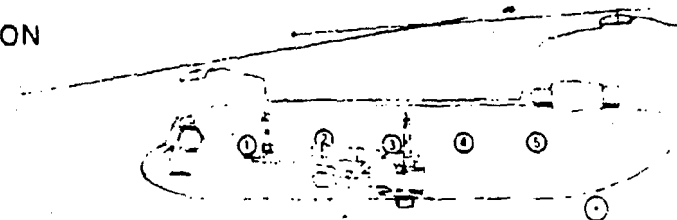

STEP 4 SECURING AND ALIGNMENT OF WEAPON

LOWER MUZZLE END AND ENGAGE CARRIAGE SPINDLE IN SOCKET IN FWD BEAM. BORESIGHT WEAPON. ACTUATE HOLD-DOWN DOGS AND LATCHES. PIVOT AMMO FEED SYSTEM INTO ENGAGEMENT WITH BREECH.

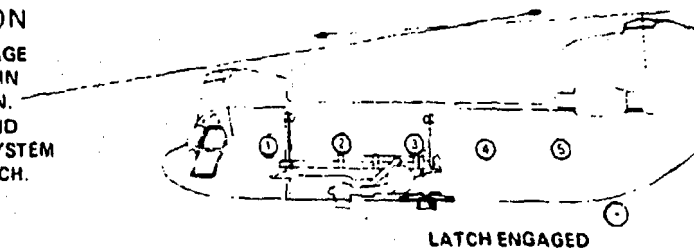

NOTE: HOIST CABLES REMAIN ATTACHED DURING FLIGHT

Figure 7. Left Weapon On-Loading During Hover Sequence

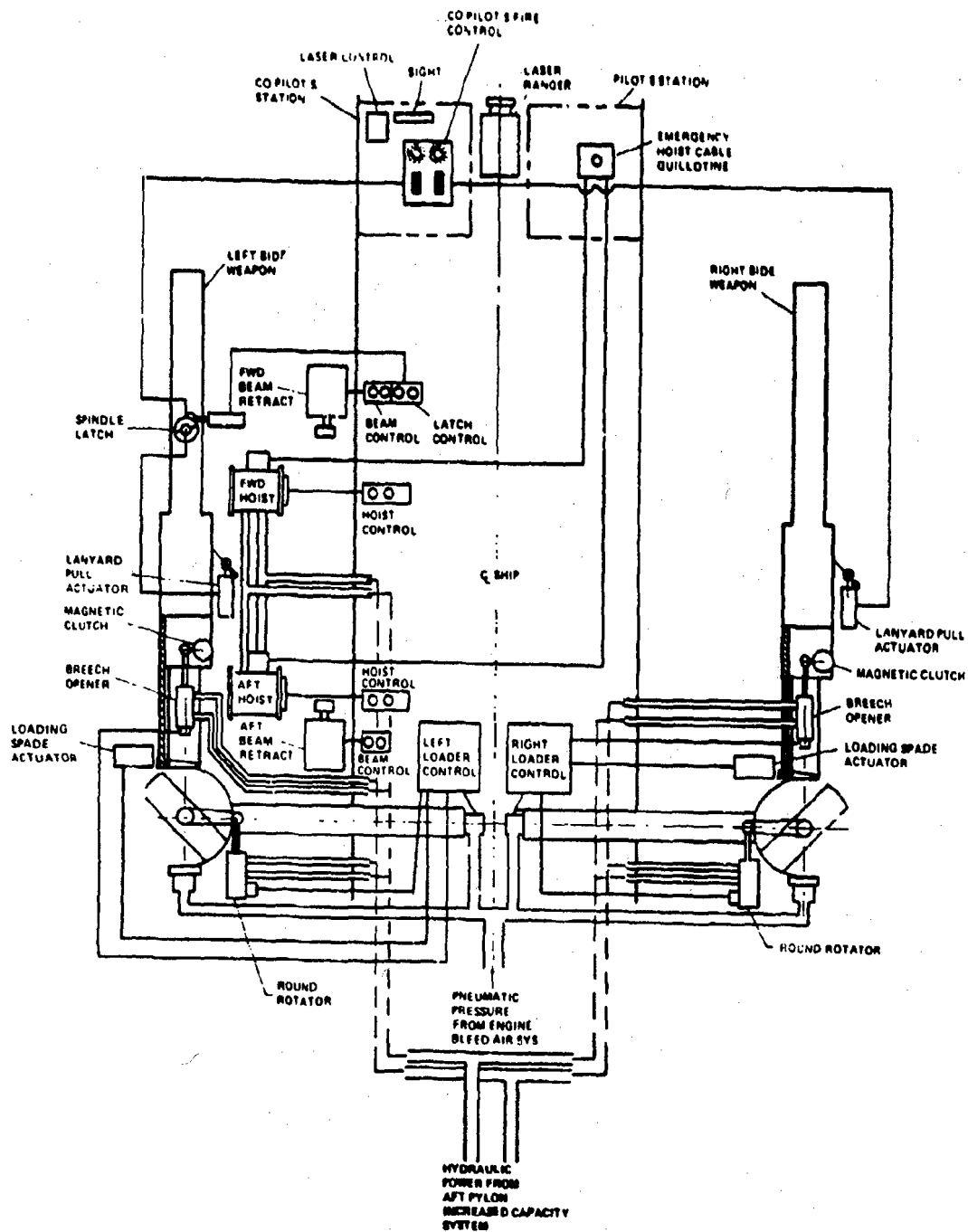

Figure 8. Aerial Artillery System Power and Control Schematic

The twin-hoist/retractable beam concept for providing loading and unloading from hover capability of the left-side weapon was selected after consideration of many alternates as the most simple, direct approach to answer this design requirement. In addition to the structure and mechanical complexities involved, the problem was also investigated from a human factors point of view. The step-by-step sequence of offloading and onloading the left weapon was examined by layout to ensure that this operation was not beyond the capabilities of the aircraft crew. The results of this layout study are summarized in Figure 7. The time required to offload the weapon and emplace for firing the first round depends on the situation on the ground. If the ammunition and gun crew are already on the ground, the terrain is suitable, and the howitzer can be lowered directly to the firing site, then the time required is mainly to set up the fire control sights and aiming stakes. Compared to setting up an XM204 field piece, the only additional times are about 30 seconds to lower the weapon to the ground and about one minute to remove the hoist cables and the three quick-attachment bolts that hold the adapter fittings to the howitzer.

The twin-hoist arrangement was selected to minimize weapon rotation, sway and pitch during hoisting operation in the hover mode. The retractable beam concept provides ease of removal and replacement of understructure, ample bearing surface for transmitting weapon static, vibratory and recoil loads to the airframe, and a convenient means of azimuth boresighting after onloading.

Weapon hoisting operations are controlled by two crewmen stationed at window numbers 2 and 3 on the left side of the aircraft. Each operator controls one hoist and one retractable beam. The hoists are standard lightweight, hydraulically-powered units with 2,000 pounds of operating load capacity at 100 ft/min lifting rate. Each hoist is attached to the end of a truss structure which is weapon kit-provided and when installed inserts into a hole in the upper fuselage and attaches to the airframe overhead structure. Vertical and longitudinal diagonal braces are provided outside to stabilize the hoist beam end. Hoist controls and hydraulic pressure and return lines are routed inside each hoist beam and are supplied with these kit-furnished items.

In addition to a winch control, each operator's station includes in/out control buttons for extension or retraction of the weapon support beams. These two support beams are of similar construction with an I-beam within a box beam. The inner I-beams are free to slide within the outer box beams which are fixed to the airframe. Each inner beam is extended, retracted, and secured by means of an airframe-mounted reversible electric motor driven pinion, meshing with a gear

rack on the bottom surface. The motors are wired through quick disconnects to switches at each operator's control station. The forward inner beam assembly incorporates an electrically-operated spindle latch for securing the weapon carriage. The aft beam assembly incorporates dogs which engage the aerial mount adapter channel upon retraction.

The right-side howitzer installation includes a fixed platform for crew operation on the ground. The suspension system is removed from this weapon and the traversing beam assembly replaced with a bracket and driven pinion which meshes with a gear rack on the underside of the platform edge. The traversing drive system is modified so that the azimuth handcranks drive the pinion, thereby training the gun in azimuth. A hand-actuated hydraulic jack to stabilize the platform against the ground is provided. The 4-man crew for ground operation of this weapon is carried aboard the aircraft. The gun may be trained 2,700 mils (150 degrees) from full forward in azimuth and -89 to +1,333 mils in elevation (by stopping the rotors with the rotor brake and moving the blades manually to an optimum position). For indirect firing on the ground with rotors stopped, the rotor blades must be rotated to provide maximum clearance for passage of the projectile and muzzle blast.

WEAPONS KIT AND HARDPOINTS PROVISIONS

The total aerial artillery system is attached to the CH-47C helicopter as a kit. Hardpoint provisions for attaching the kit are built into the selected airframe and do not compromise its use as a cargo or troop transport aircraft when the weapon kit is not installed.

The weapon kit (Figure 2) consists of the following:

1. Left-side XM204 Howitzer. Complete field piece with aerial artillery adapter fittings consisting of:
 - a. Forward carriage spindle
 - b. Aerial mount adapter channel
 - c. Magnetic clutch plate
 - d. Platform stabilizer
 - e. Hoist harnesses
 - f. Lanyard pull linear motor and electrical leads to carriage spindle
2. Right-side XM204 Howitzer. Modified to remove:

- a. Suspension system
- b. Traversing beam assembly
- c. Forward cradle and lunette
- d. Outboard portion of firing base

Add:

- a. Bracket and pinion gear azimuth drive and linkage to handcranks
 - b. Weapon platform attach hardware
3. Forward and aft box beams, longitudinal support beams, and attach bolts.
 4. Forward and aft retractable beams including latch dogs, spindle latch retraction motor pinions and gear racks, wiring controls and hardware.
 5. Forward and aft weapon hoist assemblies including hoist beams, struts, hydraulic plumbing and controls.
 6. Right-side weapon platform including secondary structure azimuth ring gear and attach hardware.
 7. Fuel cell fairings (4).
 8. Ammo feed systems, attach hardware, hydraulic and pneumatic plumbing and electric wiring and controls.
 9. Internal fuel tank and tie-down hardware, fuel system plumbing and transfer system to auxiliary tanks.
 10. Crew seats for nine men.
 11. Fixed ammo racks (2) for 60 rounds XM204 ammo plus cargo deck tie-downs.
 12. Ammo containers, drum type (2) with cargo deck tie-downs.
 13. Laser rangefinder, control, mechanical innerconnect and HUD sight.
 14. Retractable boresight tube and target.
 15. Miscellaneous carry-on-board equipment including:
 - a. Fire control quadrant

- b. Aiming posts
- c. Plotting board
- d. Small arms

Hardpoints provisions (Figure 3) include:

1. Muzzle blast skin and glass doublers.
2. Bracketry and electrical leads for laser rangefinder, HUD, weight and control.
3. Pylon window for laser rangefinder.
4. Reinforcements for fuselage frames 160 through 360.
5. Forward and aft beam attach forgings.
6. Rotor brake installation.
7. Engine bleed air system modification to provide pneumatic power for ammo feed system.
8. Hydraulic system modification to provide increased capacity for weapon hoists and ammo feed system.
9. Fuel system modifications to accommodate elimination of main external tanks and incorporation of internal tank.

Hydraulic power to drive the hoists and ammo loader controls of the weapons kit is obtained from the ship's utility hydraulic system. The hardpoints kit will provide all the modifications to the hydraulic system which would be difficult to remove. These modifications would be similar to those which have been designed and fabricated for conversion of the CH-47C to the Model 347. The existing pump, mounted on the accessory drive gearbox, aft transmission, needs to be replaced with an increased capacity unit. No change is required to the mounting pad and attachments. Large diameter, low loss, pressure and return lines bypass the existing utility system valve and are routed forward along the right-side shoulder of the fuselage to system shutoff valves near station 312. These lines, pump and shutoff valves are part of the removable aerial artillery weapons kit and do not contribute to the empty weight of the aircraft when the kit is not installed. Some increase to the capacity of the present utility hydraulic system reservoir may be required to handle the added volume imposed by the weapons kit. Detail design and analysis of the kit hydraulic system will dictate the extent of this change.

As part of the airframe rework to incorporate the hardpoints

provisions, quick-disconnect connections for three additional DC circuits will be installed in the aircraft. The weapon kit will provide electrical power supply cables routed aft from the DC junction box in the forward cabin to plug-in receptacles for the aerial artillery kit near station 312. These cables will be tied to the fuselage frames as necessary as the kit is installed. Separate electrical receptacles will be provided in the power supply cables for the beam retraction, series-wound high-torque motors and for the control and actuation systems of each ammo feed system. Initial evaluation indicates that no addition to the present ship's power generation system will be required. Empty weight increase due to the added DC circuits is estimated to be negligible.

Pneumatic pressure for the ammo feed systems is supplied by the CH-47C engine bleed air system. Only a small percent of the 74 psia available from the customer bleed ports is needed to transfer rounds from the ammo racks outboard and forward to the standby tubes behind the weapons. The existing anti-ice bleed port valves on each engine are replaced with valves incorporating bypasses and a connecting manifold from which the combined bleed flow may be ducted downward and forward to a heat exchanger installed in one of aftermost cargo compartment windows. Temperature of the air at this point should be less than the 560°F at the bleed ports. Downstream from the 0.8 ft² heat exchanger, air temperature will be less than 160°F. The bleed air manifold, ducting, and heat exchanger are included in the ammo feed system weight and are part of the weapons kit. Anti-ice bleed valves incorporating bypass ports for the ammo feed system manifold will be part of the kit provisions. The weight of these modified valves is estimated to be negligible.

INSTALLATION PROCEDURE FOR WEAPONS KIT

Installation of the aerial artillery kit to the hardpoints-equipped CH-47C helicopter starts with the addition of the hoist beam, strut, and hoist assemblies which weigh 96 pounds each and are inserted and secured at the fuselage shoulders at stations 160 and 320. Hydraulic power is connected to the hoists, utilizing the modifications to the ship's system provided as part of the hardpoints kit to provide increased capacity and the required connections. The main fuel cells are removed from both sides of the aircraft and stored for future reinstallation. The two box beams are positioned under the helicopter. The aft box beam, which weighs 265 pounds, may be lifted into place using the aft weapon hoist on the left side and the screw-jack firing base on the right side, and manpower to stabilize the load. The forward box beam weighs only 77 pounds and may be manhandled into contact with its hardpoint attachments on the underside of the aircraft. The aft retractable beam may be inserted into its supporting aft box beam using the aft winch plus manpower. The forward

retractable beam, weighing 469 pounds, can be inserted using manpower. After installation of the stiffening structure and the crew platform, right-side weapon may be ground-hoisted into position. Additional fittings could readily be provided so that the Chinook maintenance crane could be used to lift this howitzer into place if an additional crane is found to be required. The right-side weapon installation is complete when the azimuth drive pinion and platform gear rack are intermeshed. The ammo feed system assemblies are installed through the number 4 windows on both sides of the aircraft and adjusted to the breech location of the weapons. The internal crew accommodation, ammunition racks and drums, and auxiliary fuel system pick up existing cargo deck tie-down fittings. Left weapon boresighting equipment and fire control sight and ranger attach to previously installed hardpoints kit bracketry. Electrical, hydraulic, and pneumatic power supply for the kit are connected to hardpoints kit-provided quick disconnects. Routing of the required power supply lines is schematically shown in Figure 8. Kit installation procedure is complete after the attach fittings have been installed on the left-side howitzer and the weapon hoisted into place and secured on the support structure.

AUTOMATIC AMMUNITION FEED SYSTEM

For the air-to-ground firing mode, ammo loading is accomplished remotely from inside the aircraft using a mechanical feed system (see Figure 9). The rounds are hand-loaded into a pneumatic tube inside and transported by engine bleed air pressure to a rotating cylinder in line with the howitzer breech. Bleed air pressure is again utilized to move each round into the standby tube immediately behind the breech. From this point, an electric ram loads the round into the gun. The breech is opened and closed in sequence with the loading and firing by means of a hydraulic cylinder and magnetic clutch engaging an extension of the breech pivot. The total loader assembly is rotated upward hydraulically before firing. After firing, the casing is ejected upon opening the breech; and the casing is deflected downward into a net by a curved plate on the underside of the loader.

The ammunition feed system uses on-board pneumatic, electric and hydraulic power. It is quickly removable and is mounted in a window so it does not require a special opening in the fuselage structure. For ammunition supply to the right-side howitzer for ground-to-ground crew operation, the outboard element of the loader may be removed and the remaining tube utilized for transfer of rounds from inside for manual loading on the gun platform. A firing rate of 120 rounds per minute is possible in the aerial artillery air-to-ground mode using both weapons and the ammunition feed system.

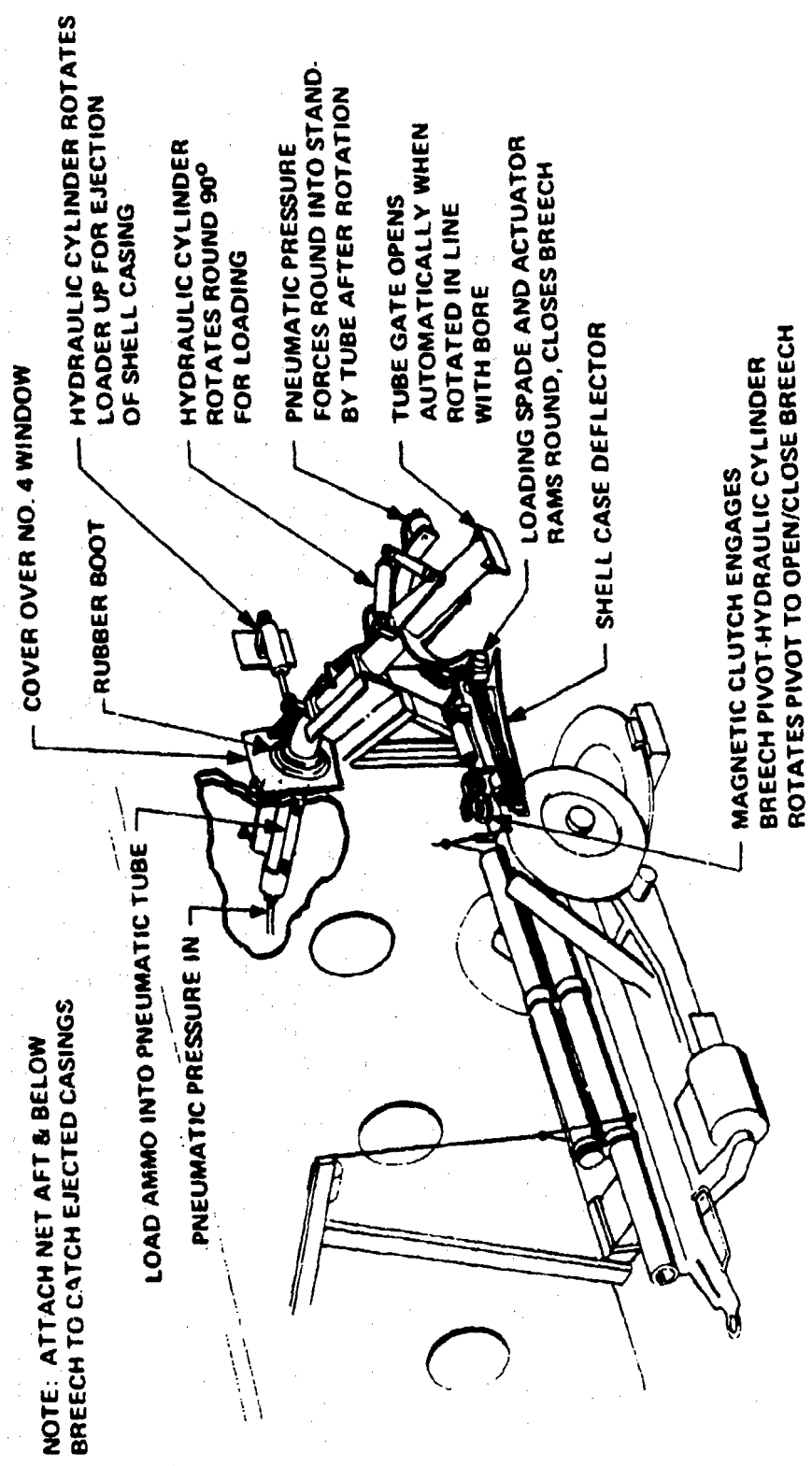

Figure 9. Pneumatic Ammo Feed System Installation in Number 4 Window

STRUCTURAL COMPONENT SIZING CONSIDERATIONS

The structural components of the weapons kit and hardpoints provisions, shown in Figure 10, are sized to provide load paths to carry loads generated by the weapon installation into the helicopter structure. Design of these load paths is complicated by the need for the ability to install the hardpoints provisions in the field during other maintenance. Also, these load paths must provide for rapid field installation of the weapons kit. In general, these load paths are sized by the 8g crash loads vertically and recoil malfunction loads laterally and longitudinally. The vertical and lateral crash load paths are along the box beams up through the fuselage bottom skin into the beam attach forgings and into the frames. Longitudinal loads are distributed to the structure by the longitudinal support beams and the lower longeron of the fuselage. Details of the calculations involved in sizing these components are presented in Appendix IV. In this section, the sizing of components for malfunction and crash loads is discussed based on limit load considerations, followed by a discussion of the sizing for normal flight and firing loads based on fatigue considerations. Vibration tuning of the mounting structure has also been considered to ensure that the large mass of the howitzer installation will not significantly increase helicopter vibration.

MALFUNCTION AND CRASH LOAD PATHS

Malfunction during firing of the weapons produce loads that design the supporting structure. These malfunctions may occur in flight or on the ground and may result in longitudinal ultimate design loads up to $36,500 \times 1.5 = 54,750$ pounds from either weapon in flight or the same load in a lateral direction from the right-side weapon on the ground. As with normal firing, malfunction loads originate at the barrel centerline and are transmitted to the firing base via the cradle, trunnions, and mount. Longitudinal loads from the left-side howitzer enter the two retractable beams through the adapter channel and spindle and are transferred to the box beams by means of internal bearing surfaces. The retractable beams are steel, American standard "I" cross-section with the webs oriented horizontally. The forward beam measures 5 x 12 inches; the aft one, 9 x 20 inches. The box beams are steel with .06-inch wall thickness and with internal dimensions to provide bearing surfaces for the retractable beams. From the box beams, the loads are taken in shear through bolted connections, four places, on the bottom corners of the fuselage. From these points, loads are taken in compression by the 2 x 2.5 x 1.88-inch wall, aluminum alloy channel section of the longitudinal

support beams which are added as kit items on the outside bottom corners of the fuselage. It should be noted that the elastic stability of these channels is ensured by their attachment to the fuselage skin and frames. The loads are transferred from these beams through shear attachments over a 180-inch length of the side and bottom fuselage skins to provide adequate shear distribution to the stringers and longerons.

Loads from the right-side howitzer are taken from the firing base through one 10 x 20 x .06-inch wall steel box beam with a center web and weapon platform secondary structure for similar shear distribution through the skins to the stringers and longerons.

Right-side weapon malfunction recoil loads, during ground-to-ground firing, are transmitted via the single main box beam member and enter the fuselage corners as a lateral load which may also have a downward component, depending upon the elevation at which the weapon is fired. The lateral component of this load is transmitted by means of the hardpoints provisions forgings installed between frames 280 and 320 for shear distribution to the bottom of the fuselage. The vertical component due to weapon elevation comes out as tension and compression across the bottom corners of the fuselage. With increases in elevation, an increasing compression load is transmitted to the ground through the platform screwjack under the firing base.

Misfire loads are up to 29,250 pounds and in the opposite direction from normal or malfunction recoil loads. With the weapons pointing forward, misfire loads are reacted in an opposite sense and come out as tension in the longitudinal support beams at the corners of the fuselage. Load distribution in the airframe, however, is accomplished through shear at the stringers and longerons over the same 180-inch length of side and bottom skins as for the aft malfunction load. Misfire at the right-side weapon creates tension in the main box beam and is transmitted to the fuselage corners and comes out as shear across the bottom skins. Misfires with the weapon elevated produce the opposite effect from recoil malfunctions. The load enters the airframe as compression and tension at the fuselage bottom corners and is absorbed as torsion in the fuselage cross-section.

LOAD PATHS FOR NORMAL OPERATIONS

In this study, it was found that only the hoist beam assemblies are designed by normal operating loads. This is mostly due to the large magnitudes of the crash and malfunction loads, but it is expected that subsequent detail design efforts will show that normal flight vibratory loads design some portions of the fittings and other structures. This will be particularly true if the large vibration of the howitzers can not be reduced by tuning of the structure. High-cycle fatigue damage of all

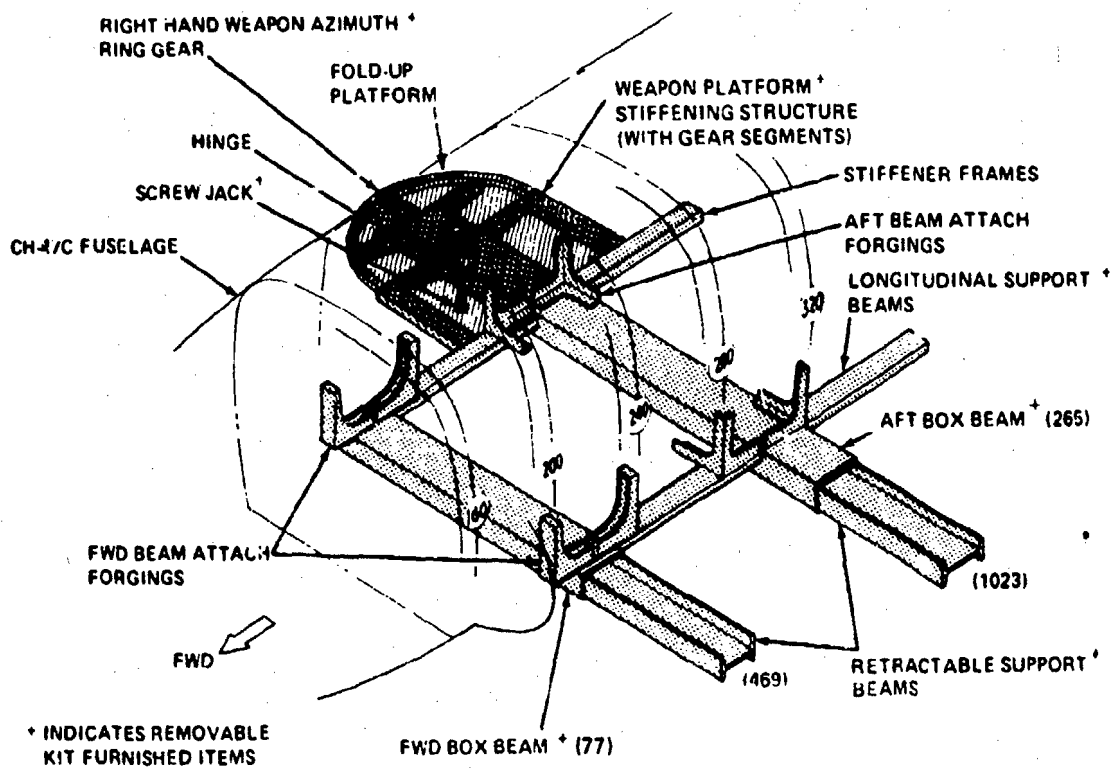

Figure 10. Aerial Artillery System Weapon Support Structure

the normally flight-loaded support structures needs to be studied in detail.

Normal operating loads design the hoist beam assemblies. The two identical weapon hoist structures are fabricated from 6 x 6 x .06-inch wall aluminum alloy box beams. The 16,800-pound load transmitted by the hoist structures is based on a 3g vertical load factor times 1.5 ultimate design load. Each hoist assembly is attached to the airframe at three points: two internally at the upper shoulder of the fuselage; and one at the outside lower corner. All points are bolted shear attachments. Hoist loads are reacted as torsion in the fuselage cross-section. Figure 11 shows the hoist beam assemblies.

Normal operating loads would also be expected to design some portion of the ammunition loaders. These lightweight loaders will experience many cycles of fairly high loads as the rounds are transported into the howitzers. The loaders also experience helicopter vibration, and the supporting structure will have to be tuned to provide vibration isolation. Resolution of these problems needs to be accomplished during detail design.

WEAPON AND HELICOPTER VIBRATION PREDICTION

Results of the dynamic analysis of the CH-47C helicopter with the weapons kit installed show a generally satisfactory preliminary design and are summarized in Figure 12. These results show that the longitudinal and lateral accelerations of the howitzers are large (about 0.5g) with reduced helicopter vibration. This indicates that the howitzers are acting as vibration absorbers in the lateral and longitudinal directions. Vertical accelerations of the howitzers are small with significantly increased helicopter vibration. The vertical stiffness of the mounting structure is such that the vertical motions of the howitzers are isolated from the helicopter. This design is acceptable for helicopter vibrations if additional vertical vibration absorbers are provided.

The predicted howitzer vibration causes 3 mils maximum angular excursion of the barrels, which is a small part of the total aiming error. This vibration magnitude needs to be considered further since it could introduce fatigue loading problems in the hardpoints attachments. In subsequent detail design efforts, continued detail dynamic considerations of the howitzer attachments are necessary. Somewhat increased vertical stiffness and reduced lateral and longitudinal stiffness should be explored to reduce vibration changes to the treatments for vibration reduction such as the existing vibration absorbers and cargo floor isolation.

The methodology used in this study calculates the response of the analytical model of the airframe as a result of the

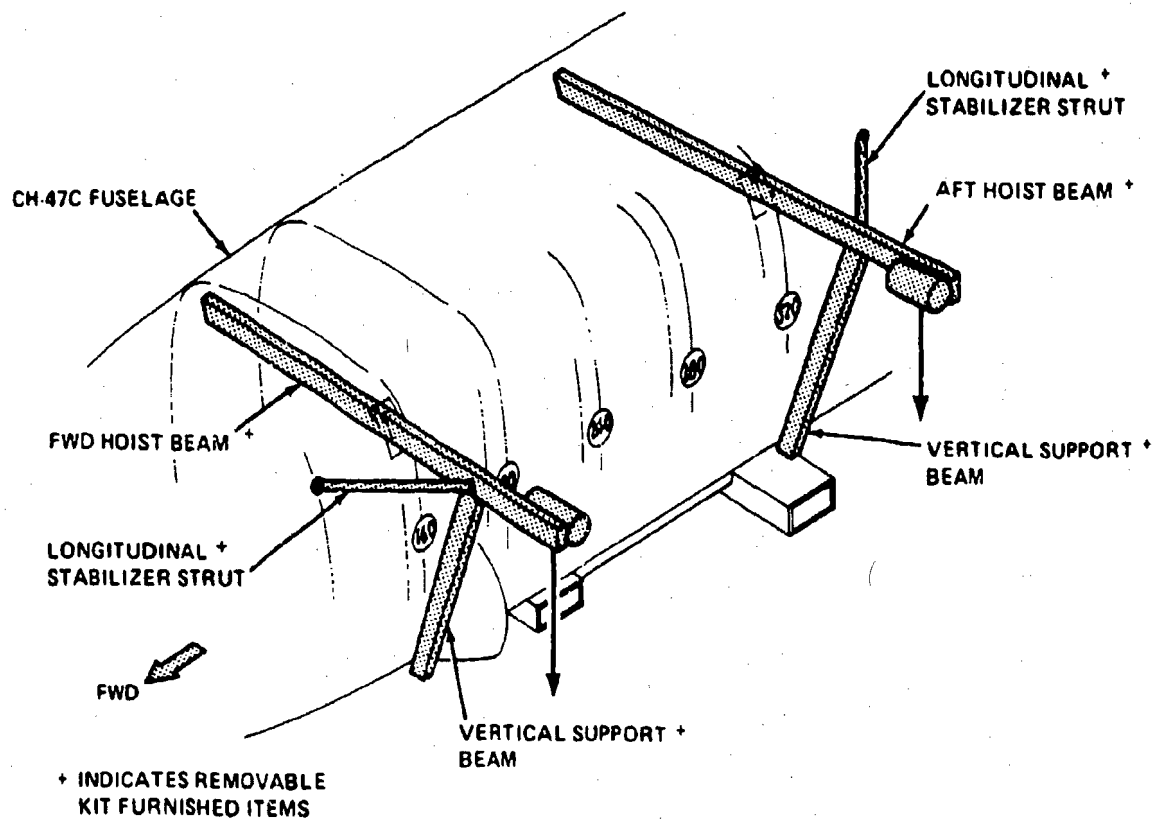

Figure 11. Aerial Artillery Left Weapon Hoist Structure

@ 235 RPM AND 135 KNOTS

NO VIBRATION ABSORBERS

--- CH-47C

— CH-47C AAWS

*GUN CG VIBRATION LEVEL

LONGITUDINAL 3/REV

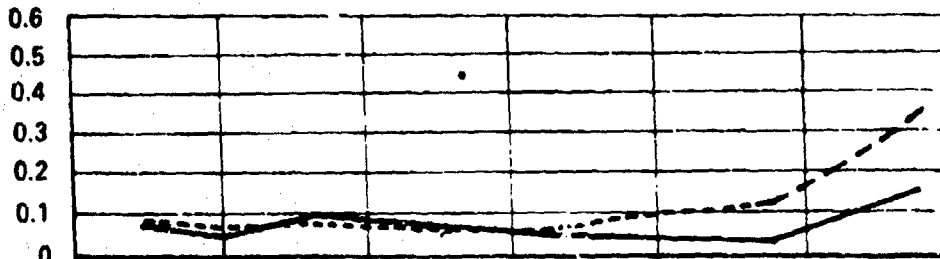

LATERAL 3/REV

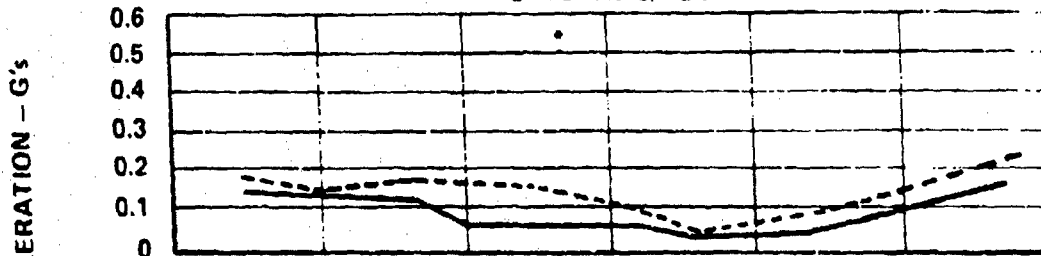

VERTICAL 3/REV

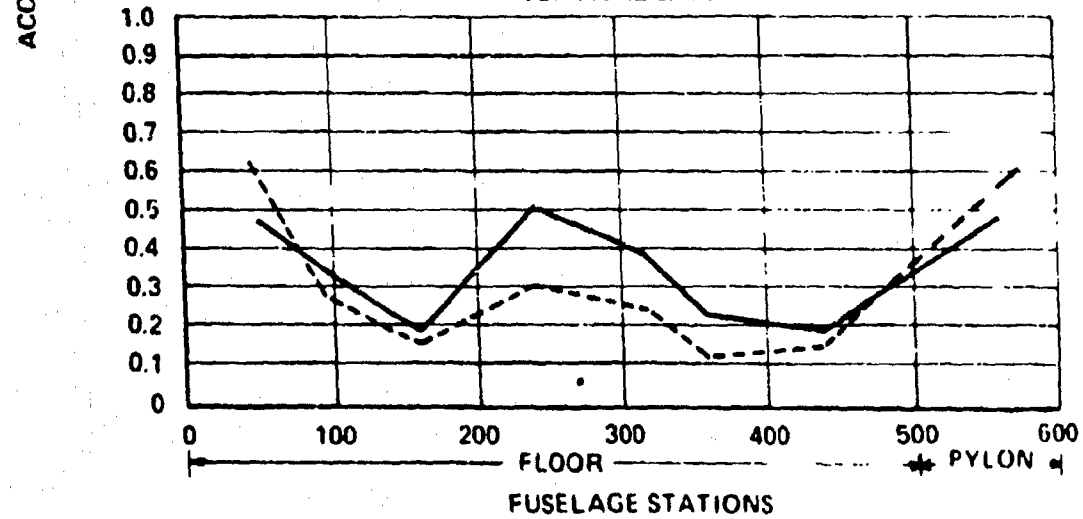

Figure 12. CH-47C and CH-47C AAWS 3/Rev Vibration Comparison

predicted rotor loads from the D-88 rotor aeroelastic analysis. In previous studies, this analytical vibration prediction method has shown excellent agreement with measured flight data. The validity of the airframe analytical model has also been substantiated by extensive ground shake testing. The CH-47C airframe analytical model provided the baseline structural model on which the aerial artillery weapons and support structure were superimposed. The nodal grid system of the CH-47C airframe and that of the weapon supports is shown as Figure 13. The basic structural representation of the CH-47C airframe contains 2,142 structural elements and 1,745 nodal degrees of freedom. This array has been reduced as a result of previous studies to 133 degrees of freedom. For this study, the aircraft was divided into four substructures: forward pylon, gun support structure, mid-cabin, and aft pylon. The substructures used in the analytical solution are also shown in Figure 13. Modifications were made to the baseline configuration in substructure number 2 which extends from fuselage stations 160 to 320 for support of the weapon platform. Idealization of the structure in this region required 80 additional structural elements. The remaining substructures were identical to that of the baseline aircraft. Three linear motions and three rotations were considered to be an adequate definition of the weapon system dynamic response at the CG position of each gun.

The vibration solution flowchart for the AAWS study is given in Figure 14. Each substructural stiffness matrix was generated separately and merged into a total system stiffness matrix which is reduced to 138 degrees of freedom for the dynamic response solution. Considering the discrete mass of each retained degree of freedom, the dynamic matrix is formed and solved for the eigenvalues and eigenvectors. Using a modal representation of the structural dynamic properties, i.e., natural frequencies and modes, the airframe vibration resulting from the predicted flight loads (D-88 aeroelastic rotor analysis) is determined by a damped forced response solution. The solution requires approximately 2-1/2 hours of IBM 360/65 computer usage with 1/2 hour to generate a weapon platform substructure and approximately two hours to merge the subsystem and perform the dynamic solution.

In the design of the aerial artillery weapon kit supports and attachment structures, the dynamic requirements considered were:

- Acceptable (3/rev) fuselage vibration
- Vibration of the weapon platform must be sufficiently low to allow adequate sighting accuracy of the guns in the firing mode.

The baseline configuration considered was a CH-47C aircraft with no vibration treatment and having a gross weight of

SUBSTRUCTURE	LOCATION	PROMINENT ITEM
1	STA 0 - 160.0	FWD PYLON
2	STA 160 - 320.	GUN SUPPORT
3	STA 320. - 482.	MID CABIN
4	STA 482. - 594.	AFT PYLON

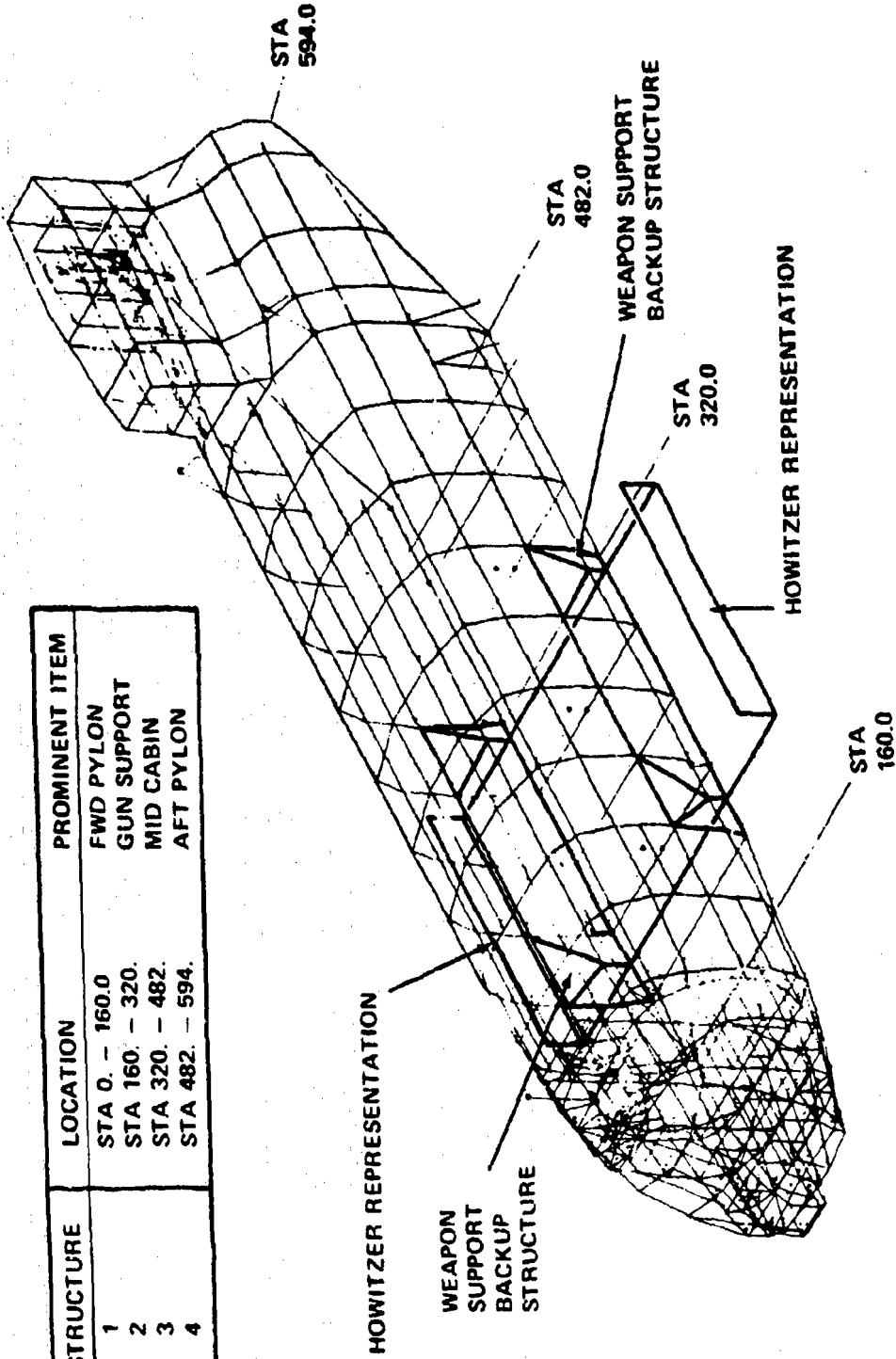

Figure 13. Structural Model System Used for Dynamic Analysis

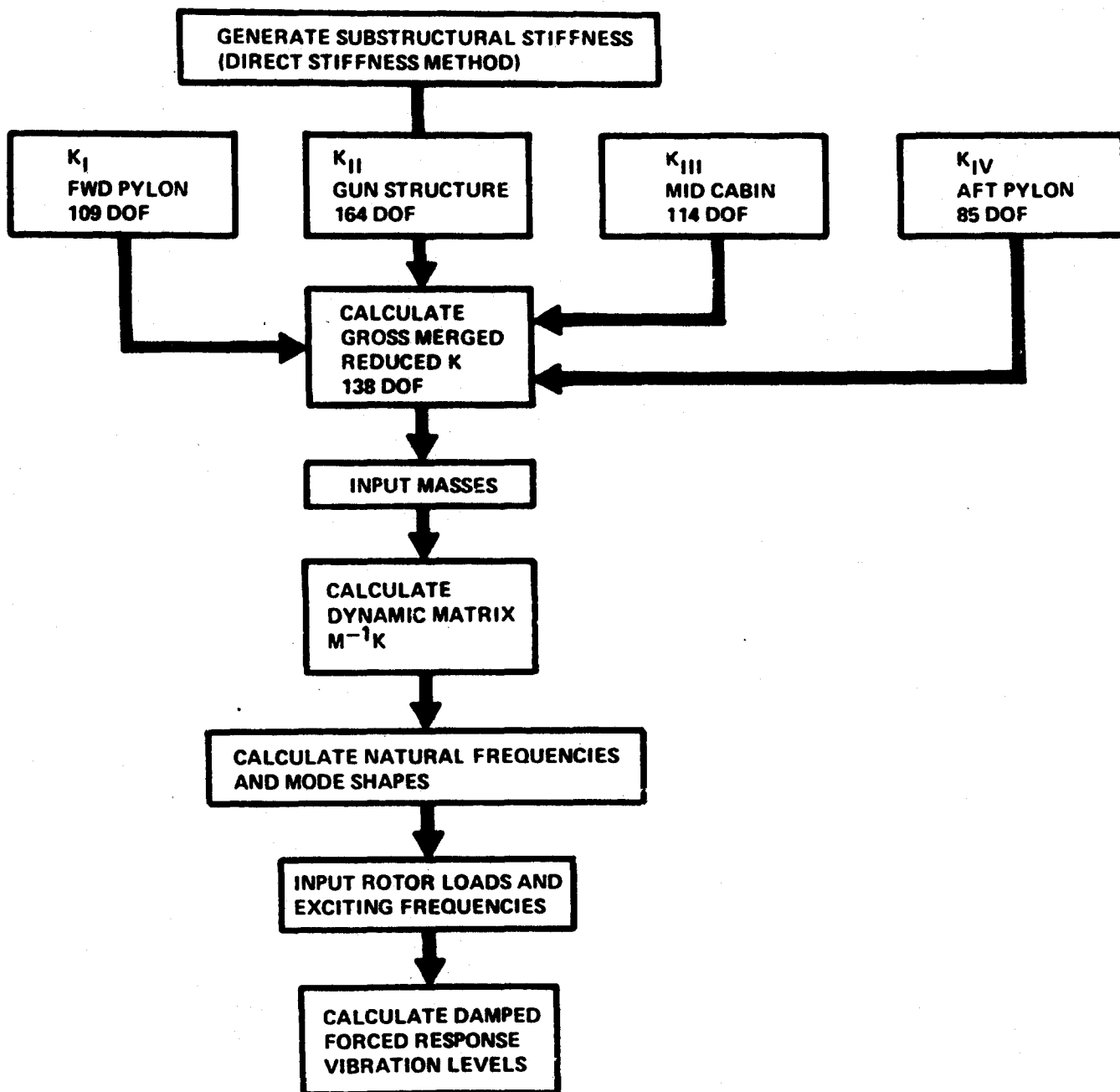

Figure 14. Flow Diagram for Airframe Forced Vibration Calculations

20,000 pounds. The weapon and supports for transporting and firing a right and left-side 105mm howitzer were assumed to add approximately 3,200 and 3,750 pounds, respectively. The assumed gross weight was significantly less than that which resulted from the final design.

Natural frequencies of the helicopter with the howitzer installation and the baseline aircraft are tabulated in Table III. As shown, the weapons kit causes two new frequencies to appear which are the first and second vibration modes of the gun on the support beams. Preliminary sizing of the support structure provided for isolation of the vertical gun motion from airframe excitation by tuning the uncoupled vertical symmetrical bending mode of the weapon platform below the 3/rev forcing frequency. As illustrated in Figure 15, the gun modes resemble the first bending and first chordwise modes of a high aspect ratio wing. Further, it is noted that the only frequencies significantly altered with the attachment of the weapon system are those frequencies for modes which contain significant lateral motion. This can be attributed to the high lateral stiffness of the gun installation which approximates a rigidly-mounted lumped mass attached to the helicopter in the lateral direction. In the vertical direction, the right and left gun masses are virtually isolated from the fuselage as a result of the soft vertical stiffness of the support beams. The most significant frequency change occurs in the fuselage racking mode, the frequency of which is reduced from 11.09 to 7.71 cps. This change is attributed to the relatively large mass of the gun support system rigidly attached laterally to the airframe and acting in a mode with significant lateral motion. The vibration modes which contribute most of the vibration are illustrated in Figure 16.

A summary of predicted vibration levels is presented in Figure 12 and discussed in detail in the following:

LONGITUDINAL VIBRATION

Fuselage

Longitudinal vibration forward of fuselage station 300 with the howitzer-equipped aircraft is comparable to the acceptable levels of the baseline aircraft. In the aft pylon region, the vibration with the howitzer installation is approximately twice that of the basic aircraft. Since this region is unoccupied, this increase in vibration is probably acceptable, but component stresses would have to be checked.

Gun CG

Longitudinal vibration of the howitzer at 0.45 g's is approximately nine times that of the fuselage at the attachment. The

TABLE III
 MODEL CH-47C AAWS AND CH-47C FREQUENCY COMPARISON

MODE NO.	AAWS FREQ - CPS	CH-47C FREQ - CPS	DESCRIPTION
1	5.93	6.17	AFT PYLON LATERAL
2	6.33*	--	FIRST GUN MODE (VERT. BEND)
3	7.71	11.09	LAT. MODE (FRAME RACKING)
4	8.33	8.31	AFT PYLON LONGITUDINAL
5	9.21	9.83	LATERAL MODE
6	12.22	12.20	FORWARD PYLON LONGITUDINAL
7	13.96**	--	SECOND GUN MODE (TORSION)
8	14.41	14.41	VERTICAL MODE
9	14.85	14.55	LATERAL MODE
10	15.02	15.70	LATERAL MODE

FIRST GUN SUPPORT MODE

** SECOND GUN SUPPORT MODE

SECOND GUN MODE
f = 13.96 CPS

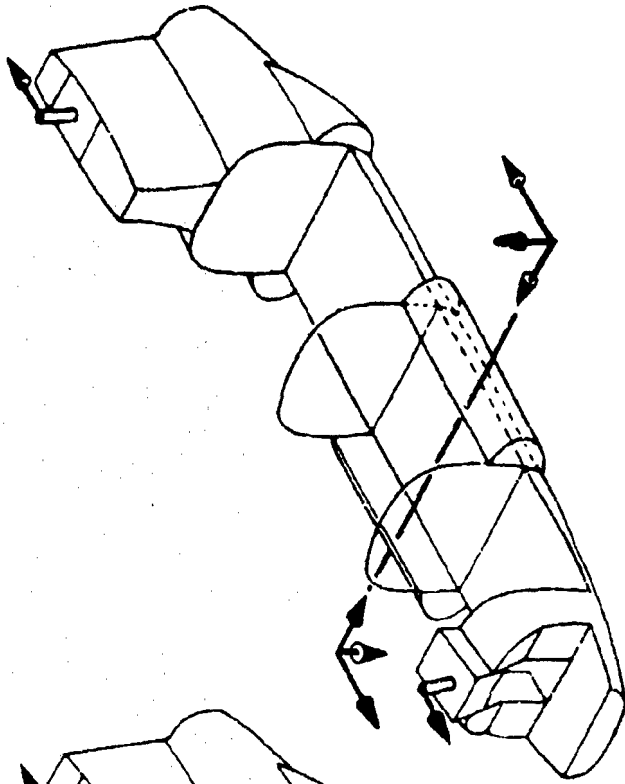

FIRST GUN MODE
f = 6.33 CPS

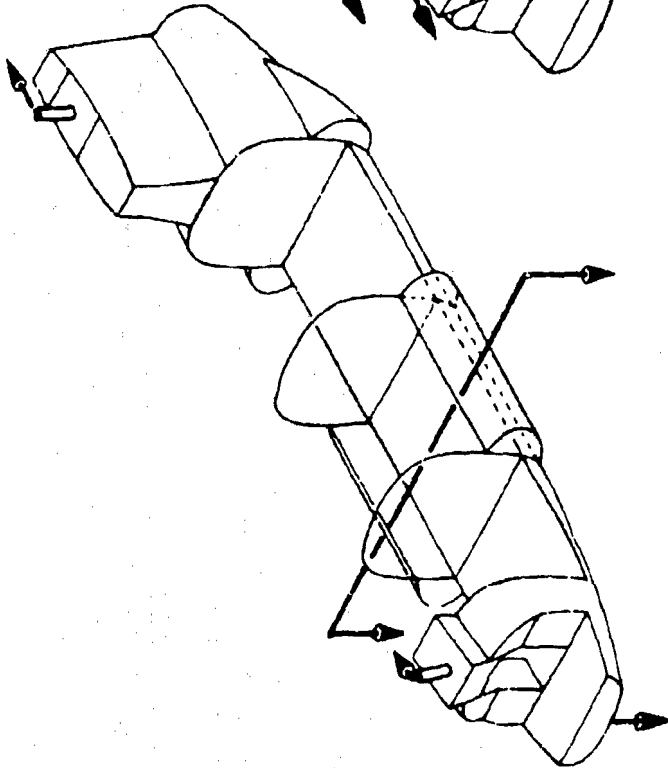

Figure 15. CH-47C AAWS Gun Support Modes

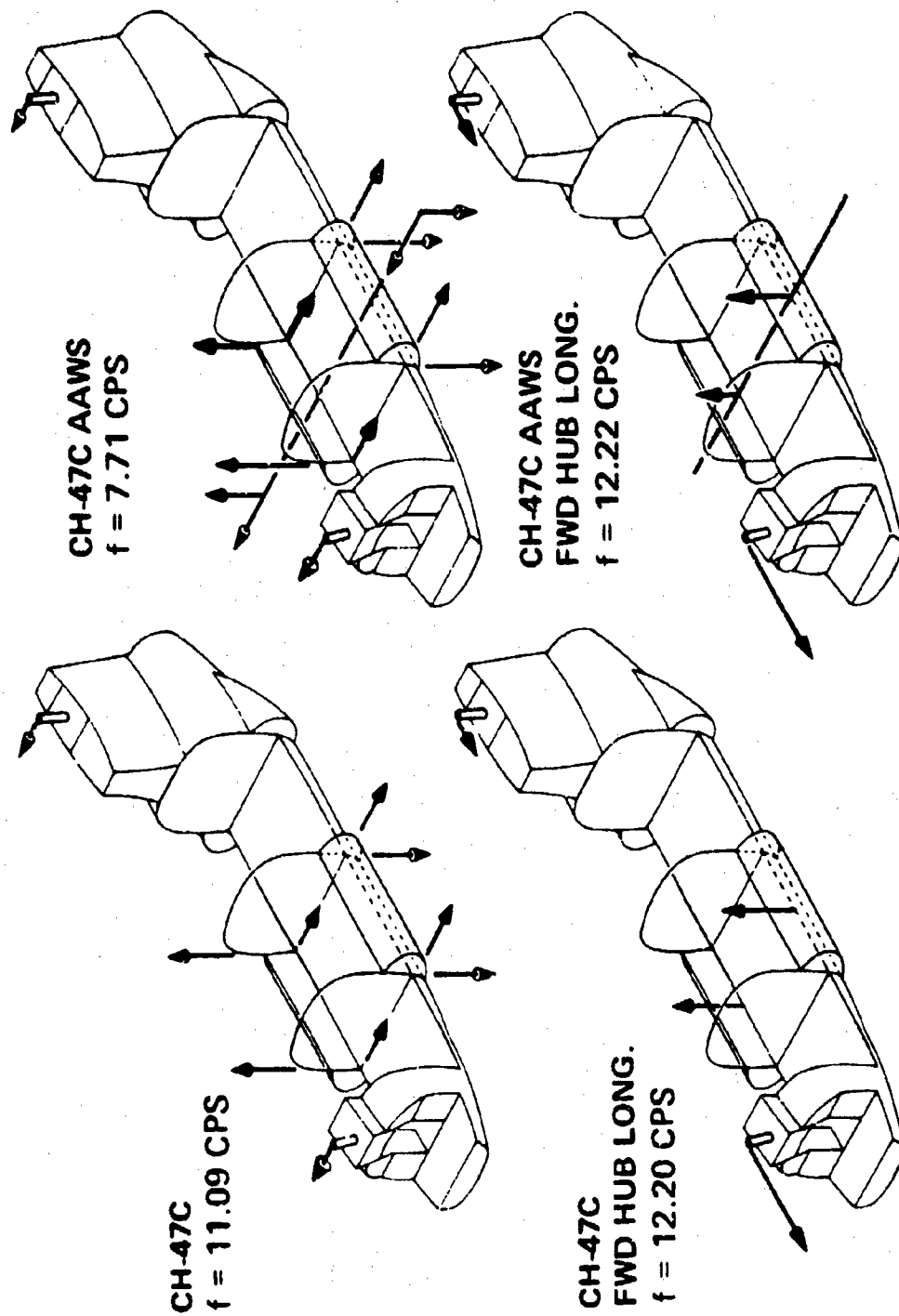

Figure 16. Critical Mode Comparison, CH-47C and CH-47C AAWS

high longitudinal vibration of the gun CG is attributed to force excitation of the second gun mode at 13.96 cps. Howitzer yaw angle displacement resulting from this vibration is approximately 3 mils.

LATERAL VIBRATION

Fuselage

A significant reduction in lateral vibration is apparent for the weapon configuration. In the CH-47C aircraft, the lateral vibration results primarily from excitation of the 11.09-cps mode as shown in Figure 16. For the howitzer-equipped aircraft, the above frequency was reduced to 7.71 cps, resulting in a decrease in response from the 3/rev excitation.

Gun CG

Lateral vibration at the howitzer is predicted to be of the same magnitude as the longitudinal vibration. Similarly, the large lateral vibration can be attributed to excitation of the second gun mode at 13.96 cps.

VERTICAL VIBRATION

Fuselage

Vertical vibration increases in the cabin for the with-howitzer configuration. In the baseline aircraft, vertical response results from excitation in both the 11.09-cps and 12.22-cps modes as shown in Figure 16, but the response phasing is such that cancellation results. However, for the howitzer support aircraft, the 11.09-cps mode is lowered to 7.71 cps, eliminating the response cancellation which results in higher vertical vibration. Cockpit vibration is of similar magnitude, and aft pylon vibration shows a decrease of approximately 25 percent. It is noted that the cockpit vibration levels shown are well above the Military Specification requirements, but these levels are for the aircraft without vibration absorbers. As in the CH-47C aircraft, the installation of the production aircraft absorber configuration would reduce the vertical vibration to the specification levels.

Gun CG

Vertical vibration of the gun is less than 0.1g as a result of the vertical isolation of the first gun mode.

COMPONENT VIBRATION TESTING

All nonstructural components shall be vibration tested in accordance with the Boeing-Vertol component vibration

qualification document for the CH-47C helicopter (114-DY-019-1). This testing is designed to detect weaknesses in design or construction which may cause component failure or malfunction when subjected to the vibration environment of the CH-47C.

HANGING SHAKE TEST

It is recommended that the howitzer/CH-47C helicopter configuration be subjected to a hanging shake test. The purpose of such testing is threefold:

1. To ascertain the location of predicted CH-47C modes with aerial artillery installed.
2. To determine the existence of any structural and artillery mounting resonances and their proximity to CH-47C rotor order excitation.
3. To allow probing of the installation for points of highest stress concentration for optimum location of instrumentation during the flight-test evaluation.

MUZZLE BLAST AND FLASH EFFECTS

Firing of the 105mm howitzer in close proximity to the CH-47C helicopter requires the addition of protective doublers and reinforced hatches in the forward portion of the fuselage shown in Figure 17. Rationale for the design of these reinforcements is described in this section. Detailed calculations involved are presented in the Stress Analysis, Appendix IV. The muzzle blast reinforcements are added to the helicopter as part of the hardpoints provisions kit.

Secondary ignition (flash) of exiting muzzle gases, a phenomenon which can increase blast pressure fourfold, has not influenced the design since it rarely occurs with the 105mm round. With the protection provided, if flash would occur, some damage to the reinforced skin areas would be likely; and some sheet-metal repairs would be required. Development of new rounds, such as the zone 8, could make flash more likely; and some protection from flash may be found to be desirable. A muzzle flash suppressor, such as described in Reference 5, appears to be the best approach to provide flash protection if flash can not be prevented in the development of the round. This device alters the aerothermodynamics of the escape of the gun gases from the muzzle so that flash is prevented. This device would also prevent the occurrence of the visible light produced by the flash phenomenon and would therefore also protect the pilot's vision in night flying.

REINFORCEMENT OF FUSELAGE SKIN

This study has determined that protection against the loads induced by muzzle blast overpressures is required for skin areas adjacent to and forward of the gun muzzles. Figure 17 shows the section of the fuselage for which a skin doubler is required. Design of the doubler is based on calculations of the free-space overpressures for the 30-inch extended-barrel version of the XM204. The Salsbury report (Reference 6) provides the necessary formulae and general blast field solution curves needed for these calculations. In general, the longer barrel allows more complete burning of propellant, providing greater muzzle velocity and a consequent reduction in blast pressure of approximately 20 percent. The free-space overpressure isobars for zone 5 are shown projected on the fuselage of the aircraft in Figure 18. It should be noted that these curves represent only the free-space blast pressures produced by the weapon. Impingement of this pressure wave on the fuselage skin creates a reflected wave with attendant increases in pressure. This phenomenon is well treated by Kinney (Reference 7). From Figure 5 of Reference 8, it was determined that for the range of free-space overpressures and angles of incidence involved, the reflected overpressures range from two to three times that of the incident wave.

REINFORCED PILOTS
ESCAPE HATCH WITH
0.40 THICK PLEXIGLAS
TRANSPARENT AREA

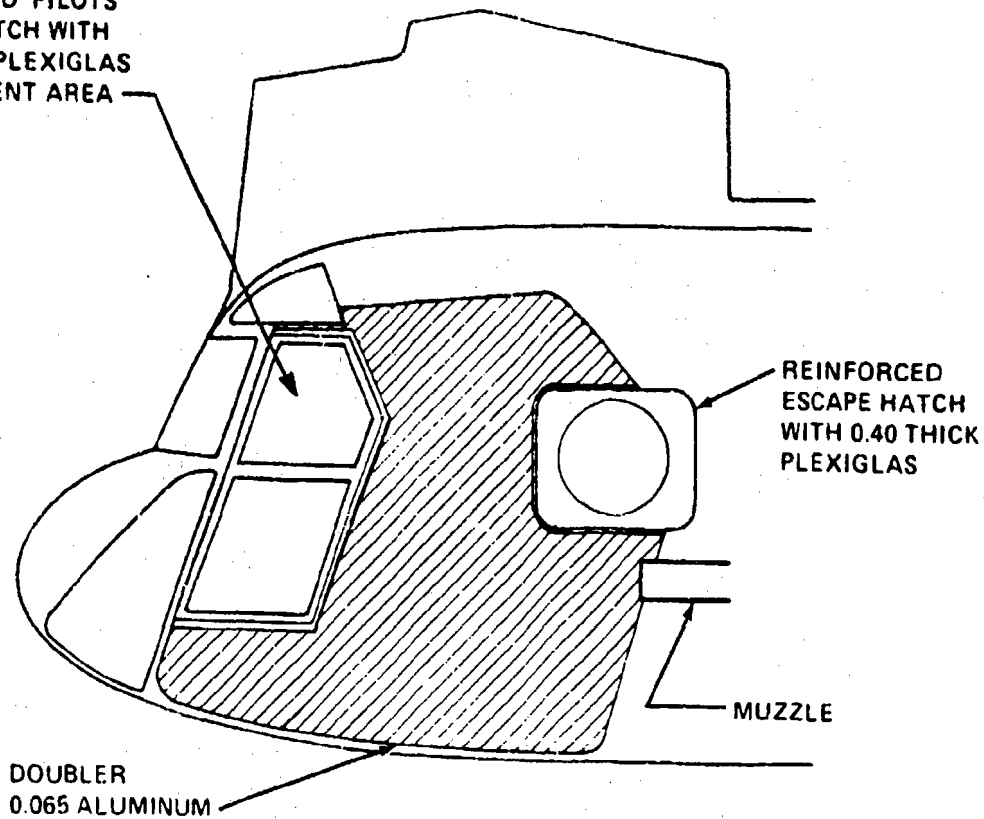

Figure 17. Aluminum Doublers and Reinforced Hatches are Required on Both Sides of Nose of Fuselage

DURATION OF THE OVERPRESSURE IS ESTIMATED TO BE .003 SECONDS.

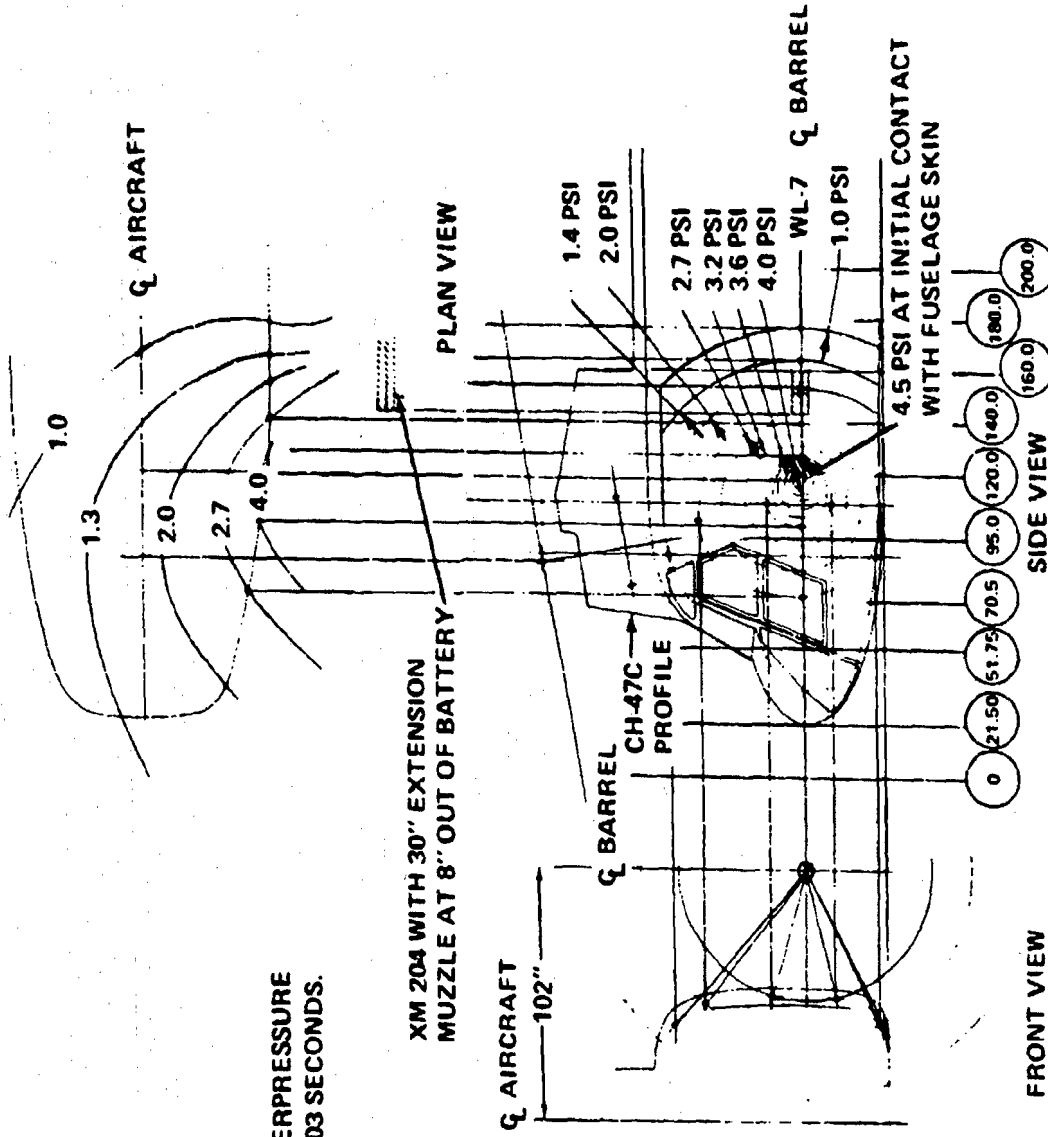

Figure 18. Fuselage Projection of the Free-Space Overpressures Due to Zone 5 Firing of the Extended-Barrel XM204 Howitzer

As skin panels must be protected against an inadvertent firing of a zone 8 round when the weapon is in a forward-firing air-to-ground mode, it was necessary to calculate the free-space and resulting reflected pressures involved. As a new zone 8 round is still under development and the propellant type and weight not yet specified, it was necessary to extrapolate a plot of muzzle velocity to the desired 2,200 ft/sec to determine the associated weight of standard M-1 propellant. Using this approach, an estimated value of 4.5 pounds was determined; and this was used to calculate the peak reflected overpressures for the panels in question.

To determine the thickness of skin necessary to withstand these overpressures, use was made of the blast damage criteria established by Sewell and Kinney (Reference 9). The natural frequency of a critically located panel (shown in Figure 19) was calculated, and a critical time equal to 1/4 of its period was found. From this critical time and the peak overpressures expected (multiplied by a 1.5 factor of safety), a critical impulse was calculated which is the minimum load which, if applied to the panel, would result in damage. As the critical impulse is a function of the panel thickness, speed of sound, and dynamic yield strength, the formula for critical impulse was solved for thickness.

The Appendix IV detail calculations show that for the most critical panel, a reinforcement thickness of .065 inch is required. As a conservative first estimate of the size and weight of the doubler, the .065-inch thickness required for the peak pressure was kept constant over the entire area. In addition, an elastomeric shock absorption material (such as rubber or neoprene) should be sandwiched between the panel and doubler to reduce the vibration and acoustic effects of the blast. Detailed specification of this isolator needs to be addressed in the subsequent program.

STRUCTURAL REINFORCEMENT

Blast loads are taken by the doubler through the fuselage skin and into the fuselage frames. The preliminary design philosophy that all added loads will be taken by reinforcements would require that the fuselage frames be treated. The weight of such reinforcements is of small magnitude and the detail design may show that these reinforcements are not required. Therefore, these structural members have not been treated in this study.

PLEXIGLAS REINFORCEMENT

The Plexiglas areas shown in the Figure 17 sketch must be reinforced to withstand the reflected overpressures produced by the accidental firing of a zone 8 round during air-to-ground

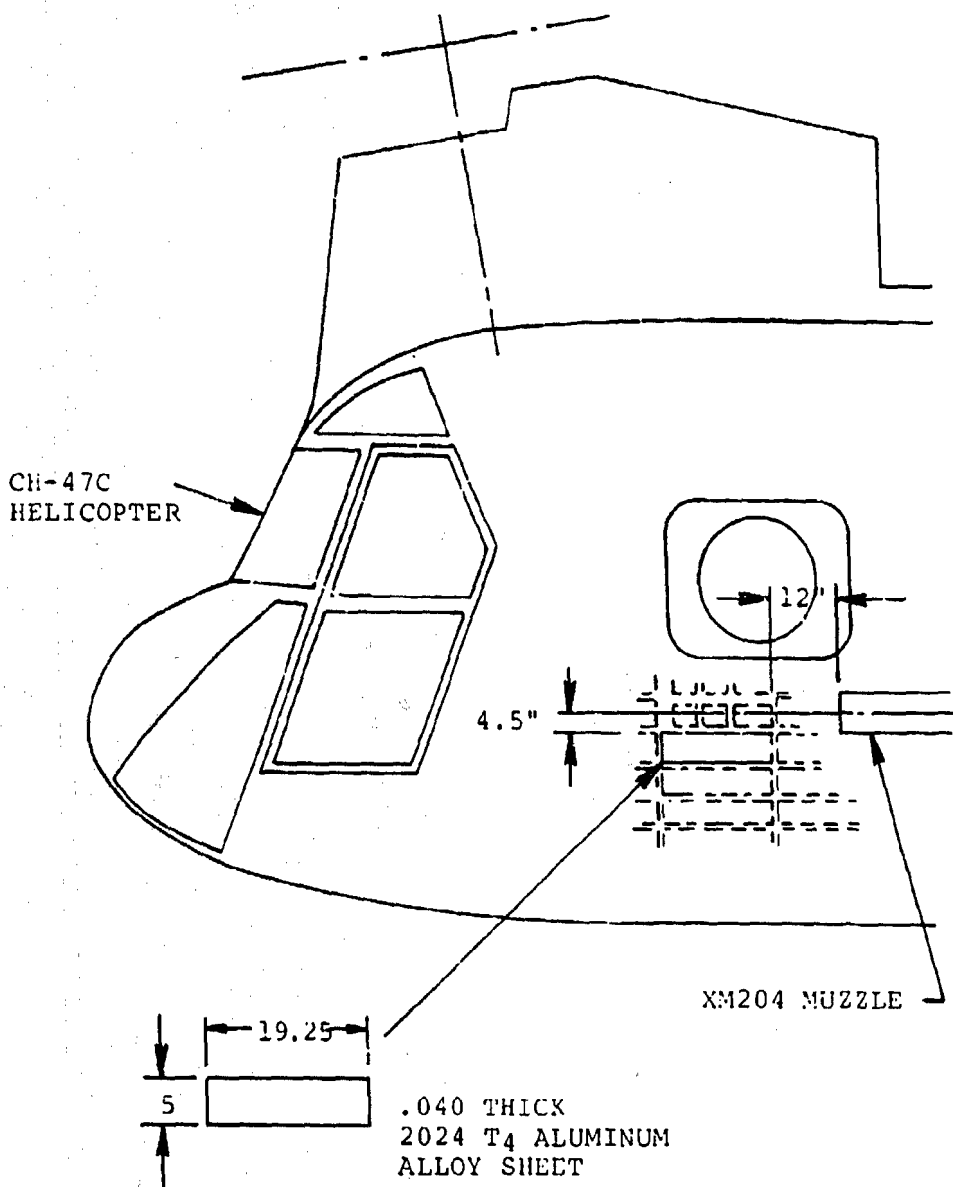

Figure 19. Location of the Most Critical Panel of Fuselage for Muzzle Blast Damage

mode. A detailed dynamic stress analysis of the circular window of the fuselage escape hatch and the pilot escape door is presented in Appendix IV.

The analysis employed used predicted zone 8 incident overpressures to calculate the reflected pressure loads on the Plexiglas. A dynamic yield coefficient of 2.0 was assumed (as contrasted with a coefficient of 3.7 for aluminum); and using the allowables for Plexiglas, the thickness of Plexiglas required was found by a dynamic stress analysis to be 0.4 inch. A similar analysis determined the more distant, but larger, pilot escape door to require the same thickness of Plexiglas. Should a reduction in Plexiglas thickness be desired, reinforcing strips can be employed down the middle of the Plexiglas to help take the added load.

ROTOR BLADE LOADS, STRESSES, AND RESPONSES

Rotor blade stress analyses and aeroelastic calculations of rotor blade loads and responses have been made to determine if rotor system modifications are required to allow repeated firing of the howitzers at zone 5 in the air-to-ground mode. These calculations are not necessary for ground-to-ground attached firing. For air-to-ground firing, the calculated loads are found to be small as compared to the strength of the parts and no modifications are required. Firing zone 5 in this mode will cause no reduction in the fatigue lives of the rotor system components, and considerable margin exists for firing higher charge zones. These analytical results are in good general agreement with the experimental data on the effects of blast on rotor blades reported in Reference 1.

Stresses in the rotor blades have been calculated in a conservative manner by adding the maximum flight maneuver stresses to the stress increment caused by muzzle blast. As shown in Figure 20, the ultimate blade spar stresses are increased less than 10 percent by the blast loads and are well within the ultimate allowables. A similar result is shown in Figure 21 for fatigue stresses. Aeroelastic calculations of rotor control pitch link loads show that the blast load is attenuated by a factor of about 5. The resulting pitch link load will not cause fatigue damage in the control system when superimposed on the flight loads. Details of the blade stress calculations and the margins of safety are given in the Stress Analysis, Appendix IV.

Aeroelastic calculations of rotor loads due to muzzle blast utilized five flapwise bending modes and two torsional response modes with the spanwise distribution of blast pressure shown in Figure 22. This pressure representation is a conservative simplification of the worst case of the interaction of the pressures shown in Figure 23 with the blade. Flap bending

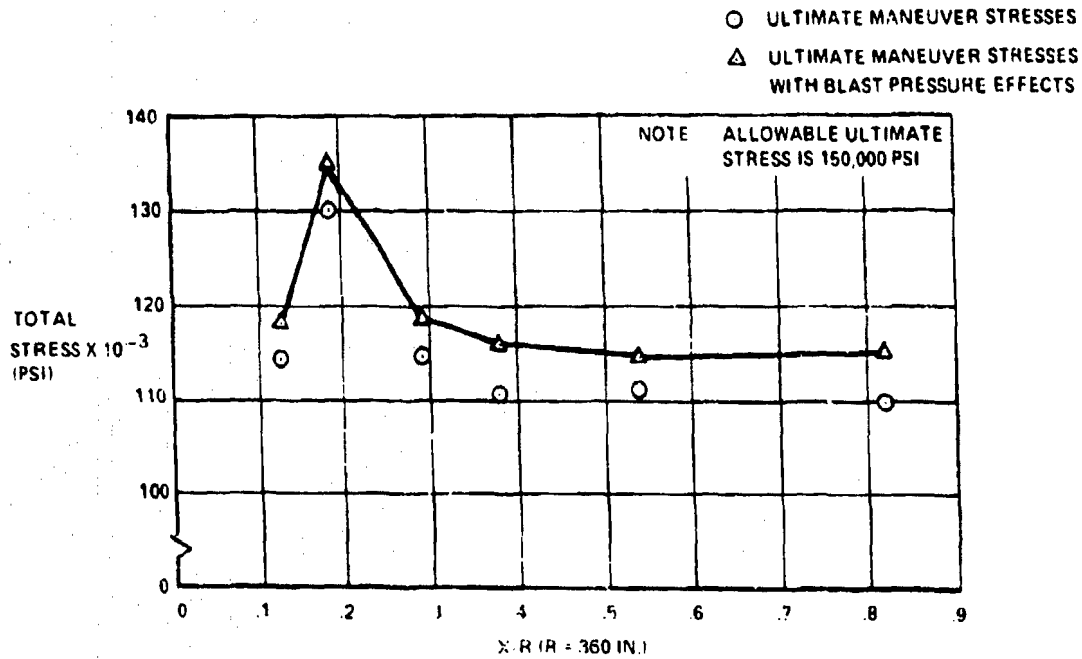

Figure 20. CH-47C Spar Ultimate Maneuver Stresses as Affected by Muzzle Blast Pressure

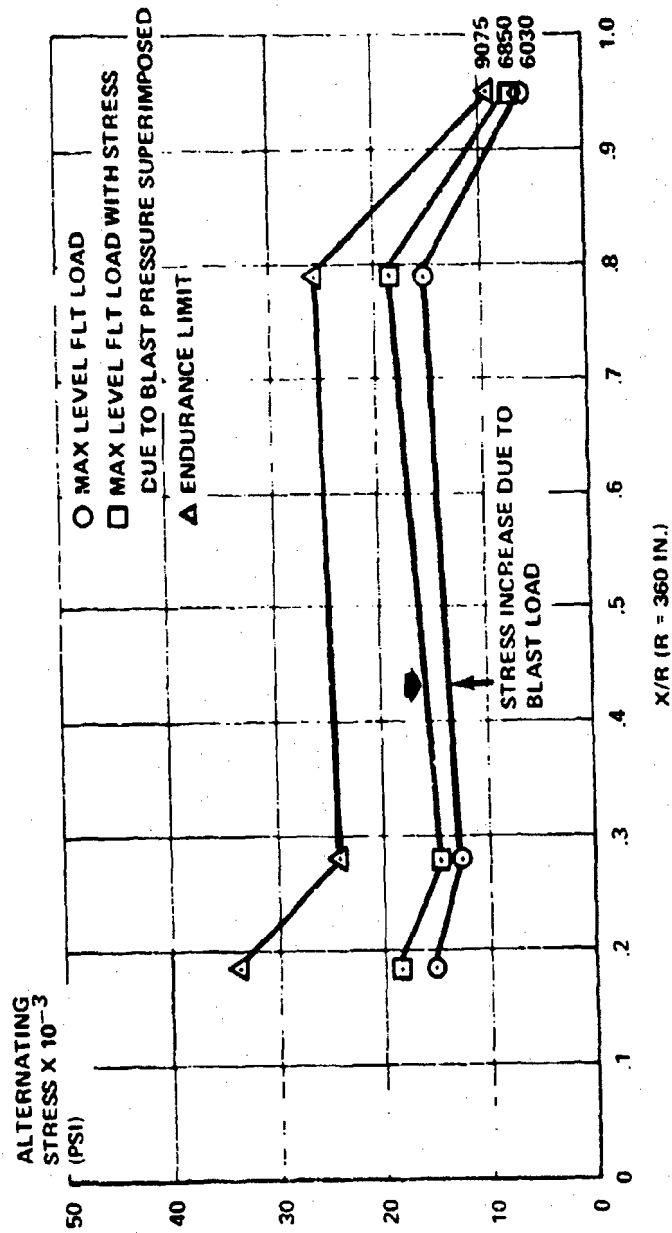

Figure 21. CH-47C Spar Fatigue Stresses as Affected by Blast Pressure

NOTE: PRESSURES SHOWN ARE FOR ZONE 5 CHARGE FROM A STANDARD-BARREL XM204. USE OF A 30-INCH BARREL EXTENSION WOULD REDUCE OVERPRESSURES BY APPROXIMATELY 20 PERCENT.

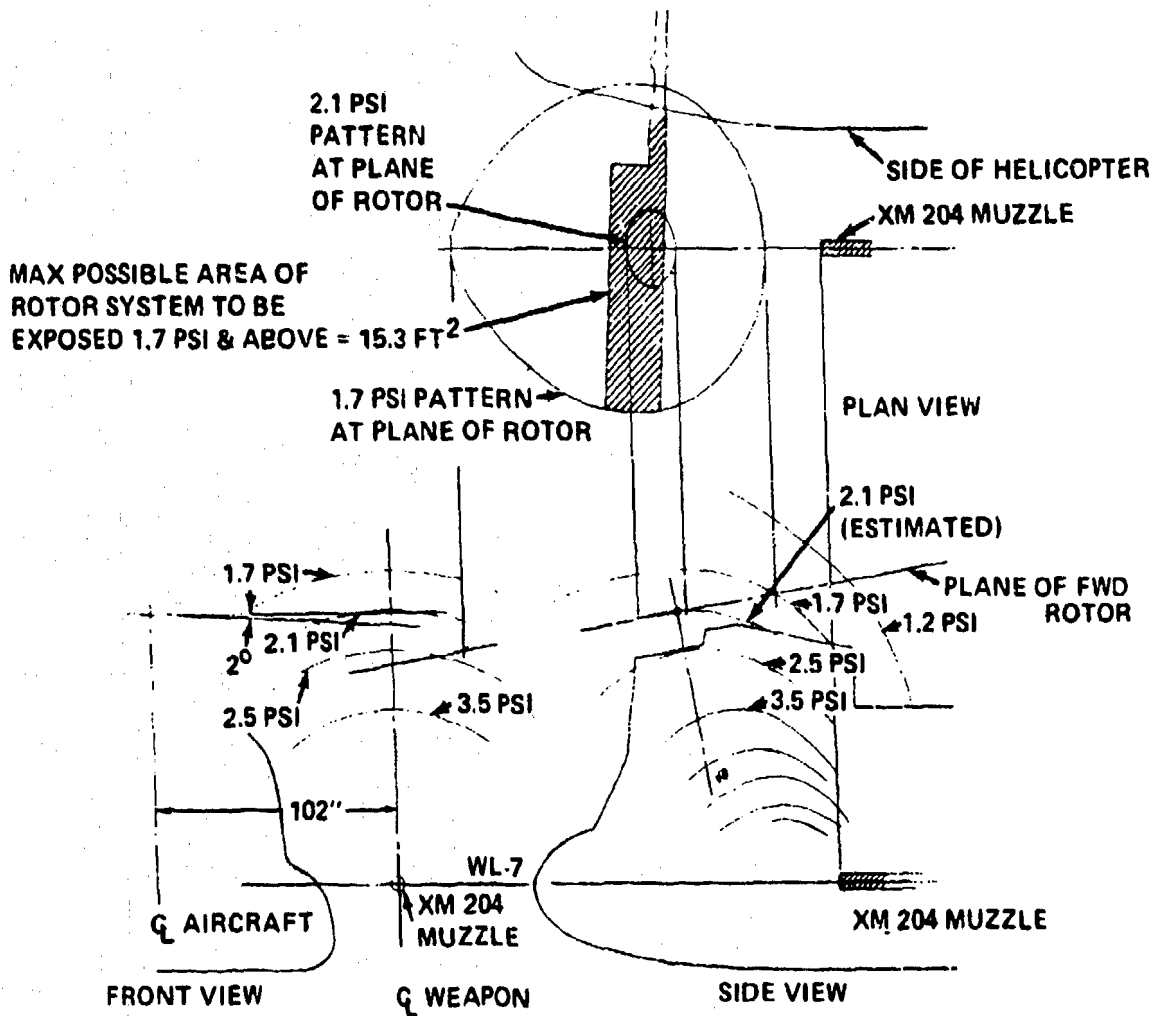

Figure 22. Projection of Overpressure Isobar Pattern on Forward Rotor

NOTES:

1. CH-47C ROTOR BLADE
2. ROTOR SPEED - 230 RPM

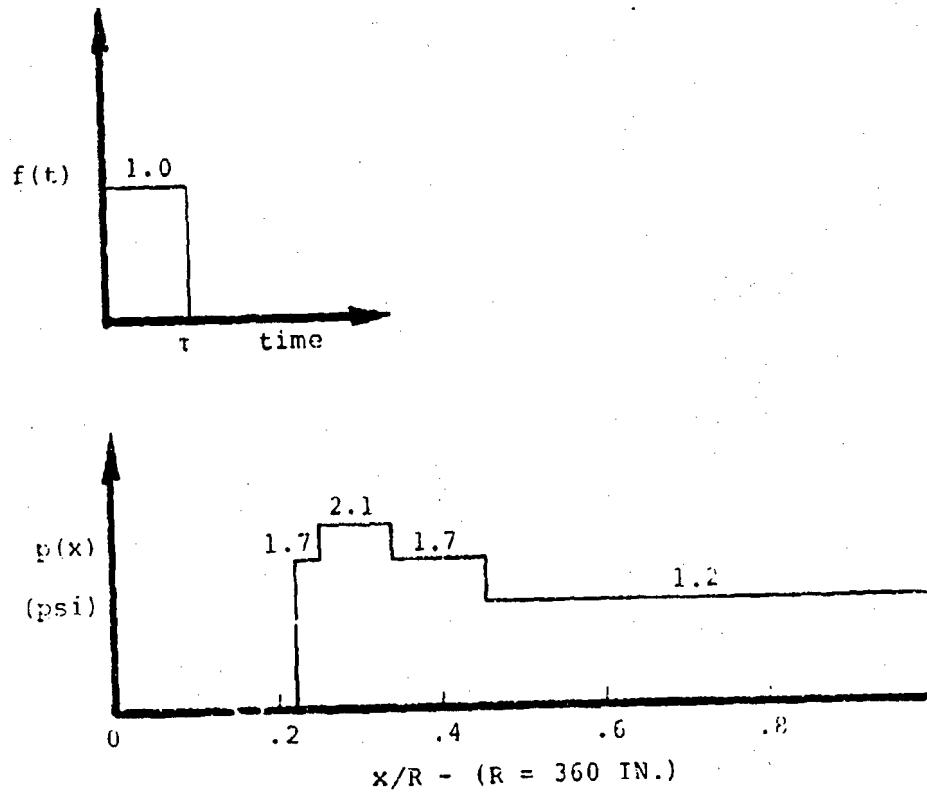

Figure 23. Muzzle Blast Pressure Pulse Representation
Used in Aeroelastic Rotor Loads Calculations

moments, torsional moments, pitch link loads, and flap and torsional deflections are determined for two different pressure pulse durations. The results for $t = .0015$ second correspond to the loads expected on the rotor blade due to the expected pressure blast from the XM204 weapon. The time history of the actual pressure blast starts out at a value of 1.0 at $t = 0$ and goes to zero at $t = .003$ second that is a triangular shaped impulse. To simplify the calculations, the actual triangular shape was replaced by a rectangular pulse of half the duration. This simplification does not change the results since the ratio of the impulse duration to the natural periods of the flap and torsion natural frequencies is small so that the shape of the pulse is inconsequential and the blade response depends only on the impulse area. Results shown for $t = .003$ second are included to show how the blade response would increase if the pressure load impulse were doubled.

The load calculations were made using generalized coordinate theory to obtain the linearized equations of motion and generalized forces. The generalized flap and torsion loads being

$$Q_{Fn} = f(t) \int c p(x) Z_n(x) dx$$

$$Q_{Tn} = f(t) \int c^2 p(x) (1/2 - PA) \theta_n(x) dx$$

where

$f(t)$ = the time function applied to the rotor blade

$p(x)$ = spanwise distribution of blade loading due to pressure blast

c = blade chord

$Z_n(x)$ = flap bending deflection mode shape

$\theta_n(x)$ = torsional deflection mode shape

Values were calculated for the mass, spring, and damping matrices as well as for the generalized forces. Utilizing Boeing Computer Program L-33, the flap response and torsional response of the blade were determined. Blade flapwise and chordwise bending and torsional moment distributions were calculated from these responses.

Response of the blade to blast results in the flapwise moment distribution shown in Figure 24. The peak moment of about 8,800 in.-lb at about 15 percent radius is approximately 1/8 of the normal vibratory bending moment caused by flight at 130 knots. This change is a negligible increase in load. As shown in Figure 25, the predominant response of the blades to the blast results from the rigid body rotation of the blades about

NOTES:

- 1. CH-47C ROTOR BLADE
- 2. ROTOR SPEED - 230 RPM

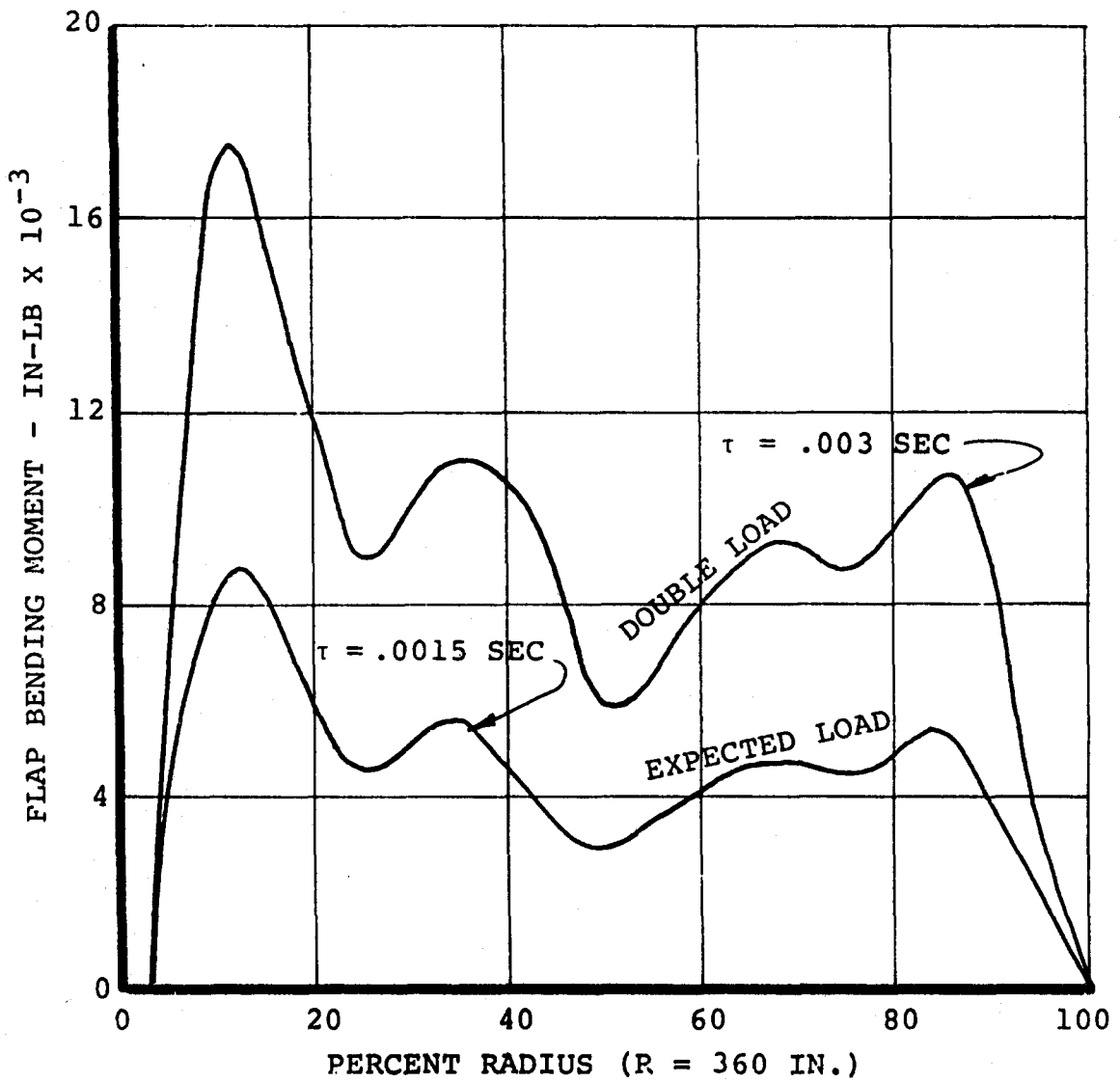

Figure 24. Flapwise Bending of Blades Due to Zone 5 Muzzle Blast

NOTES:

1. CH-47C ROTOR BLADE
2. ROTOR SPEED - 230 RPM
3. ZONE 5, DOUBLE LOAD

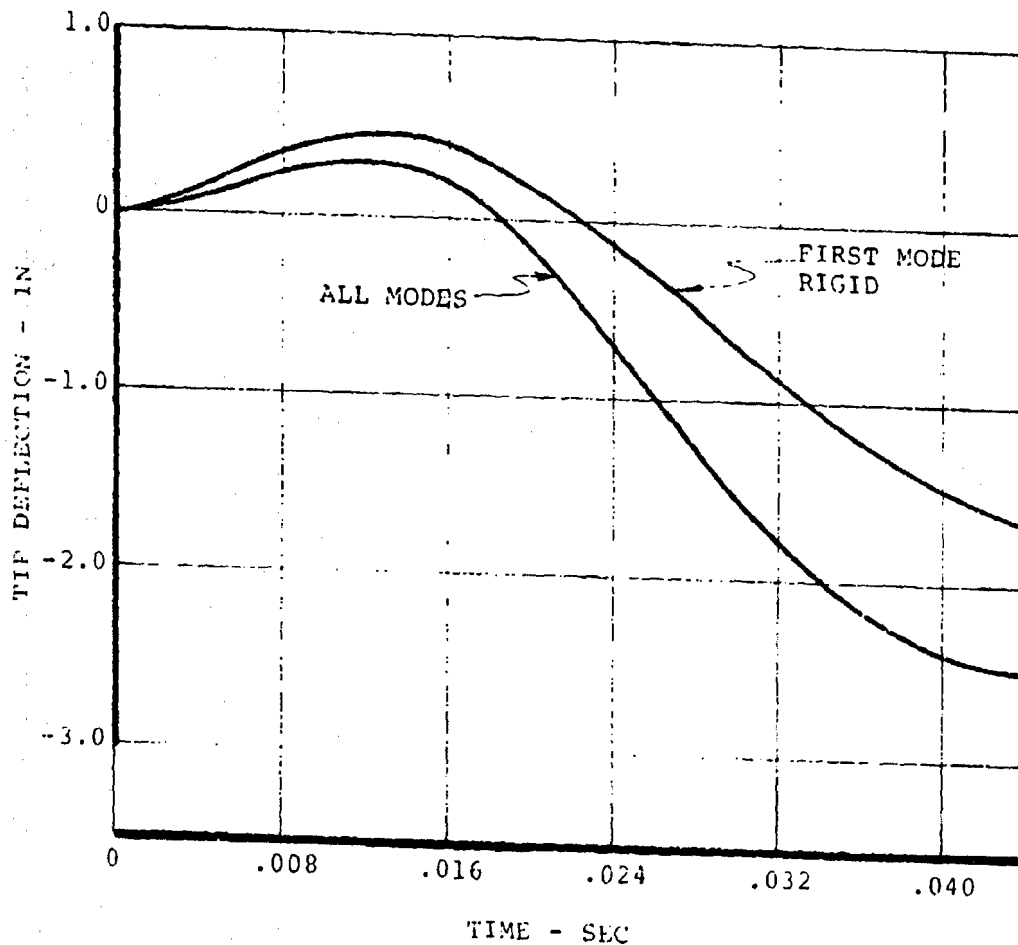

Figure 25. Flapwise Excursion of the Blades is Predominantly Rigid-Body Motion

the flapping hinges. Elastic bending of the blades causes only about 1/3 of the flapwise excursion.

The torsional response of the blade due to the blast, shown in Figure 26, results in the loads in the control system shown in Figure 27. This load was initially of concern since the static load, as shown on the figure, is 5,400 pounds; however, the dynamic calculations show that due to the short duration of the impulse, this load is attenuated by a factor of about 5. The 1,200-pound control load predicted is small as compared to the fatigue strength of the control system. Dynamic response of the blade tip twisting to the expected muzzle blast load is shown in Figure 28 to have a double amplitude of about 1.7 degrees. This response is of a high frequency, about 9/rev, and contributes to the blade flap bending response, but it has no other significance.

NOTES:

1. CH-47C ROTOR BLADE
2. ROTOR SPEED - 230 RPM

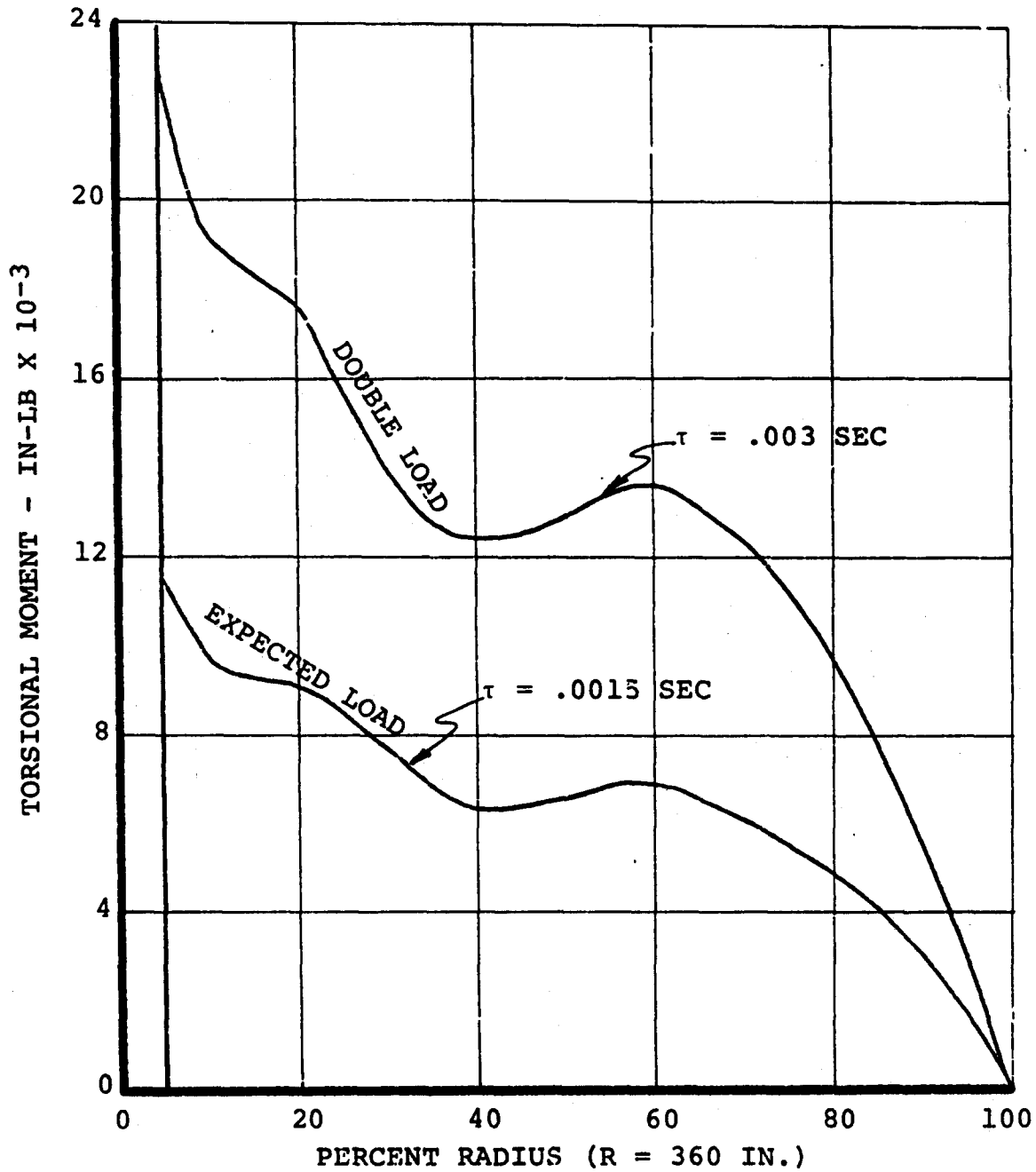

Figure 26. Torsional Moment Distribution Due to Blast

NOTES:

- 1. CH-47C ROTOR BLADE
- 2. ROTOR SPEED - 230 RPM

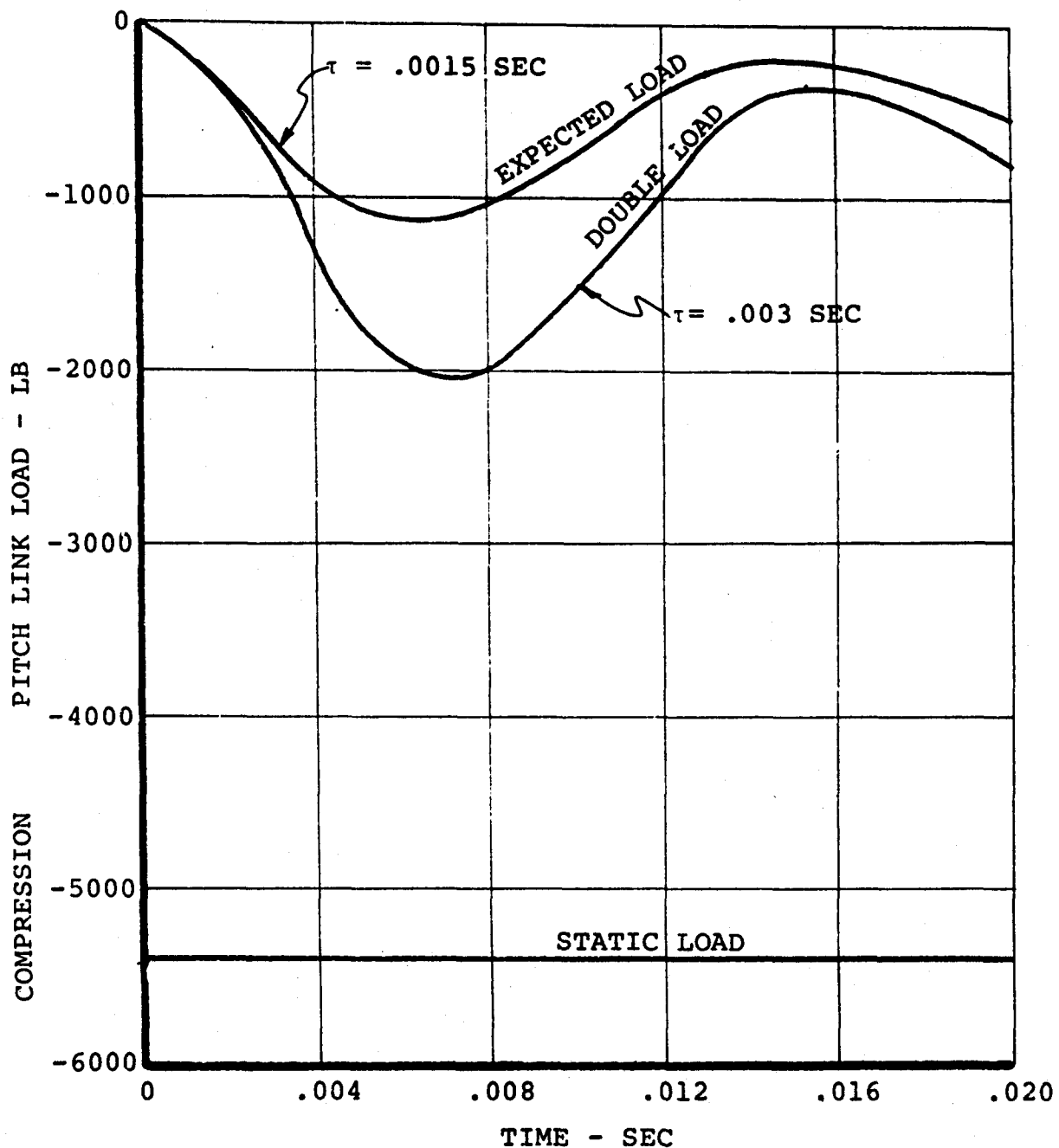

Figure 27. Rotor Control Pitch Link Loads Due to Muzzle Blast

NOTES:

1. CH-47C ROTOR BLADE
2. ROTOR SPEED - 230 RPM
3. ZONE 5, EXPECTED LOAD

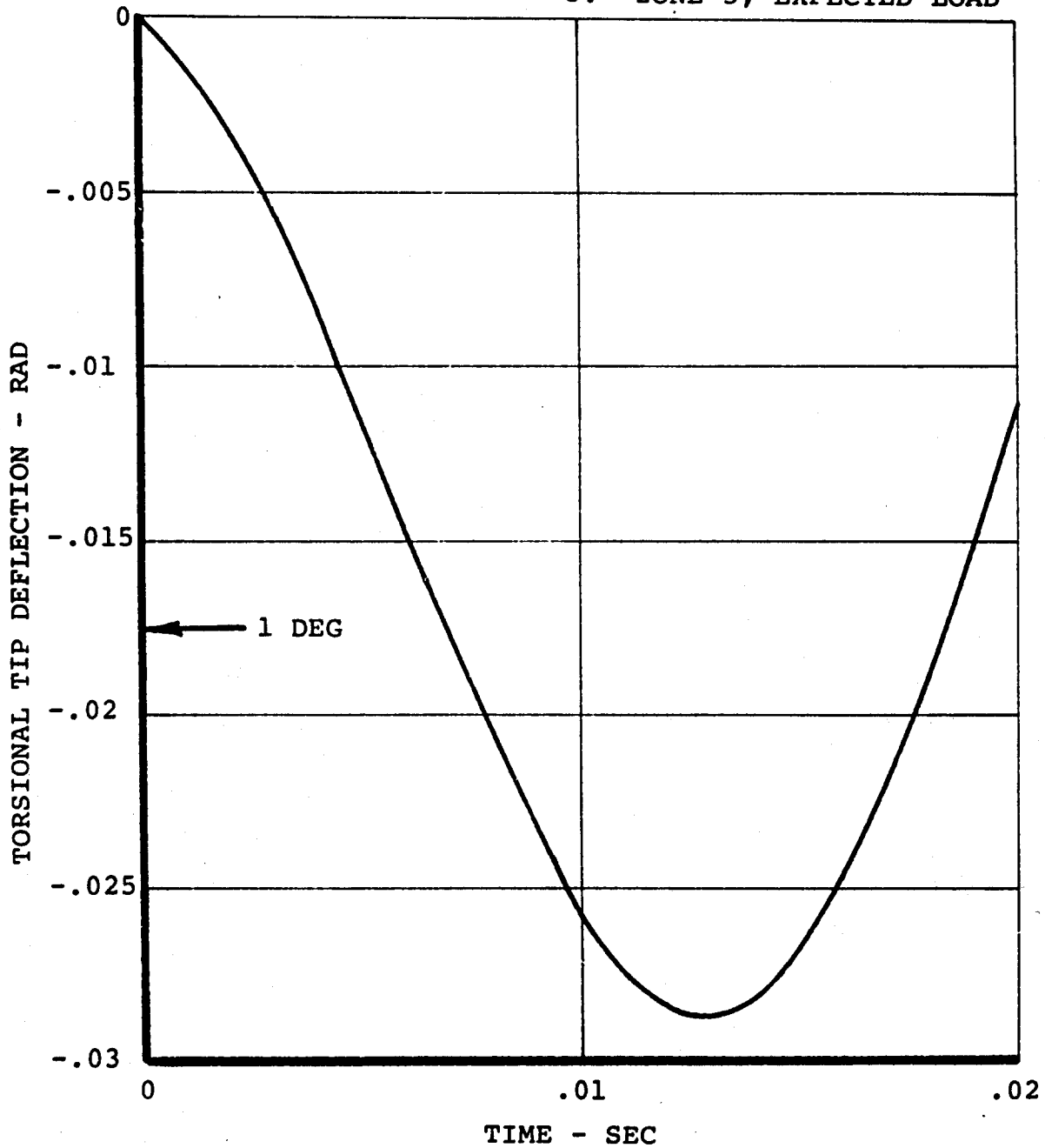

Figure 28. Blade Tip Twisting Deflection Due to Muzzle Blast

DYNAMIC RESPONSES OF AIRCRAFT TO WEAPON FIRING

Dynamic calculations have been made to determine the need for additional reinforcements and protection of the aircraft from recoil and muzzle blast effects when the time history of the loading is considered. Blast and recoil loads are both impulses. Blast has an almost instantaneous pressure rise time and the pressure decays in a nearly-triangular manner back to ambient in about .002 seconds. Recoil of the XM204 soft howitzer is a rectangular pulse with a duration of about .4 second. All the dynamic systems of the helicopter will be perturbed by the firing blast and recoil impulses, but the significant responses will occur only in those systems with sufficiently large natural frequencies that the load is not attenuated. This is illustrated in Figure 29 which shows that for the blast and recoil pulses, those dynamic systems with natural frequencies greater than 250 and 0.5 Hz, respectively, must be considered. The 250 Hz limit for blast loads is so high that most of the helicopters' dynamic systems will attenuate blast loads. Structural panel natural frequencies are greater than 250 Hz; and therefore, the hydraulic response of these panels has been included in the stress analyses involved. Systems with lower natural frequencies (for example, the rotor blade response to blast which was presented in the previous section) show little dynamic response to blast as a result of the attenuation. This is in contrast to recoil loads which will excite almost all of the dynamic responses of the helicopter. Responses above the 0.5 Hz limit for recoil loads include almost all the elastic responses and most of the rigid body responses including the flying qualities modes. Fortunately, all these responses appear to be of such low magnitude with the soft recoil howitzer in the design configuration, no load protection or structural reinforcements are required. Results of the various response analyses performed are discussed in further detail in this section.

DYNAMIC RESPONSES TO MUZZLE BLAST

The only significant responses of the helicopter to muzzle blast will be:

- Rotor blade dynamic motions and elastic deflections
- Fuselage nose panel elastic deflection
- Fuselage frame elastic deflections

The dynamic responses of the blades and panels are discussed in the previous section and in Appendixes III and VII. Fuselage frame dynamic responses were studied in Reference 1, and this methodology should be applied when the detail design

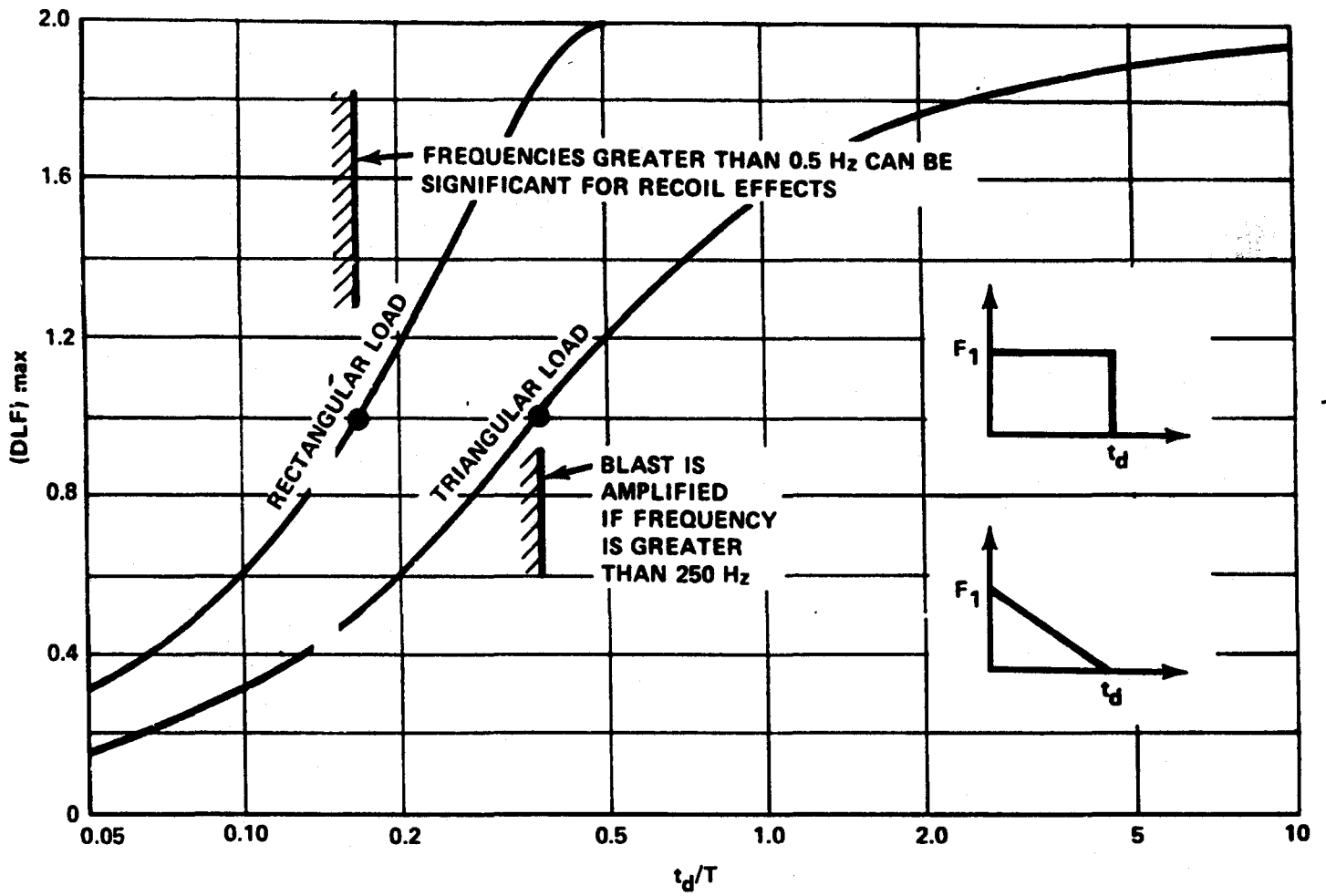

Figure 29. Single-Degree-of-Freedom Analysis Illustrates Significant Modes of Response

of the aerial artillery installation is executed. Some frame reinforcement may be necessary, depending on how well the skin doubler spreads the load into the frames. The weight involved in such reinforcements is small so the preliminary design of these items was not attempted in this study.

AIRCRAFT RESPONSE TO RECOIL LOADS

The motions of the helicopter due to the recoil force from firing one of the howitzers in the air-to-ground mode have been calculated. These motions are generally shown to be less than two-degree excursions if the pilot made no control corrections. Control motions required to completely negate the recoil effects involve displacements of less than one inch which are held for about 1/4 second. These control inputs could easily be accomplished by the pilot; or for more rapid corrections, the inputs could be made automatically through the stability augmentation system. This analysis shows that from helicopter motion considerations, the added complication of adding impulse generators on the weapons is not warranted.

Attitude time histories were obtained by the digital solution of the helicopter equations of motion to estimate the transient response characteristics to arbitrary time variations in specified forcing functions. The primary forcing function in this instance was the howitzer recoil which had the impulse and duration as a function of firing zone shown below.

<u>Zone</u>	<u>Impulse (lb-sec)</u>	<u>Duration at 5,000 Pounds (sec)</u>
1	721	.144
2	782	.156
3	870	.174
4	973	.195
5	1,133	.226
6	1,370	.274
7	1,751	.350
8	2,266	.454

Yaw and roll responses were of primary interest and were examined as a function of parametric variations in aircraft gross weight, center of gravity, airspeed, firing zone, and restoring pedal displacements.

In general, the data indicate that the yaw and roll attitude displacements from trim following asymmetric firing of one of the howitzers are relatively small. The time histories shown in Figures 30 through 33 indicate that above airspeeds of 60 knots, the motion is adequately damped and maximum yaw excursions of 1.0 to 1.3 degrees from trim and experienced. Roll attitude deviations from trim are less than 1.0 degree.

Aircraft configuration (i.e., gross weight and CG variation) has little influence on resulting attitude motion. Differences of less than 0.3 degree are shown in Figures 32 and 33 for the entire weight and CG envelope tested.

Figure 30 shows that low damping and stability at hover and low speeds (below 60 knots) allows yaw attitude deviations from trim of 4.0 degrees within three seconds. The associated yaw rates experienced were on the order of 1.0 to 2.0 deg/sec, which is extremely low.

The effects of varying the firing zone (impulse time) were investigated, and the data relative to the minimum and maximum zones is presented in Figure 31. A maximum difference of 1.5 degrees exists between yaw responses to zone 1 and zone 8 firings. The maximum displacement from trim was 2.1 degrees for the zone 8 firing.

One method of reducing the aircraft displacement from trim due to gun recoil is to introduce simultaneously with the firing impulse an equal and opposite control impulse. This method was investigated and the results are presented in Figure 34. The .75-inch equivalent pedal input reduced the yaw motion to approximately 0.1 degree.

ELASTIC RESPONSE OF FUSELAGE TO RECOIL LOADS

A generalized coordinate analysis was made to determine the response of the fuselage to the recoil impulse from the XM204. The impulse size used was 2,000 lb-sec with a duration of approximately .4 second. The analysis considers nine elastic fuselage mode shapes coupled with the howitzer in its mounted position. The summation of all nine modal contributions to the fuselage elastic deflection response in the longitudinal, lateral, and vertical directions is determined at several points on the fuselage. Shown in Figure 35 is the response at the cockpit in three directions. A maximum acceleration of .14 g's in the vertical direction at the cockpit was determined from this displacement response.

SUSTAINED FIRE EFFECTS

Sustained firing of the weapon at firing rates up to 30 rounds per minute will not give loads of greater magnitude than a

single firing. A single firing of the weapon can cause a maximum dynamic amplification factor of two since the modal frequencies are relatively short. However, for the case of sustained firing, the impulse loads occur periodically which give rise to many harmonics of forcing. Three items become important: (1) do any of the firing harmonics come close or coincide with an aircraft modal frequency; (2) do the modes which have modal frequencies close to the firing harmonics have large modal deflections at the location of the weapon positions in the aircraft; and (3) how long does the sustained firing last. If a combination of items (1) and (2) does exist, that is, a harmonic of the sustained firing load vs. time waveform is close to the natural frequency of an aircraft mode and that mode does have large modal deflections at the weapon location, a large dynamic amplification of the aircraft response will occur. With typical structural damping of aircraft structures, the maximum dynamic amplification will be approximately 17. However, the dynamic amplification factor is offset by the fact that the magnitude of the harmonic component near the resonant frequency will be much smaller than the magnitude of the impulse load. For example, a rectangular impulse load of magnitude 5,000 pounds lasting 0.4 second fired every two seconds contains a 6-cps frequency force magnitude of 290 pounds which is a factor of 1/18 the impulse magnitude. Also, even if this is the case, the maximum dynamic amplification will not be attained immediately; some length of time will be required to reach this. Item (3), the time of sustained firing, is therefore an important consideration.

NOTE: ASSUMES RIGHT HOWITZER FIRES ONE ROUND AND PILOT MAKES NO CONTROL CORRECTIONS

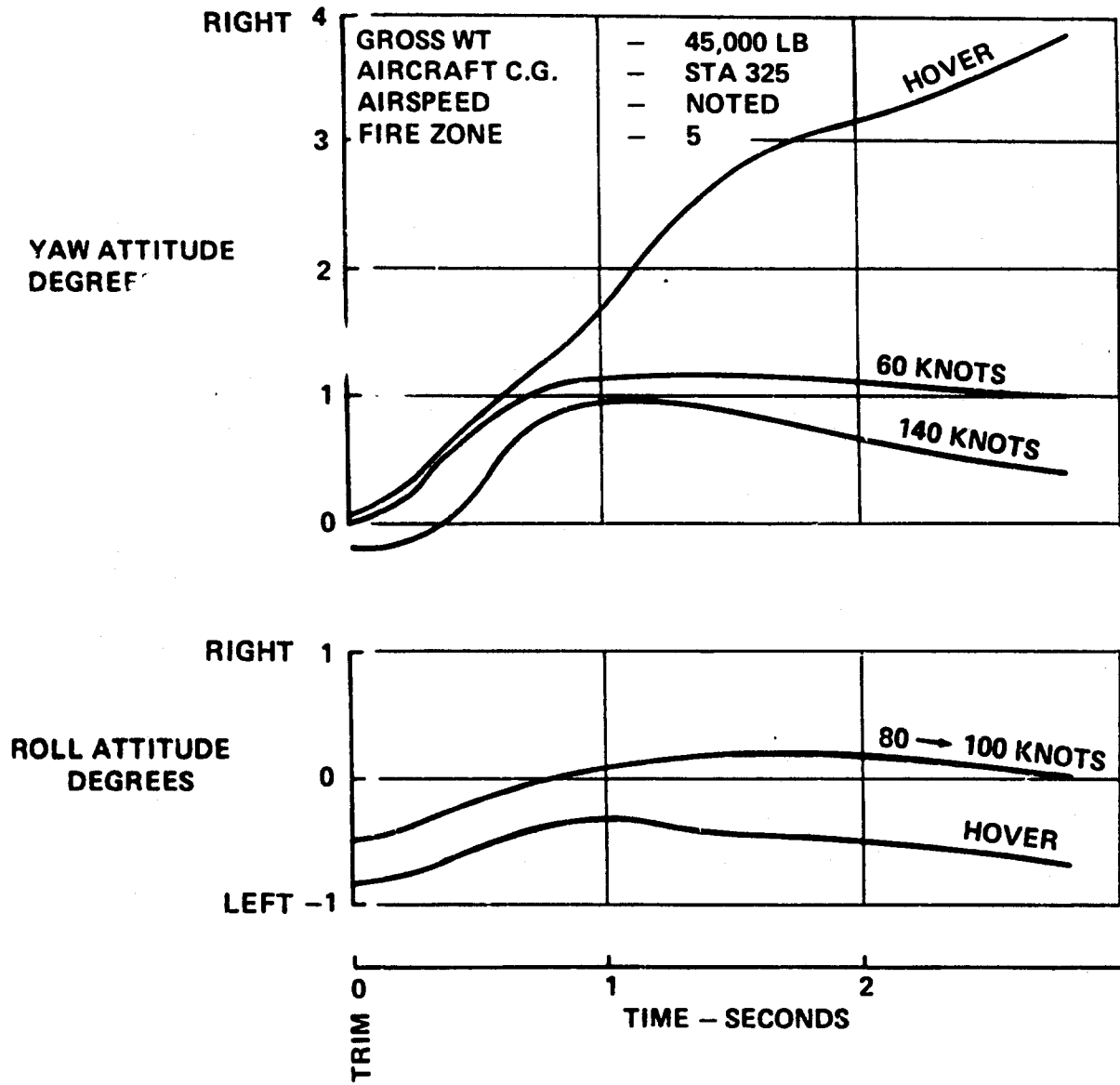

Figure 30. Responses to Recoil Are Reduced With Increased Airspeed

NOTE: ASSUMES RIGHT HOWITZER FIRES ONE ROUND AND PILOT MAKES NO CONTROL CORRECTIONS

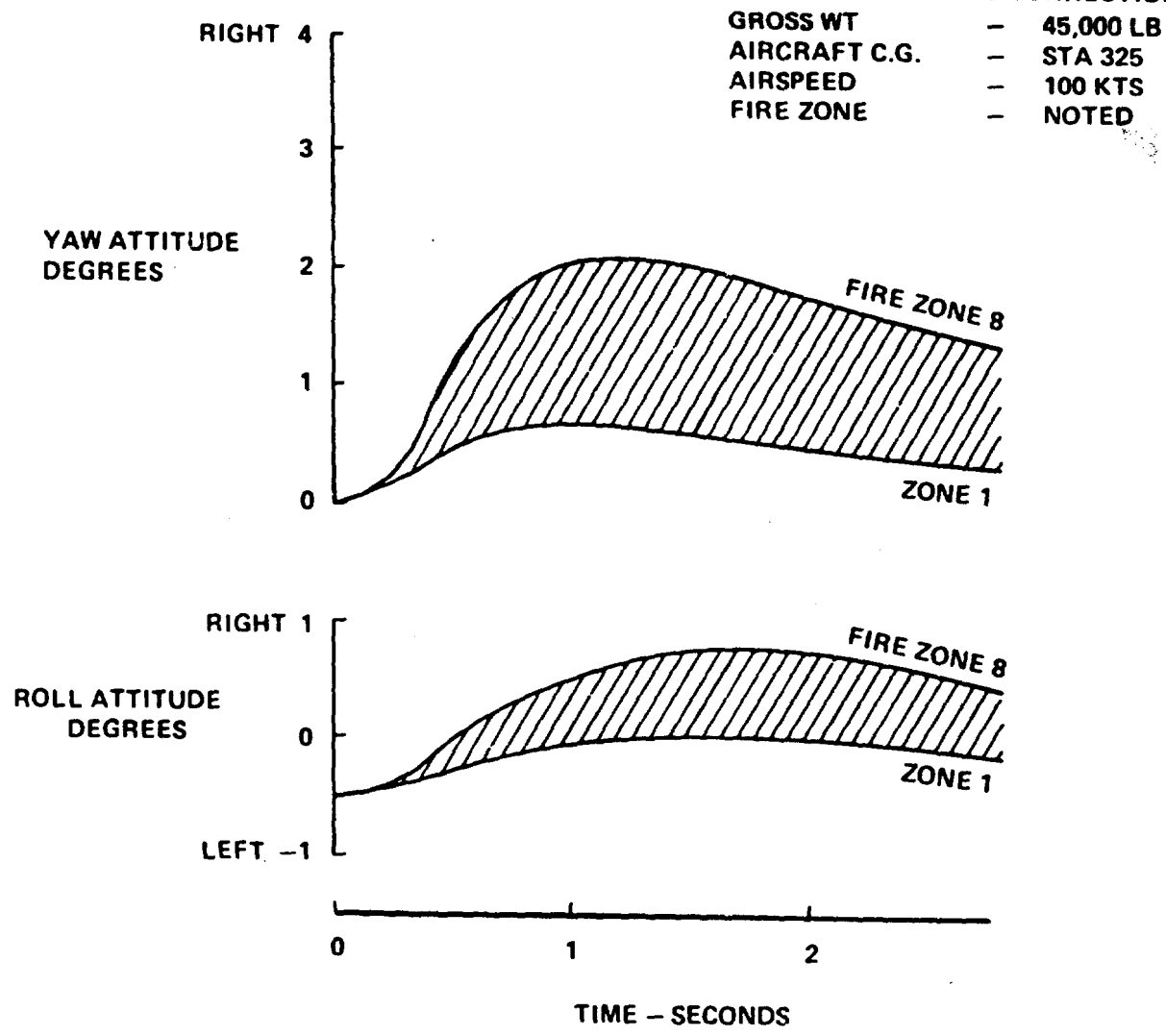

Figure 31. Responses to Recoil Increase With Increased Firing Zone

NOTE: ASSUMES RIGHT HOWITZER FIRES ONE ROUND AND PILOT MAKES NO CONTROL CORRECTIONS

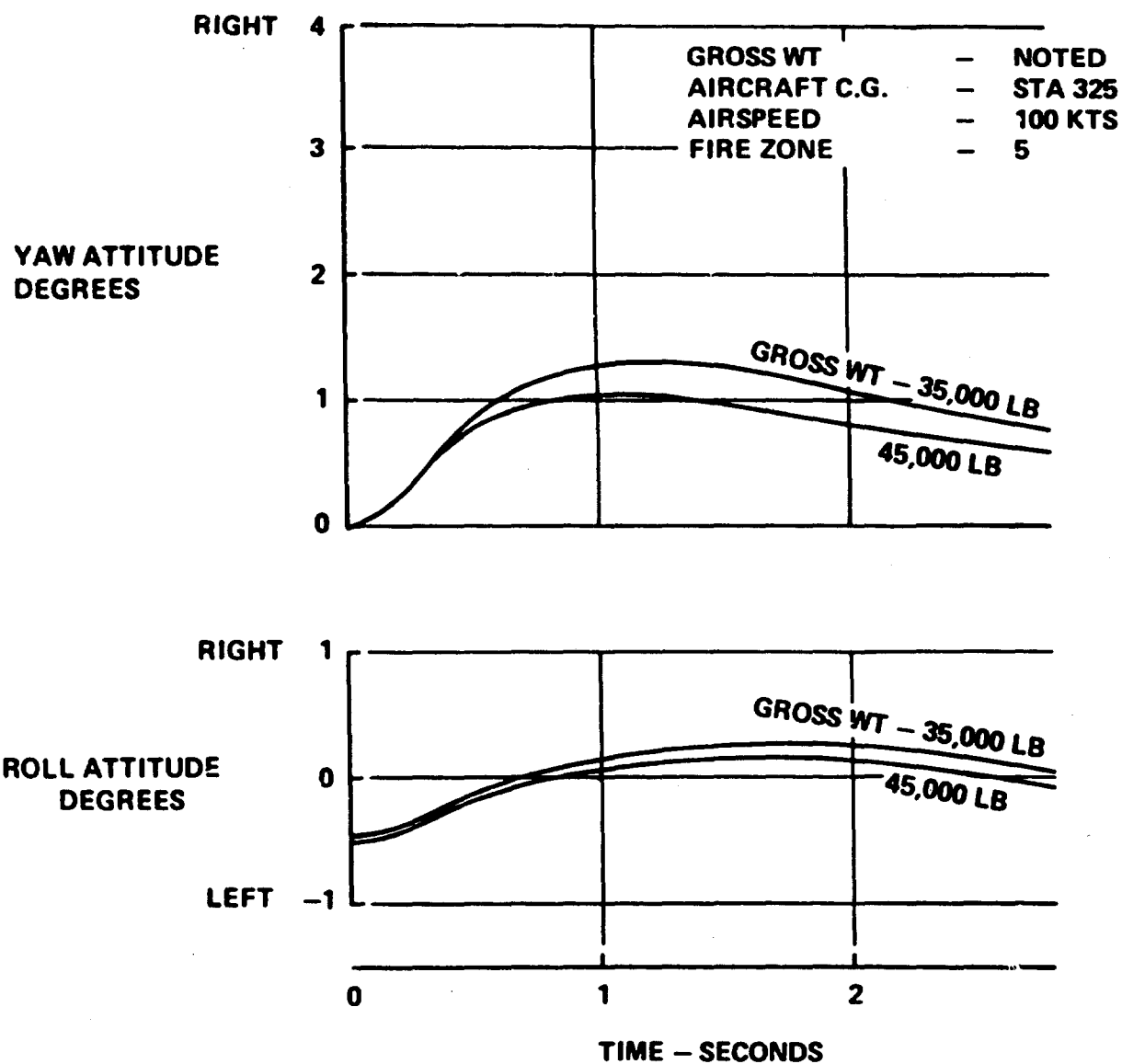

Figure 32. Helicopter Responses to Recoil Do Not Vary Much With Gross Weight

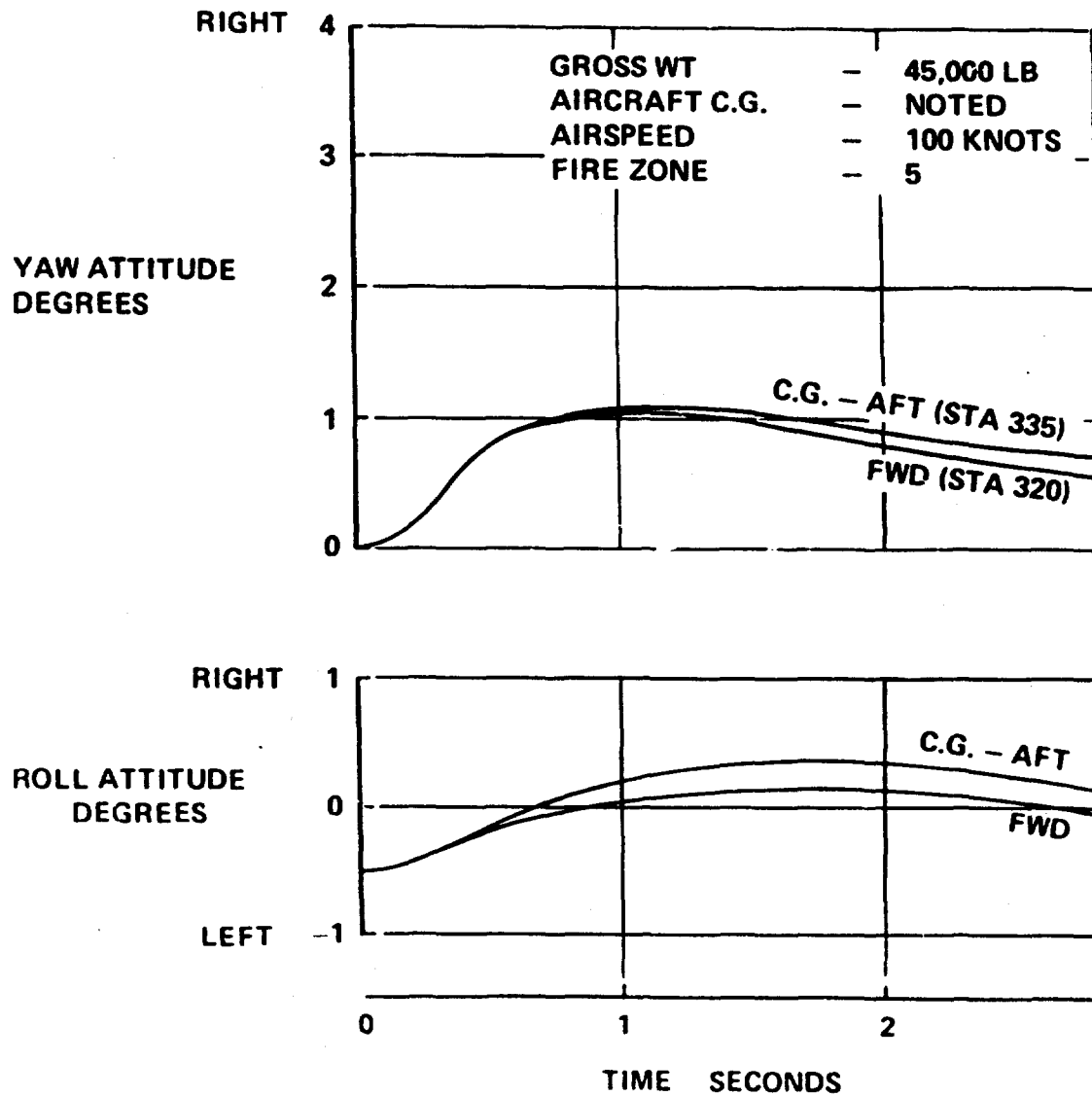

Figure 33. CG Variations Have Small Effect on Responses to Recoil

NOTE: ASSUMES RIGHT HOWITZER FIRES ONE ROUND

GROSS WT	-	45,000 LB
AIRCRAFT C.G.	-	STA 325
AIRSPED	-	100 KNOTS
FIRE ZONE	-	5

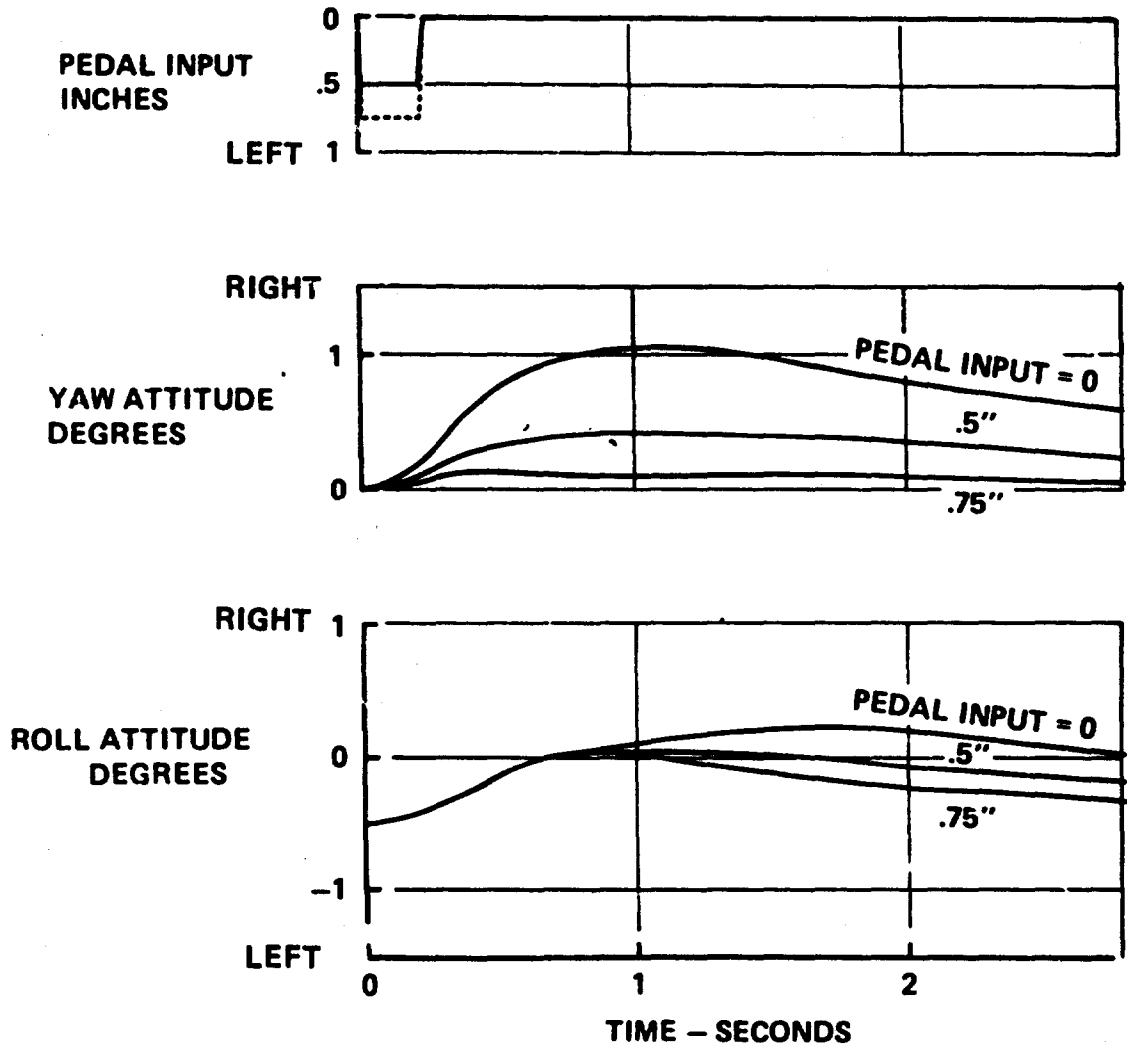

Figure 34. Small Control Inputs Can Correct the Effects of Recoil

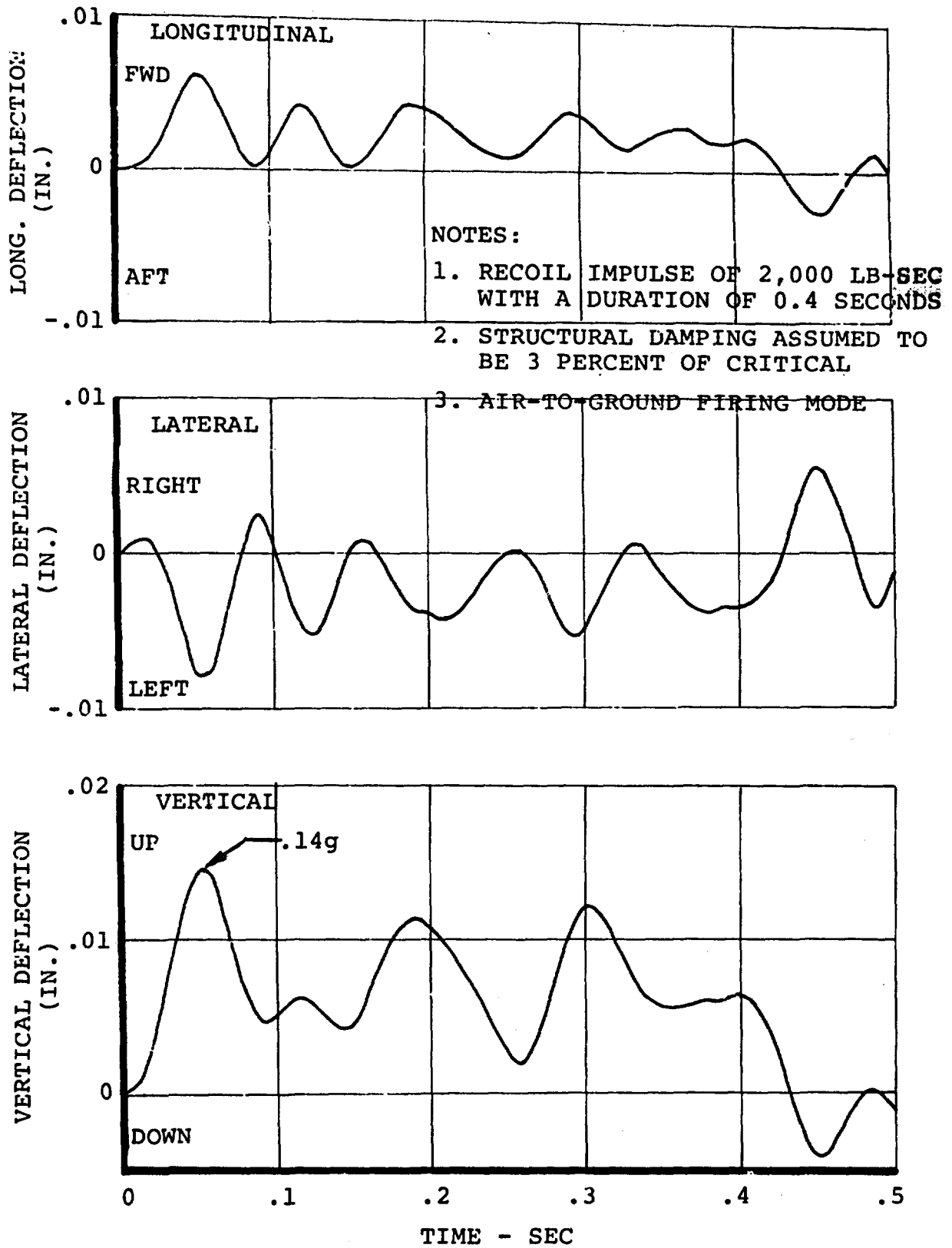

Figure 35. Deflection Response of the Cockpit Due to the Recoil Load from a Single Firing of One Weapon

EFFECTS OF GUN GAS INGESTION AND
MUZZLE BLAST ON ENGINES

The impact on the helicopter engines of ingesting the hot gun gases and the overpressures emanating from the aerial artillery muzzle blast has been evaluated. In addition, for air-to-ground firing, the possible effect of impulse generator exhaust on the engine inlet flow was also assessed. The latter would appear to be potentially a more severe problem due to the proximity of the impulse generator and the engine inlet, but neither the hot gases from firing nor the impulse generator exhaust was found to pose a serious ingestion problem for the engines.

AIR-TO-GROUND FIRING

The rate of discharge of expended propellant and the magnitude of the rotor downwash were determined to assess the severity of the hot gas ingestion problem when firing from the hovering helicopter. At design gross weight, the disc loading of the 60-foot-diameter CH-47C rotor is 5.82 psf, and the corresponding rotor downwash is 15,100 lb/sec. For the 105mm howitzer, the following assumptions were made:

- Zone 7 propellant charge, 2.82 lb (conservative calculation)
- Conversion factor, propellant to hot gas - 95 percent
- Firing rate - 100 rounds/minute

The hot gas resulting from muzzle blast is:

$$2.82 \times 0.95 \times \frac{100}{60} = 4.46 \text{ lb/sec}$$

The hot gas is such a minute fraction of the rotor downwash, no ingestion problem is judged to exist; and the downwash would direct the hot gas away from the engine inlet in addition to diluting it.

Experimental determinations of the blast fields resulting from firing the 105mm howitzer indicate that peak overpressures of approximately 0.5 psi can be anticipated at the engine inlet located 28 feet from the muzzle. Engine manufacturers have evaluated the effect of such incident overpressures and have determined that they will have no significant effect on engine operation. The opinion of the engine manufacturer is that the pressure sensor of the fuel control will not even note the occurrence of the transient overpressure due to the high velocity of the blast wave. Neither will the overpressure precipitate compressor stall since stall is triggered by

pressure distortion at the engine inlet rather than uniform overpressure. Engine problems encountered to date which were associated with weapons fired from aircraft have been the general result of very rapid changes in inlet temperature, a factor which is not of concern according to the above discussion.

The impulse generator rocket motor would have exhaust gases at approximately 4,000°F moving at a velocity of 8,000 ft/sec. In the low velocity field of the downwash from the helicopter rotor, the boundaries of this exhaust plume would remain clearly defined. In the plane of the engine inlet, 13 feet aft of the howitzer breech, plume diameter would be four feet; and the plume would completely bypass the engine inlet -- downwash would only serve to deflect the rocket motor exhaust downward, away from the inlet.

GROUND FIRING

The mission scenarios established for aerial artillery include firing the 105mm howitzer on the ground; however, in this application, the impulse generator would not be employed so only the effects of muzzle blast were considered. The howitzer can be fired broadside to the aircraft on the ground, and this mode of firing results in the muzzle being 22 feet from the engine inlet.

For the ground-firing scenario, helicopter rotor blades would be stopped and the engines running at the ground idle setting. The condition is not amenable to analysis, but some simplifying assumptions were made to calculate approximate results. Assuming that 10 rounds were fired in a one-minute period and that the hot gas from firing was dissipated uniformly throughout the surrounding air, a temperature increase of approximately 30°F was calculated for the engine inlet airflow. This result would indicate that the hot gas ingestion problem is not too severe. However, it must remain for actual firing in varying wind conditions to indicate the actual severity of the problem.

WEIGHT, BALANCE, AND CONTROL

The aerial artillery weapons kit consists of heavy fixed and removable components as well as large fuel and ammunition loads so weights and balance have been considered in detail. Substantiation of component weights is presented in Appendix V with detail weight summaries for the design missions presented in this section. The unusual center-of-gravity positions that can be produced as a result of the aerial artillery installations are shown by analysis to introduce no significant problems of stability and control. The change in the balance of the helicopter as the left (removable) howitzers is lowered to the ground from hover is shown to involve only small changes in control.

DESIGN MISSION LOADINGS

The design missions all start with the same equipment on board at takeoff. Table IV shows the effect of the fuel system changes, the addition of the hardpoints provisions, and the weapons kit less howitzers on the weight and balance. The weight empty of the CH-47C from Spec 114-PJ-7103 was used as the basic aircraft. The crash-resistant fuel system was added along with the modifications. The left and right main cells were removed with the pods to make space for installation of the howitzers and necessary support structure. Twenty-four troop seats were removed, leaving nine for the required number of gunners. A 60-gallon ferry fuel tank was installed in the center of the fuselage just forward of the escape hatch, allowing movement of personnel around the fuel tank and also leaving the rescue hatch accessible for unloading supplies. The howitzer support structure, hydraulic hoist support structure, muzzle blast doubler, and frame beef-up weights were calculated from layouts. Actual weights were used for weapons, ammo, and purchased parts.

Balance calculations were prepared to show the extreme horizontal and lateral CG travels. Tables V and VI show the calculations for the forward and aft loadings, and Figure 36 shows the resulting horizontal CG envelope compared to CG limits. The envelope is well within these horizontal limits. Tables VII and VIII show the lateral loading calculations which are summarized in the Figure 37 plot of lateral CG versus horizontal CG. This plot shows that the lateral CG remains within the lateral limits, providing the ammunition is stowed on the left-hand side first and consumed last if the left-hand howitzer is not on the aircraft. When both howitzers are on the aircraft, the lateral CG is within limit regardless of the sequence of ammunition loading or usage.

TABLE IV. WEIGHT AND BALANCE OF AIRCRAFT LESS WEAPONS, FUEL, AMMUNITION, AND USEFUL LOAD

Item	Weight (lb)	Horizontal		Vertical		Lateral	
		Arm (in.)	Moment (in.-lb)	Arm (in.)	Moment (in.-lb)	Arm (in.)	Moment (in.-lb)
Weight Empty CH-47C (Ref. 114-PJ-7103)	20,743	(345)	7,156,190	(146)	3,030,552	0	2,074
Add Crash Resistant Fuel System	586	327	191,798	80	46,880	0	0
Remove Main Fuel Cells, Pods, Backing Board, etc.	-435	314	-136,590	77	-33,531	0	0
Remove Troop Seats and Belts (24)	-93	300	-27,900	85	-7,871	0	0
Hardpoint Provisions	(256)						
Add Forward and Aft Beam Attaching Forgings	25	276	6,900	80	1,988	0	0
Add Frame Reinforcements	60	240	14,400	118	7,080	0	0
Add Muzzle Blast Doubblers	110	107	11,770	100	11,000	0	0
Add Rotor Brake	51	112	5,712	155	7,905	0	0
Add Brackets, etc.	10	362	3,620	148	1,478	-115	-1,152
Weapon Kit Items - Less Weapons	(3,739)						
Add Forward Hoist, Support Beams and Controls	96	164	15,744	122	11,712	64	6,134
Add Gun Platform	155	320	49,600	57	8,835	-115	-17,856
Add Fwd Lateral Gun Support	586	221	129,228	51	29,886	37	21,506
Add Aft Lateral Gun Support	1,328	314	416,992	51	67,728	45	59,096
Add Longitudinal Beam	48	320	15,360	51	2,448	0	0
Add Tie-Down Dogs & Clamps	25	320	8,000	60	1,500	-115	-2,880
Add Elec.Mtr. & Controls (2)	60	320	19,200	50	3,000	51	3,060
Add Gun Fire Control	50	97	4,850	111	5,560	24	1,200
Add Ammo Loader	200	371	74,200	100	20,000	70	14,000
Add Ammo Loader	200	371	74,200	100	20,000	-70	-14,000
Add Ammo Racks	140	372	52,080	90	12,600	38	5,320
Add Ammo Racks	140	372	52,080	90	12,600	-38	-5,320
Add Ferry Fuel Tank	600	290	174,000	87	52,200	0	0
Add Miscellaneous	15	362	5,430	148	2,217	-115	-1,728
Total Weight Empty	24,796	(337)	8,347,680	(134)	3,327,479	(3)	75,588

TABLE V. WEIGHT AND BALANCE FOR FORWARD LOADINGS OF FUEL, AMMUNITION, ETC.

ITEM	WEIGHT	HORIZONTAL		VERTICAL		LATERAL	
	LBS.	ARM	MOMENT	ARM	MOMENT	ARM	MOMENT
Weight Empty	24796.0	(336.7)	8347680	(134.2)	3327479	(3.0)	75588
Pilot & Co-Pilot	400.0	74.5	29800	98.0	39200	0	0
Flight Engineer	200.0	104.9	20980	108.0	21600	0	0
Trapped Fuel	20.0	385.0	7700	100.0	2000	0	0
Unusable Fuel	16.0	314.8	5037	59.0	944	0	0
Unusable Oil	25.0	480.7	12081	164.5	4113	0	0
Usable Oil	28.0	480.7	13460	164.5	4606	0	0
Gunners (3)	600.0	431.0	258600	93.5	56100	-38.0	- 22800
Gunners (3)	600.0	431.0	258600	93.5	56100	38.0	22800
Gunners (2)	400.0	241.0	96400	93.5	37400	-38.0	- 15200
Gunner (1)	200.0	251.0	50200	93.5	18700	38.0	7600
Howitzer	3751.0	265.0	994015	84.0	315084	102.0	382602
Howitzer(Less Tra- versing Beam & Wheels)	3200.0	271.0	867200	84.0	268800	-102.0	-326400
Fuel(10% Ferry 3900 lbs)	390.0	290.0	113100	100.0	39000	0	0
Minimum Flying Weight	34626.0	(319.8)	11074790	(121.0)	4191126	(3.6)	124190
Loading-Fwd To Aft							
Fuel(Full Ferry 3900-390)	3510.0	290.0	1017900	100.0	351000	0	0
	38136.0	(317.1)	12092690	(119.1)	4542126	(3.3)	124190
Fuel-Aux Tanks	3104.0	314.0	974656	76.1	236214	0	0
	41240.0	(316.9)	13067346	(115.9)	4778340	(3.0)	124190
Ammo 30 Rds	1110.0	371.0	411810	90.0	99900	-38.0	-42180
Ammo 30 Rds	1110.0	371.0	411810	90.0	99900	38.0	42180
	43460.0	(319.6)	13890966	(114.5)	4978140	(2.9)	124190
Ammo 2 Cans	1600.0	471.0	753600	90.0	14400	0	0
Total Gross Weight	45060.0	(325.0)	14644566	(113.7)	5122140	(2.8)	124190

TABLE VI. WEIGHT AND BALANCE FOR AFT LOADINGS

ITEM	WEIGHT LBS.	HORIZONTAL		VERTICAL		LATERAL	
		ARM	MOMENT	ARM	MOMENT	ARM	MOMENT
Minimum Flying Wt.	34626.0	(319.8)	11074790	(121.0)	4191126	(3.6)	124190
Loading-Aft To Fwd							
Ammo 2 Cans	1600.0	471.0	753600	90.0	144000	0	0
	36226.0	(326.5)	11828390	(119.7)	4335126	(3.4)	124190
Ammo 30 Rds	1110.0	371.0	411810	90.0	99900	-38.0	-42180
Ammo 30 Rds	1110.0	371.0	411810	90.0	99900	38.0	42180
	38446.0	(329.1)	12652010	(118.0)	4534926	(3.2)	124190
Fuel-Aux Tanks	3104.0	314.0	974656	76.1	236214	0	0
	41550.0	(328.0)	13626666	(114.8)	4771140	(3.0)	124190
Fuel (Full Ferry 3900-390)	3510.0	290.0	1017900	100.0	351000	0	0
Total Gross Weight	45060.0	(325.0)	14644566	(113.7)	5122140	(2.8)	124190

1. WEIGHT EMPTY INCLUDING PROV FOR GUNS, WINCH, FERRY FUEL TANKS, AMMO LOADER & AMMO RACKS
2. MINIMUM FLYING WEIGHT TRAPPED, USABLE & UNUSABLE LIQUIDS, PILOT & CO-PILOT & FLIGHT ENGINEER, NINE GUNNERS, TWO HOWITZERS, 10% FERRY FUEL (390 LBS)
- FWD LOADING
 3. FUEL - FULL FERRY (3900-390)
 4. FUEL - AUX TANKS (3104 LBS)
 5. AMMO-60 RDS (IN RACKS)
 6. AMMO-36 RDS (IN CANS)
- AFT LOADING
 7. AMMO-36 RDS (IN CANS)
 8. AMMO-60 RDS (IN RACKS)
 9. FUEL-AUX TANKS (3104 LBS)
 6. FUEL-FULL FERRY (3900-390)

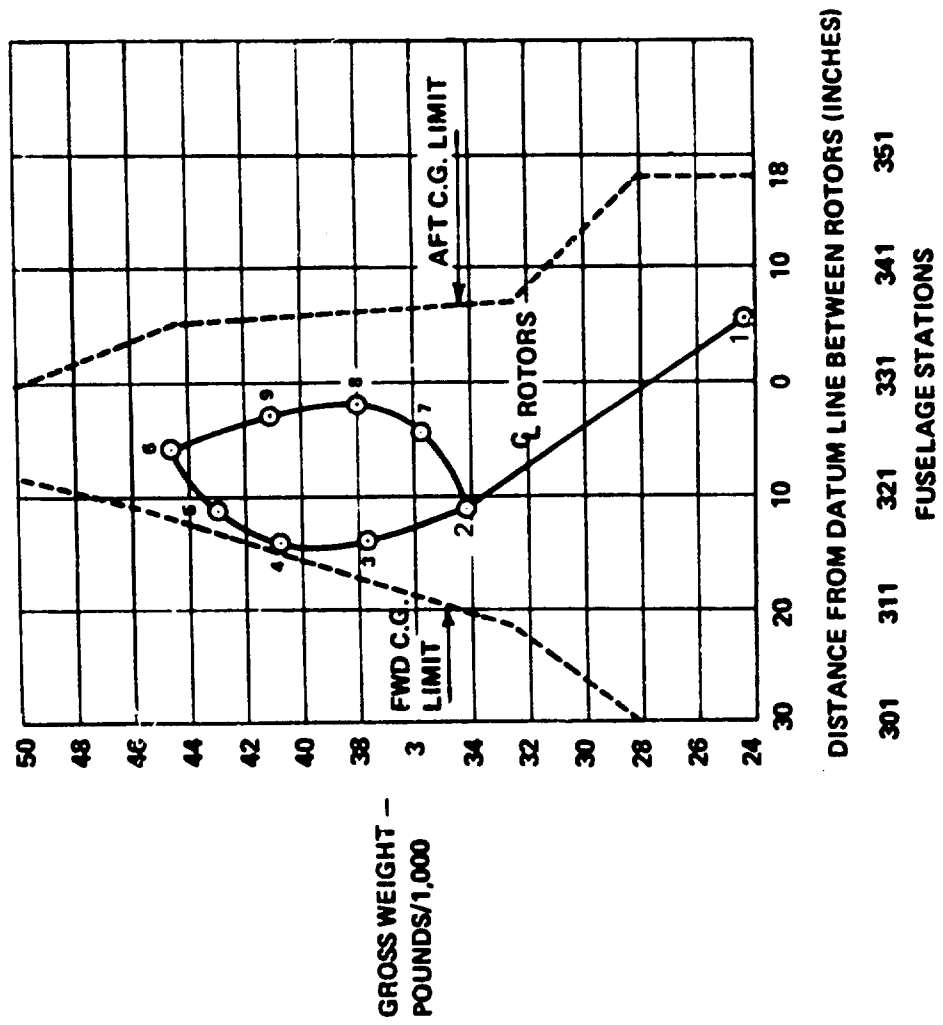

Figure 36. Weight and Longitudinal Balance Are Within Limits for the Design Weapon, Fuel and Ammunition Loading

TABLE VII. BALANCE CALCULATIONS FOR LATERAL LOADINGS

Item	Weight (lb)	Horizontal		Vertical		Lateral	
		Arm (in.)	Moment (in.-lb)	Arm (in.)	Moment (in.-lb)	Arm (in.)	Moment (in.-lb)
Weight Empty	24,796	(337)	8,347,680	(134)	3,327,479	(3)	75,588
Useful Load							
Trapped Fuel	20	385	7,700	100	2,000	0	0
Unusable Fuel	16	315	5,037	59	944	0	0
Unusable Oil	25	481	12,018	165	4,112	0	0
Usable Oil	28	481	13,460	165	4,606	0	0
Pilot and Copilot	400	75	29,800	98	39,200	0	0
Flight Engineer	200	105	20,980	108	21,600	0	0
Total Basic Weight	25,485	(331)	8,436,675	(133)	3,399,941	(3)	75,588
Right-Hand Loading							
Howitzer	3,200	271	867,200	84	268,800	-102	-326,400
Gunnery (5)	28,685	(324)	9,303,785	(128)	3,668,741	(-9)	-250,812
Gunnery (4)	1,000	355	355,000	94	93,500	-38	-38,000
Ammo in Rack	29,685	(325)	9,658,875	(127)	3,762,241	(-10)	-288,812
Ammo in Can	800	386	308,800	94	74,800	38	30,400
Total Right-Hand Loading	30,485	329	9,967,675	(124)	3,837,041	(-9)	-319,212
Total Right-Hand Loading	1,110	371	411,810	90	99,900	38	42,180
Total Right-Hand Loading	800	471	376,800	90	72,000	38	30,400
Total Right-Hand Loading	32,395	(332)	10,756,285	(124)	4,008,941	(-6)	-185,832

TABLE VII. BALANCE CALCULATIONS FOR LATERAL LOADINGS (CONT'D)							
Item	Weight (lb)	Horizontal		Vertical		Lateral	
		Arm (in.)	Moment (in.-lb)	Arm (in.)	Moment (in.-lb)	Arm (in)	Moment (in.-lb)
Total Basic Weight (includes right-hand howitzer)	28,685	(324)	9,303,785	(128)	3,668,741	(-8)	-250,812
Left-Hand Loading Howitzer	3,751	265	994,015	84	315,084	102	382,602
Gunnery (4), L/H	32,436	(318)	10,297,980	(123)	3,983,825	(4)	131,790
	800	386	308,800	94	74,800	38	30,400
Ammo in Rack	33,236	(319)	10,606,690	(122)	4,058,625	(5)	162,190
	1,110	371	411,810	90	99,900	38	42,180
Ammo in Can	800	471	376,800	90	72,000	38	30,400
Most Lateral	35,146	(324)	11,395,300	(120)	4,230,525	(7)	234,770
Gunnery (5), R/H	1,000	355	355,000	94	93,500	-38	-38,000
	36,146	(325)	11,750,300	(120)	4,324,025	(5)	196,770
Ammo in Rack	1,110	371	411,810	90	99,900	-38	-42,180
	800	471	376,800	90	72,000	-38	-30,400
Fuel - Full Ferry	38,056	(329)	12,538,910	(118)	4,495,925	(3)	124,190
	3,900	290	1,131,000	100	390,000	0	0
- Aux. Tanks	3,104	314	974,656	76	236,214	0	0
Total Loading	45,060	(325)	14,644,566	(114)	5,122,139	(3)	124,190

TABLE VIII. SUMMARY, LATERAL TRIM CHANGES WITH WEAPON OFFLOADING

Configuration	Gross Weight (lb)	CG Offset (in.)	Lateral Trim (Hover)		
			Fuselage List Angle (deg)	Lateral Stick Motion (Available 4.2 in.)	
				Inches Used	Percent Available Used
Aerial Artillery Aircraft With 96 Rounds of Ammunition	34,236 Zero Fuel & Ammo GW	3.6 Left	.90 Left	.46 Right	11.0 Right
	41,240 Max. Fuel Gross Wt.	3.0 Left	.15 Left	.39 Right	9.2 Right
	45,060 Max. GW	2.8 Left	.70 Left	.36 Right	8.6 Right
With Detachable Howitzer Offloaded, 36 Rounds of Ammunition	30,485 Zero Fuel Gross Wt.	-8.5 Right	2.12 Right	1.09 Left	26.0 Left
	37,489 Max. Fuel Gross Wt.	-6.9 Right	1.73 Right	.89 Left	21.6 Left
	39,089 Max. GW	-6.6 Right	1.66 Right	.86 Left	20.7 Left

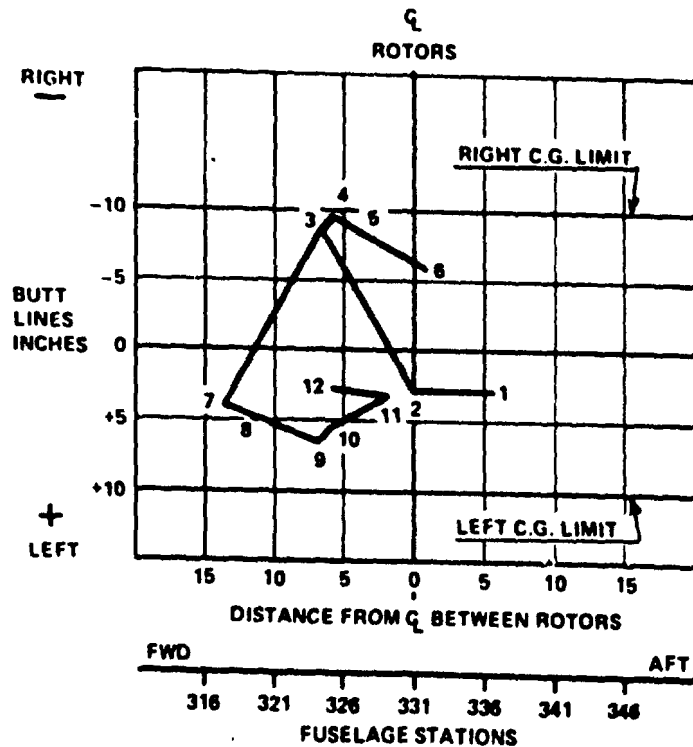

1	WEIGHT EMPTY	24,796 LBS
1 - 2	BASIC WEIGHT - INCLUDES TRAPPED AND USABLE LIQUIDS, PILOT, CO-PILOT, AND FLIGHT ENGINEER	25,486 LBS
2 - 3	HOWITZER - RIGHT SIDE	28,886 LBS
3 - 4	GUNNERS (5) - RIGHT SIDE	29,886 LBS
4 - 5	GUNNERS (4) - LEFT SIDE	30,486 LBS
5 - 6	AMMO - LEFT SIDE (48 RDS)	32,396 LBS
3 - 7	HOWITZER - LEFT SIDE	32,436 LBS
7 - 8	GUNNERS (4) - LEFT SIDE	33,236 LBS
8 - 9	AMMO - LEFT SIDE (48 RDS)	35,146 LBS
9 - 10	GUNNERS (5) - RIGHT SIDE	36,146 LBS
10 - 11	AMMO - RIGHT SIDE (48 RDS)	38,056 LBS
11 - 12	FUEL - FERRY & AUX (7,004 LBS)	45,060 LBS

NOTE: LEFT SIDE AMMO MUST BE STOWED FIRST AND USED LAST WHEN LEFT SIDE HOWITZER IS NOT ON AIRCRAFT.

Figure 37. Lateral-Longitudinal Center of Gravity Diagram CH-47C Aerial Artillery

LATERAL CONTROL, HOVER OFFLOADING OF LEFT WEAPON

When the left weapon is offloaded, an unusually large lateral CG offset results. Lateral trim calculations have been made to ensure that this lateral CG offset does not require excessive amounts of lateral control. The lateral CG extremes are shown in Table VII and Figure 37. The results, summarized in Table VIII, indicate that the static trim attitude and control position changes are within the control and operational limits of the CH-47C. The most critical configuration requires 26.0 percent of available lateral control, thus providing a substantial margin on the 10-percent control remaining limit which is an absolute limit for very restricted flight. Adequate control is available for 35-knot sideward flight. The accompanying fuselage list angle of 2.12 degrees is well within the 3-degree pilot comfort limit.

A summary of the lateral trim attitude limits is shown in Figure 38. The design configuration satisfies all limitations. It is satisfactory that the pilot can fly with sideslip to have level roll attitude at speeds above 130 knots.

- NOTES: 1. HOVER DATA SHOWN IS FOR MINIMUM FLYING WEIGHT OF THIS CONFIGURATION. CRUISE DATA WAS CALCULATED FOR 33,300 POUNDS GROSS WEIGHT.
2. MAXIMUM CRUISE SIDESLIP LIMIT IS 16° AT 150 KNOTS DUE TO SAS AUTHORITY LIMITATIONS.

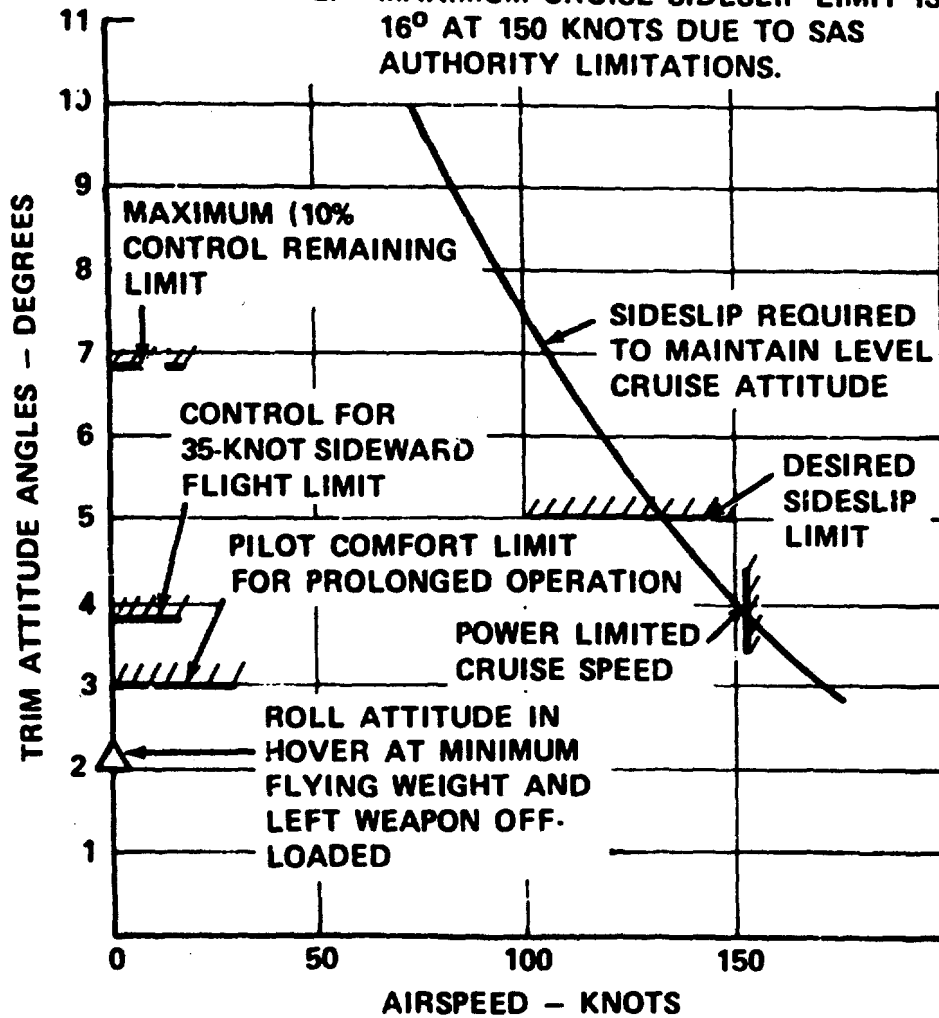

Figure 38. Roll Attitude Limits Versus Airspeed

FLIGHT PERFORMANCE

CONFIGURATION

The primary features of the CH-47C, configured for the artillery role, which affect performance are shown in Table IX. Also noted is the comparable features of a standard CH-47C as described in the Reference 10 detail specification.

TABLE IX. COMPARISON OF AERIAL ARTILLERY CONFIGURATION TO STANDARD CONFIGURATION		
Item	Standard CH-47C	Aerial Artillery Configuration
Rotor System		
Diameter, ft	30	30
Chord, in.	25.25	25.25
Power Plant		
Ratings SL/Std, SHP		
Maximum (10 min)	3,750	3,750
Military (30 min)	3,400	3,400
Normal Power	3,000	3,000
Drive System Rating, SHP	6,000 at 243 rpm	6,000 at 243 rpm
Weights, lb		
Maximum	46,000	46,000
Design	33,000	33,000
Weight Empty	20,743	24,796
Fuel Capacity, gal	1,129	1,078
Hover Download Increase ⁽¹⁾ (DL/T), percent	--	5.25
Equivalent Drag Increase ⁽¹⁾ , ft ²	--	76.2
(1) Relative to CH-47C		

HOVER PERFORMANCE

Figure 39 illustrates the hover capability out-of-ground effect (OGE) of the aerial artillery version of the CH-47C configuration. Also shown on this plot is the hover performance of the CH-47C. Performance is shown at standard temperature and 95°F. As noted, at sea level standard, the aerial artillery aircraft possesses the capability to hover OGE at a gross weight of 43,260 pounds. At 2,000 feet/95°F, this capability lapses to 41,750 pounds or approximately 2,600 pounds less than the standard CH-47C. This reduction in capability is attributable to the increased download of the aerial artillery aircraft which is 5.25 percent (DL/T) higher than the standard CH-47C.

TAKEOFF PERFORMANCE

For the aerial artillery helicopters with mounted weapons and internal cargo, it is not necessary to make a hovering out-of-ground-effect (OGE) takeoff as is required for external payload (sling load) missions. Therefore, in this design, it was assumed that takeoff would be at the maximum alternate weight less warmup fuel (45,060 pounds since two minutes at NRP requires 940 pounds of fuel), with the kind of takeoff depending on the atmospheric conditions. As noted previously, the CH-47C can not hover OGE at sea level standard conditions with the weapons installed due to the increased download. Takeoff would therefore be in ground effect at sea level standard; a running takeoff with lift-off at about 60 knots would be required at 2,000 feet, 95°F. It would be possible to reduce the fuel load by 1,800 or 2,300 pounds to have a hover OGE capability at sea level standard and 2,000 feet, 95°F respectively. These reductions in fuel would reduce the range by about 35 to 40 miles radius.

Figures 40 through 45 illustrate the mission capability of the aerial artillery CH-47C in the following three roles:

- Detachable Howitzer
- Air-to-Ground Firing Mission
- Ground-to-Ground Attached Firing Mission

Mission performance is shown at two ambient conditions: sea level standard day and 2,000 feet/95°F. The ability of the CH-47C in the aerial artillery configuration to accomplish these missions is summarized in Table X.

As shown at a weight commensurate with its ability to hover OGE at sea level standard (43,260 pounds), the aerial artillery version of the CH-47C possesses the ability to transport

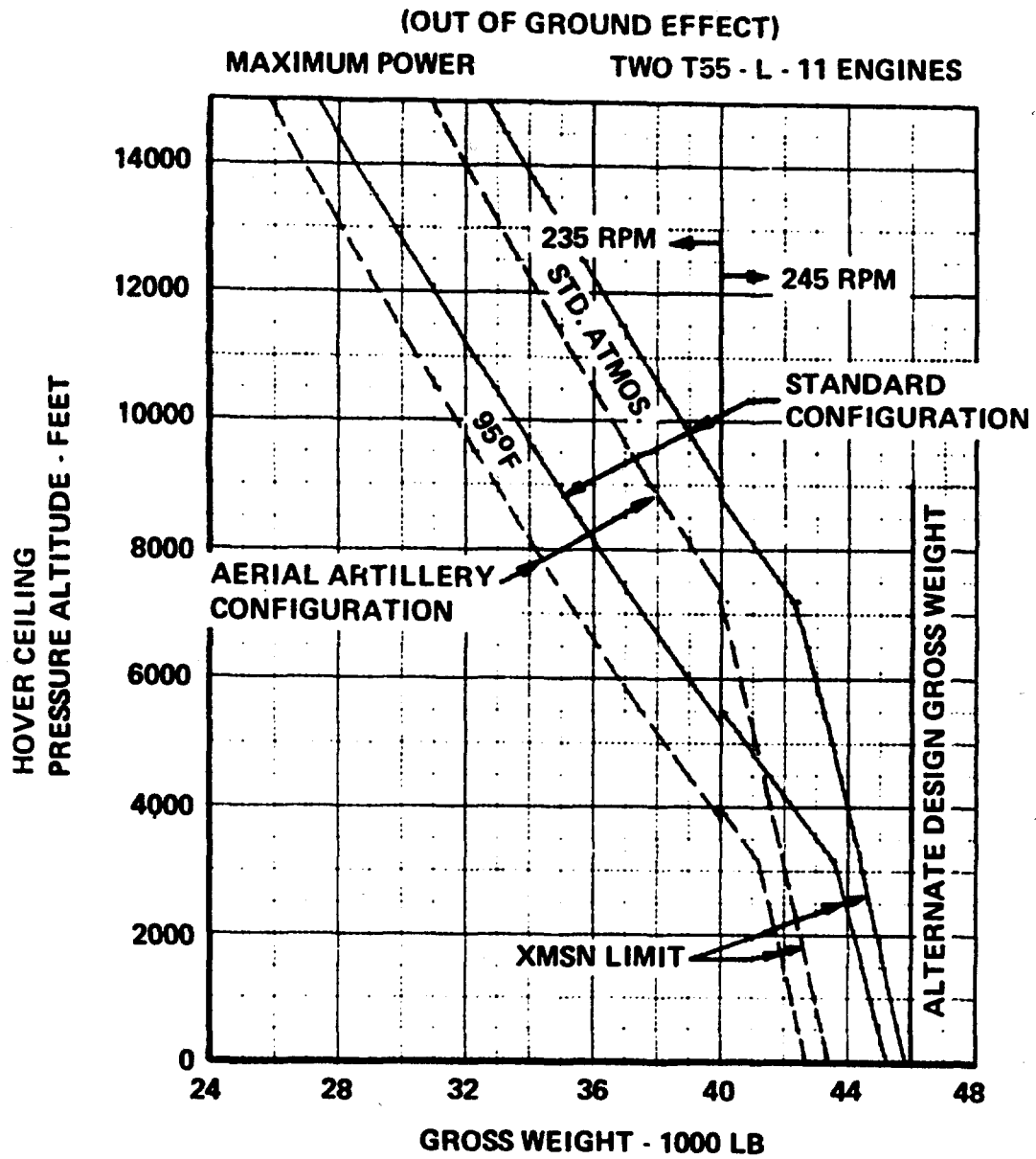
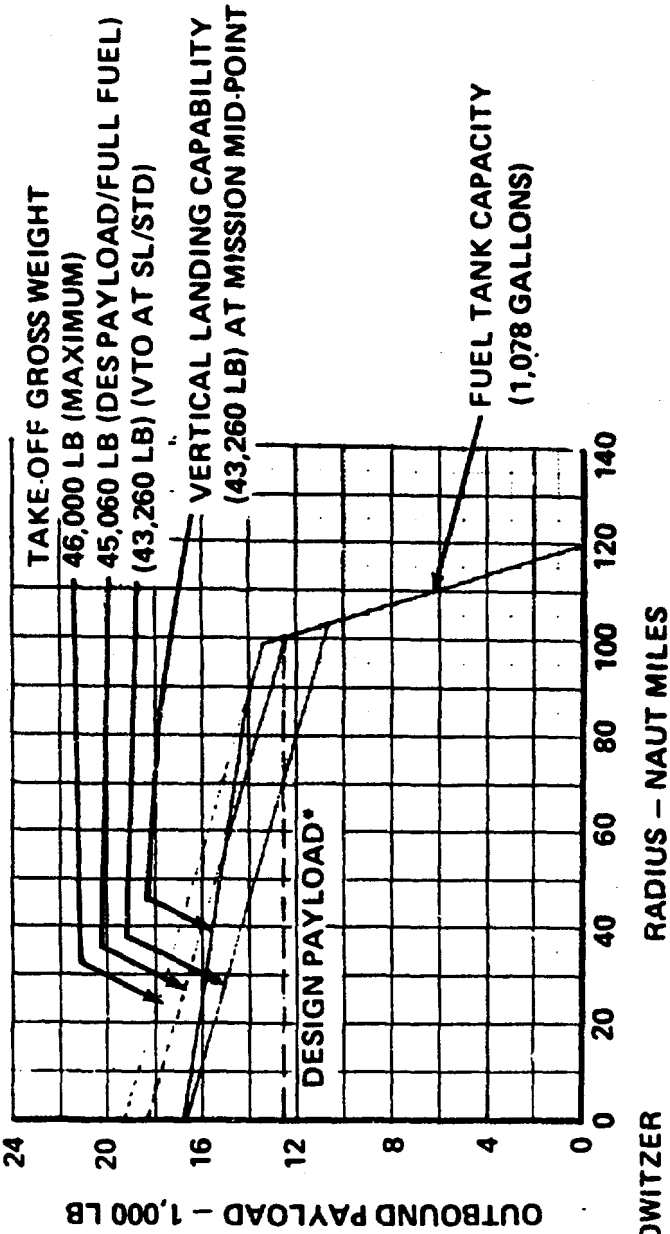

Figure 39. CH-47C Helicopter Hover Ceiling Versus Gross Gross Weight

WARM-UP 2 MIN AT NRP
 CRUISE OUT AT 99% BRS
 HOVER (OGE) 15 MIN AT STATION
 UNLOAD REMOVABLE GUN (3,751 LB), TWO CANS OF AMMO (1,600 LB).
 AND FIVE GUNNERS (1,000 LB) - TOTAL OF 6,351 LB
 CRUISE BACK AT 99% BRS
 LAND WITH 10% FUEL RESERVE
 24,796 LB EMPTY WEIGHT
 689 LB FIXED USEFUL LOAD
 7,004 LB FUEL TANK CAPACITY



- 3,751 LB - REMOVABLE HOWITZER
- 1,600 LB - (2) CANS OF AMMO
- 1,000 LB - (5) GUNNERS
- 3,200 LB - PERMANENT HOWITZER
- 2,220 LB - 60 ROUNDS OF AMMO
- 800 LB - (4) GUNNERS
- 12,571 LB - DESIGN PAYLOAD

Figure 40. Capability of Aerial Artillery CH-47C on Detachable Howitzer Mission at Sea Level Standard Conditions

WARM-UP 2 MIN AT NRP
 CRUISE OUT AT 99% BRS
 HOVER (OGE) 15 MIN AT STATION
 FIRE 60 ROUNDS OF AMMO (2,220 LB) AND SAVE
 AMMO CASINGS (157 LB) - NET 2,063 LB
 CRUISE BACK AT 99% BRS
 LAND WITH 10% FUEL RESERVE
 24,796 LB EMPTY WEIGHT
 689 LB FIXED USEFUL LOAD
 7,004 LB FUEL TANK CAPACITY

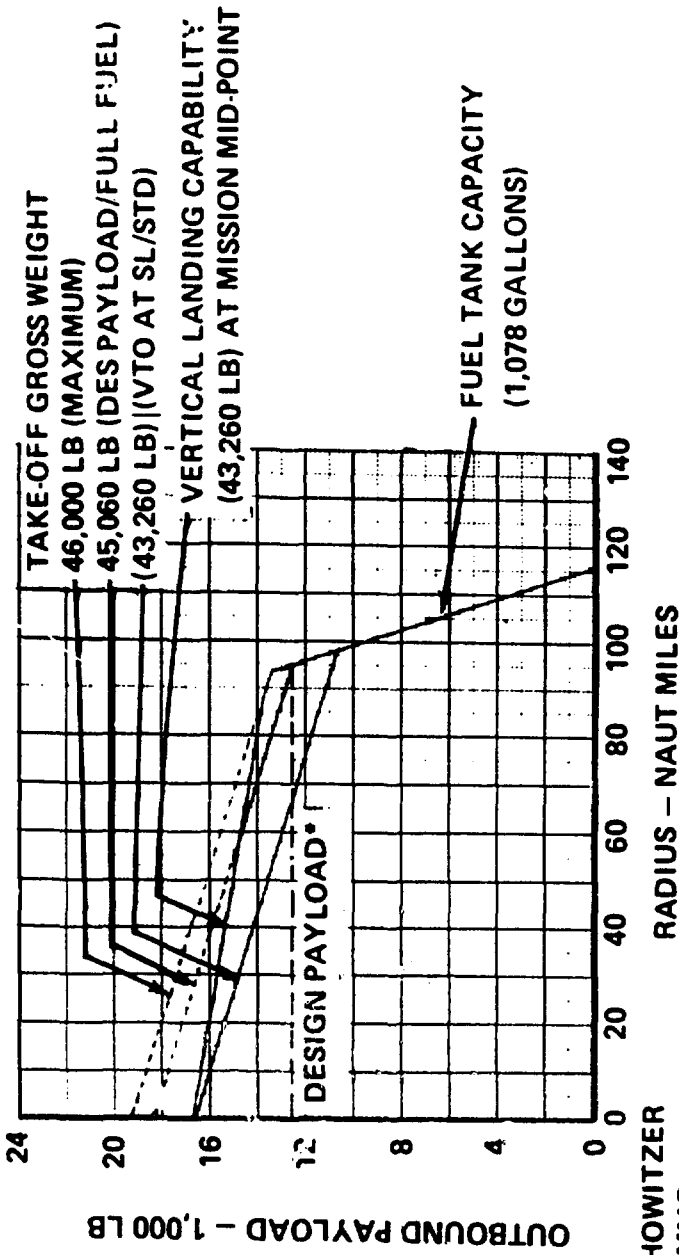

- 3,751 LB - REMOVABLE HOWITZER
- 1,600 LB - (2) CANS OF AMMO
- 1,000 LB - (5) GUNNERS
- 3,200 LB - PERMANENT HOWITZER
- 2,220 LB - 60 ROUNDS OF AMMO
- 800 LB - (4) GUNNERS
- 12,571 LB - DESIGN PAYLOAD

Figure 41. Capability of Aerial Artillery CH-47C on Air-to-Ground Firing Mission at Sea Level Standard Conditions

WARM UP 2 MIN AT NRP
 CRUISE OUT AT 99% BRS
 LAND AT STATION AND STOP ENGINES
 FIRE (2) CANS OF AMMO (36 ROUNDS) FROM PERMANENT
 MOUNTED GUN - 1,600 LB TOTAL
 WARM UP 2 MIN AT NRP
 CRUISE BACK AT 99% BRS
 LAND WITH 10% FUEL RESERVE
 24,796 LB EMPTY WEIGHT
 689 LB FIXED USEFUL LOAD
 7,004 LB FUEL TANK CAPACITY

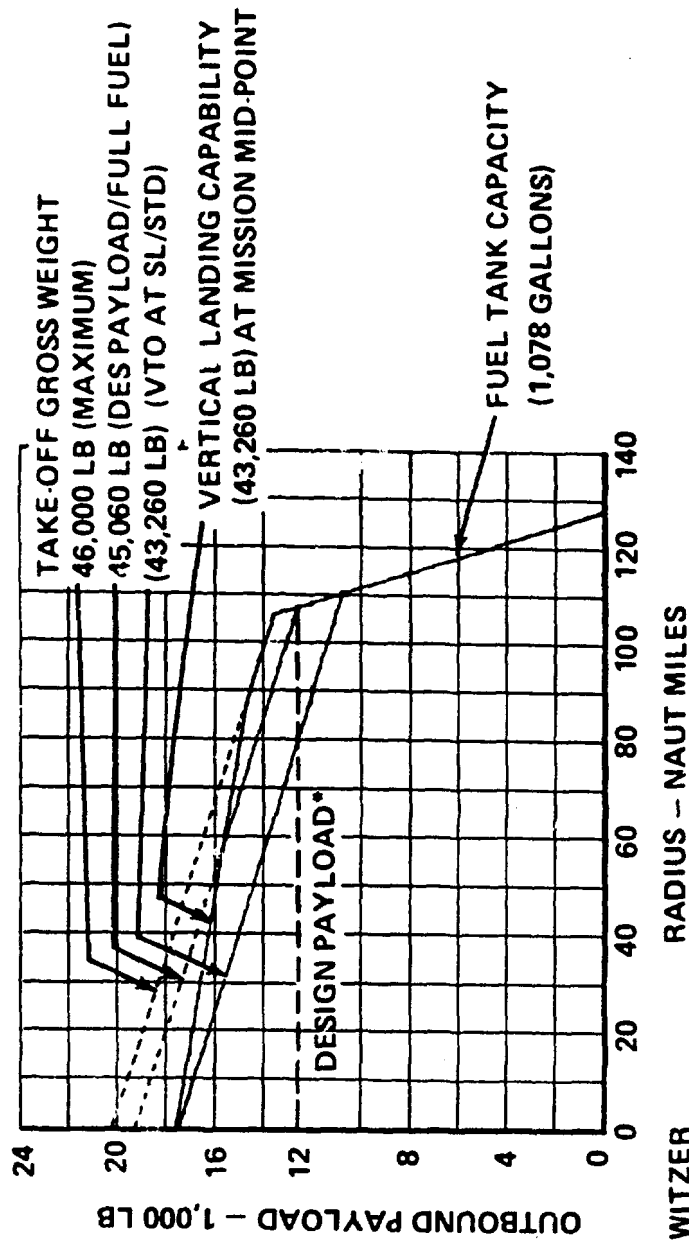

- 3,751 LB - REMOVABLE HOWITZER
- 1,600 LB - (2) CANS OF AMMO
- 1,000 LB - (5) GUNNERS
- 3,200 LB - PERMANENT HOWITZER
- 2,220 LB - 60 ROUNDS OF AMMO
- 800 LB - (4) GUNNERS
- 12,571 LB - DESIGN PAYLOAD

Figure 42. Capability of Aerial Artillery CH-47C on Ground-to-Ground Attached-Firing Mission at Sea Level Standard Conditions

WARM UP 2 MIN AT NRP
 CRUISE OUT AT 99% BRS
 HOVER (OGE) 15 MIN AT STATION
 UNLOAD REMOVABLE GUN (3,751 LB), TWO CANS OF AMMO (1,600 LB),
 AND FIVE GUNNERS (1,000 LB) – TOTAL OF 6,351 LB
 CRUISE BACK AT 99% BRS
 LAND WITH 10% FUEL RESERVE
 24,796 LB EMPTY WEIGHT
 689 LB FIXED USEFUL LOAD
 7,004 LB FUEL TANK CAPACITY

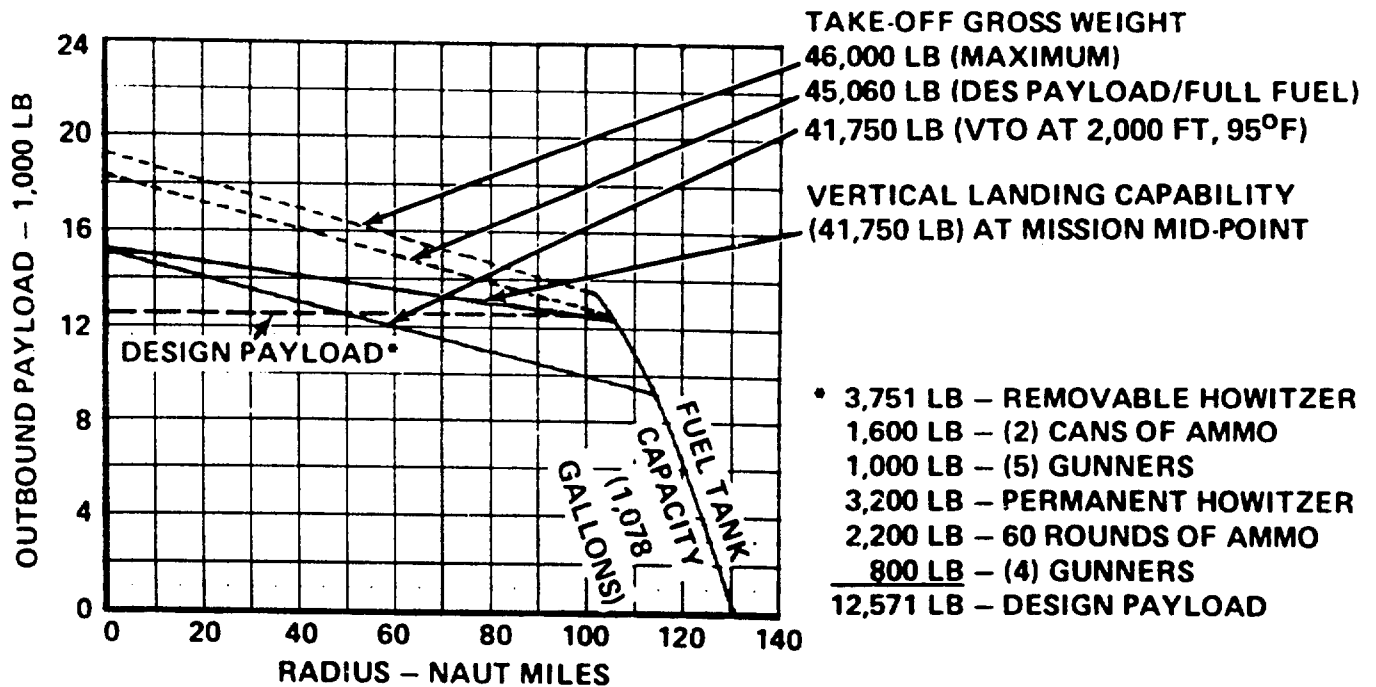

Figure 43. Capability of Aerial Artillery CH-47C on Detachable Howitzer Mission at 2,000 Feet, 95°F

WARM-UP 2 MIN AT NRP
 CRUISE OUT AT 99% BRS
 HOVER (OGE) 15 MIN AT STATION
 FIRE 60 ROUNDS OF AMMO (2,220 LB) AND SAVE AMMO
 CASINGS (157 LB) – NET 2,063 LB
 CRUISE BACK AT 99% BRS
 LAND WITH 10% FUEL RESERVE
 24,796 LB EMPTY WEIGHT
 689 LB FIXED USEFUL LOAD
 7,004 LB FUEL TANK CAPACITY

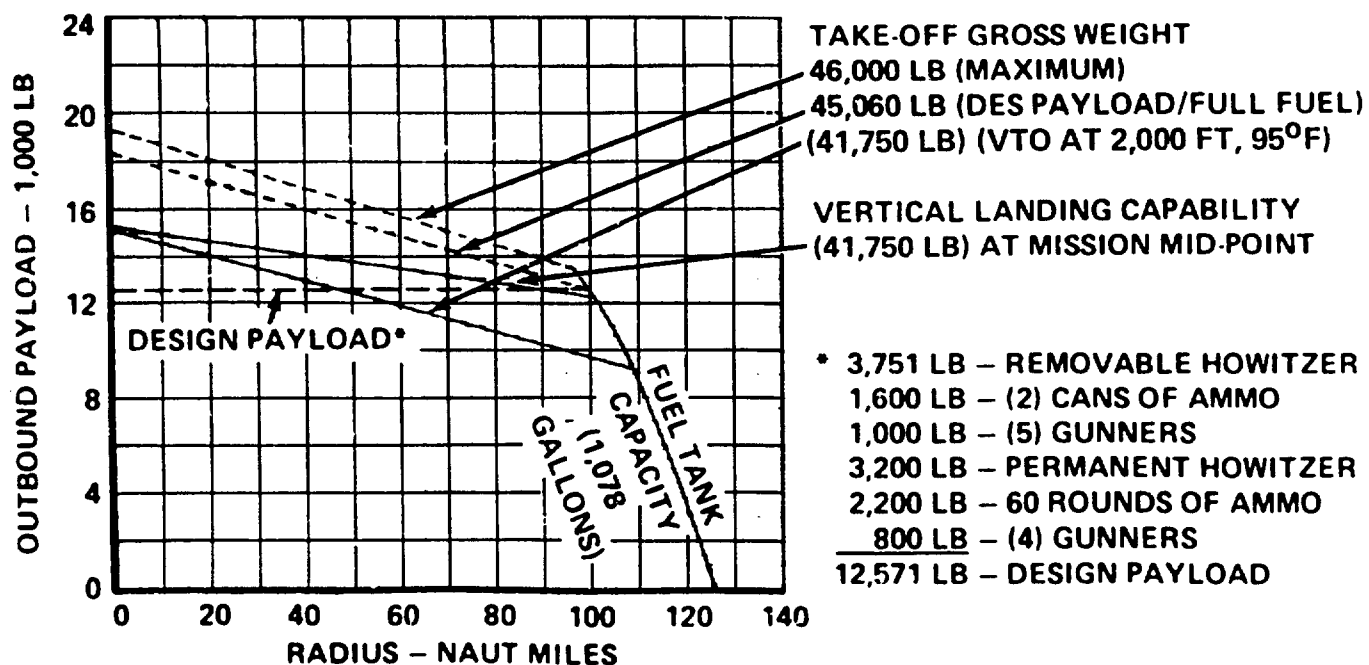

Figure 44. Capability of Aerial Artillery CH-47C on
 Air-to-Ground Firing Mission at 2,000 Feet,
 95°F

WARM UP 2 MIN AT NRP
 CRUISE OUT AT 99% BRS
 LAND AT STATION AND STOP ENGINES
 FIRE (2) CANS OF AMMO (36 ROUNDS)
 FROM PERMANENT MOUNTED GUN - 1,600 LB TOTAL
 WARM UP 2 MIN AT NRP
 CRUISE BACK AT 99% BRS
 LAND WITH 10% FUEL RESERVE
 24,796 LB EMPTY WEIGHT
 689 LB FIXED USEFUL LOAD
 7,004 LB FUEL TANK CAPACITY

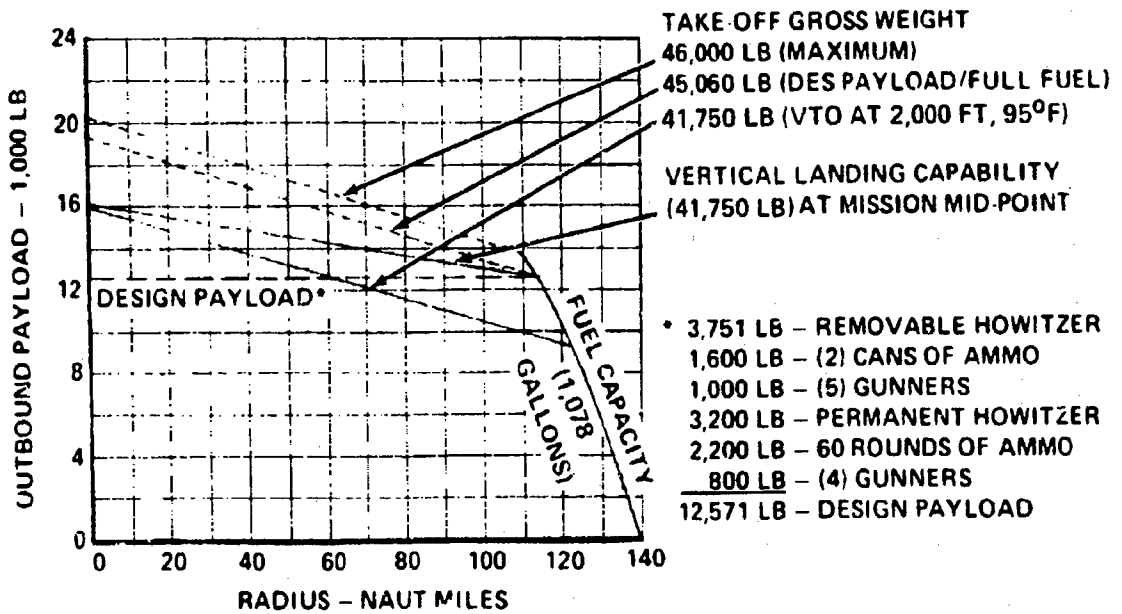

Figure 45. Capability of Aerial Artillery CH-47C on Ground-to-Ground Attached-Firing Mission at 2,000 Feet, 95°F

TABLE X. MISSION PERFORMANCE SUMMARY

Mission	Takeoff Weight	Payload (100 NM Radius)	
		SL/Std	2,000 Ft, 95°F
Detachable Howitzer <ul style="list-style-type: none"> ● Warm up 2 min at NRP ● Cruise out at 99% BRS ● HOGE for 15 min on sta ● Unload 6,351 lb ● Cruise back at 99% BRS ● Land w/10% fuel reserve 	46,000 lb (1) 45,060 lb (2) 43,260 lb (3) 41,750 lb (4)	13,511 lb (5) 12,571 lb 10,850 lb --	13,600 lb 12,750 lb -- 9,950 lb
Air-to-Ground Firing <ul style="list-style-type: none"> ● Warm up 2 min at NRP ● Cruise out at 99% BRS ● HOGE for 15 min on sta ● Fire 60 rds (2,063 lb) ● Cruise back at 99% BRS ● Land w/10% fuel reserve 	46,000 lb (1) 45,060 lb (2) 43,260 lb (3) 41,750 lb (4)	13,511 lb (6) 12,571 lb (7) 10,971 lb (8) --	13,511 lb (9) 12,571 lb -- 9,700 lb
Ground-to-Ground Firing <ul style="list-style-type: none"> ● Warm up 2 min at NRP ● Cruise out at 99% BRS ● Land at sta/stop engines ● Fire 36 rds (1,600 lb) ● Warm up 2 min at NRP ● Cruise back at 99% BRS ● Land w/10% fuel reserve 	46,000 lb (1) 45,060 lb (2) 43,260 lb (3) 41,750 lb (4)	13,900 lb 13,000 lb 11,350 lb --	14,300 lb 13,400 lb -- 10,450 lb
Notes: (1) Maximum Alternate Weight (2) Includes Design Payload (12, 571 lb) (3) HOGE at sea level standard (4) HOGE at 2,000 ft, 95°F (5) 99 Nautical Miles (6) 94 Nautical Miles (7) 95 Nautical Miles (8) 98 Nautical Miles (9) 97 Nautical Miles			

10,850 pounds of payload 100 nautical miles and return to base when performing the detachable howitzer mission. Takeoff for this mission is with the 12,571-pound design payload, and 1,721 pounds of fuel are burned during the 100-nautical-mile flight. During this mission, the aircraft is required to hover 15 minutes on station and return to base with 10 percent fuel reserve. At the mission midpoint, the removable howitzer (3,751 pounds), two cans of ammunition (1,600 pounds), and five gunners (1,000 pounds) are offloaded from the aircraft. At an ambient condition of 2,000 feet, 95°F, for the same mission, the payload capability decreases to 9,950 pounds.

During the air-to-ground firing mission, the aircraft can take off vertically and deliver a payload of 9,750 pounds at 2,000 feet, 95°F over a radius of 100 nautical miles. This mission is based on firing 2,063 pounds of ammo at the midpoint.

The ground-to-ground firing mission calls for the CH-47C aerial artillery aircraft to fire two cans of ammo (36 rounds) from the permanent-mount howitzer after landing at the mission midpoint. At 2,000 feet, 95°F, the CH-47C can perform this mission over a radius of 100 nautical miles, based upon a hover OGE takeoff criteria, with a payload of 10,450 pounds.

PERFORMANCE BASIS

Hover Power Required/Fuel Consumption

CH-47C hover power required is based upon testing of the CH-47C conducted by Vertol and the U. S. Army and documented in Reference 11, Flight Test Report. This data was adjusted for increased download to obtain the hover performance of the aerial artillery aircraft. The hover download contributed by the permanent howitzer and the removable howitzer is indicated in the following table.

HOVER DOWNLOAD (PERCENT TOTAL THRUST)	
Permanent Howitzer	2.90
Removable Howitzer	2.35
Total Increase	5.25

The larger percent download of the permanent-mounted howitzer results due to the drag of the howitzer support platform which is considered a part of the download of this howitzer.

Substantiation of the hover download estimate for the aerial artillery configuration, based on model test data, is presented in Appendix VIII.

Hover power required (OGE) and fuel flow over a range of weights for the CH-47C and its aerial artillery derivative are presented in Figures 46 and 47. Data is presented at an ambient condition of sea level standard and 2,000 feet, 95°F, respectively.

Level Flight Power Required/Specific Range

Level flight performance for the CH-47C is presented upon test data acquired by Vertol and the U. S. Army and documented in the Reference 11 CH-47C Test Report. This data was modified to reflect the increased drag of the aerial artillery configuration. In cruise, the equivalent drag area of the aerial artillery configuration is approximately 2.5 times that of the standard CH-47C configuration. The removable howitzer contributes about two-thirds of the total increase in drag area due primarily to the dual (forward and aft) main howitzer support and dual-winch support beams. The removable howitzer is a complete unit, incorporating undercarriage wheels and traversing beam, which further increases the drag. The total drag increase due to the howitzer installation is shown below.

EQUIVALENT DRAG AREA (fe) (ft ²)	
Permanent Howitzer	24.3
Removable Howitzer	51.9
Total Increase	76.2

Substantiation of the estimated equivalent drag area for the aerial artillery configuration is presented in Appendix VIII.

Level flight power required curves for both the standard CH-47C and the aerial artillery version are presented in Figures 48 through 51. Indicated on the curves are limitations to speed due to available power, transmission torque limits, and the structural flight envelope. Specific range (nautical miles per pound of fuel burned) as a function of airspeed is presented in Figures 52 and 53. Specific range and associated cruise speeds over a range of gross weights for optimum range and maximum continuous cruise speed flight conditions are presented in Figures 54 and 55. Data is shown at sea level

standard and 2,000 feet, 95°F for both the standard aircraft and the aerial artillery version.

Installed Power Available/Fuel Flow

The data presented in this document reflects the performance characteristics of the T55-L-11 engine contained in the Reference 12 Lycoming Model Specification. All mission calculations assume a 5-percent increase in engine manufacturers' stated fuel consumptions.

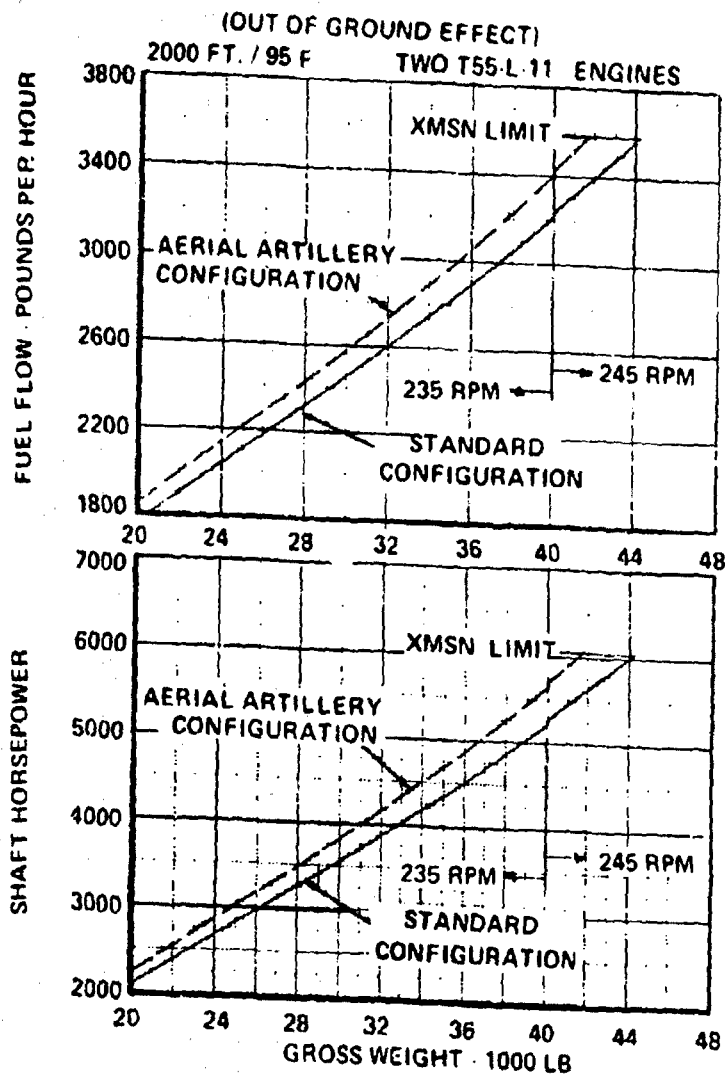

Figure 46. CH-47C Helicopter Hover Power and Fuel Flow Versus Gross Weight

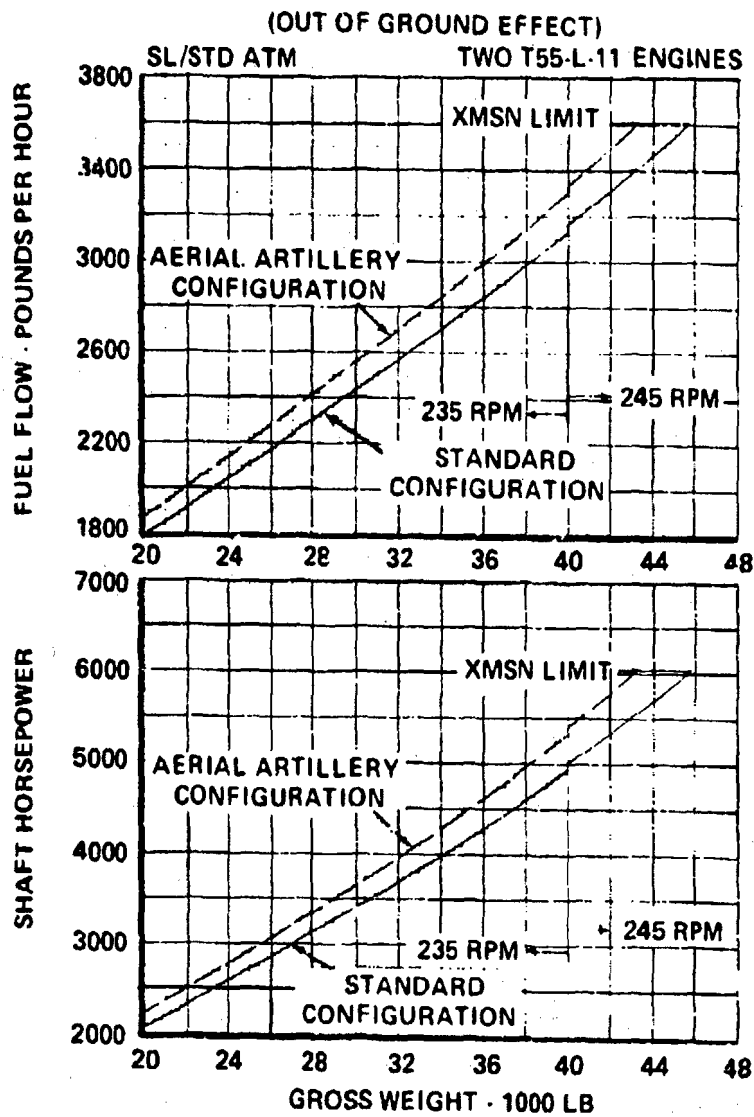

Figure 47. CH-47C Helicopter Hover Power and Fuel Flow Versus Gross Weight

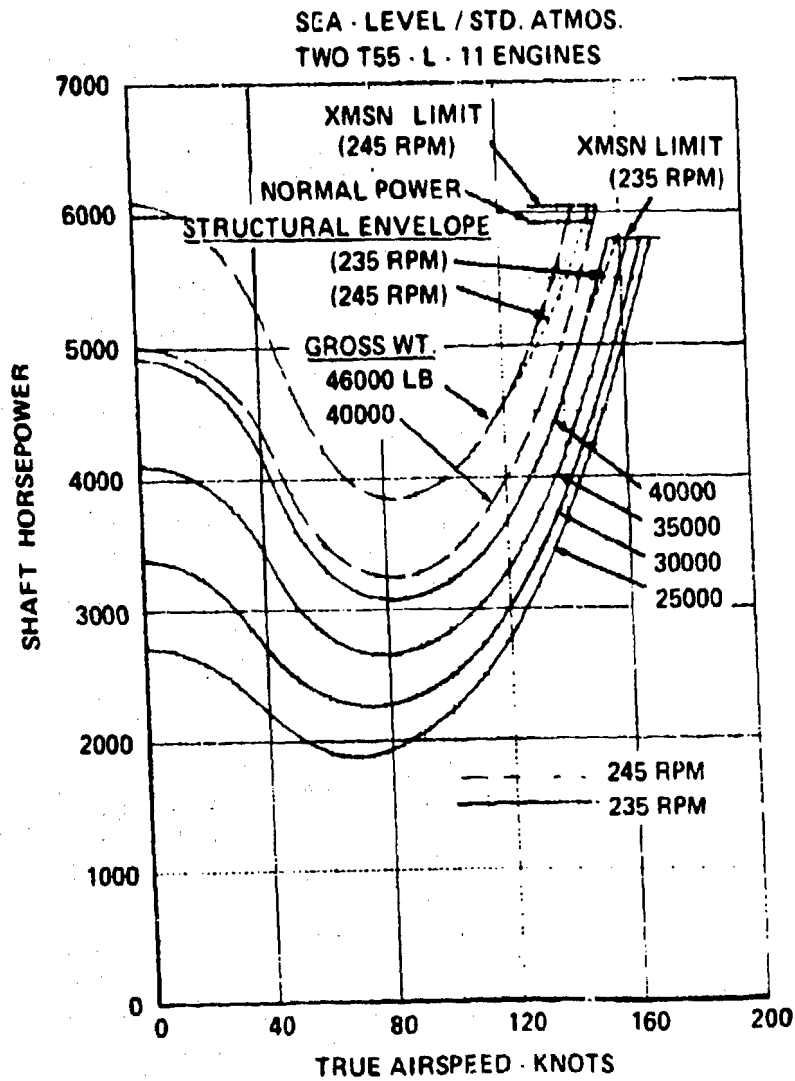

Figure 48. CH-47C Helicopter Standard Configuration Level Flight Power Required

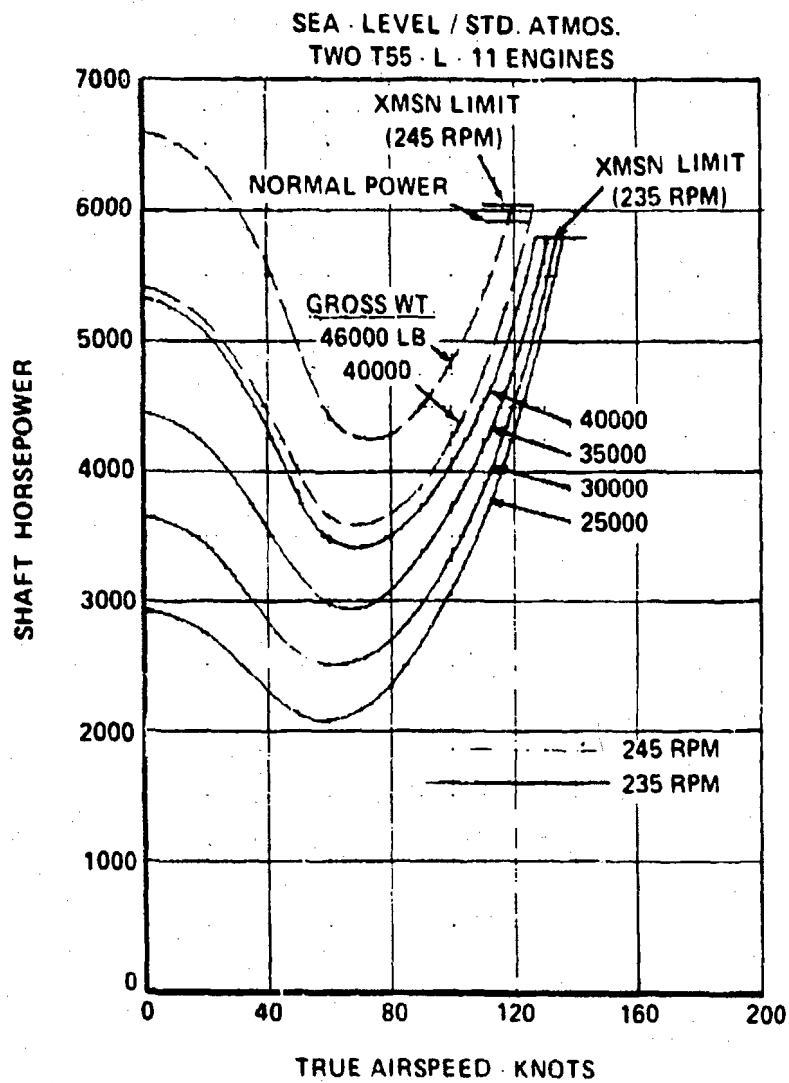

Figure 49. CH-47C Helicopter Aerial Artillery Configuration Level Flight Power Required

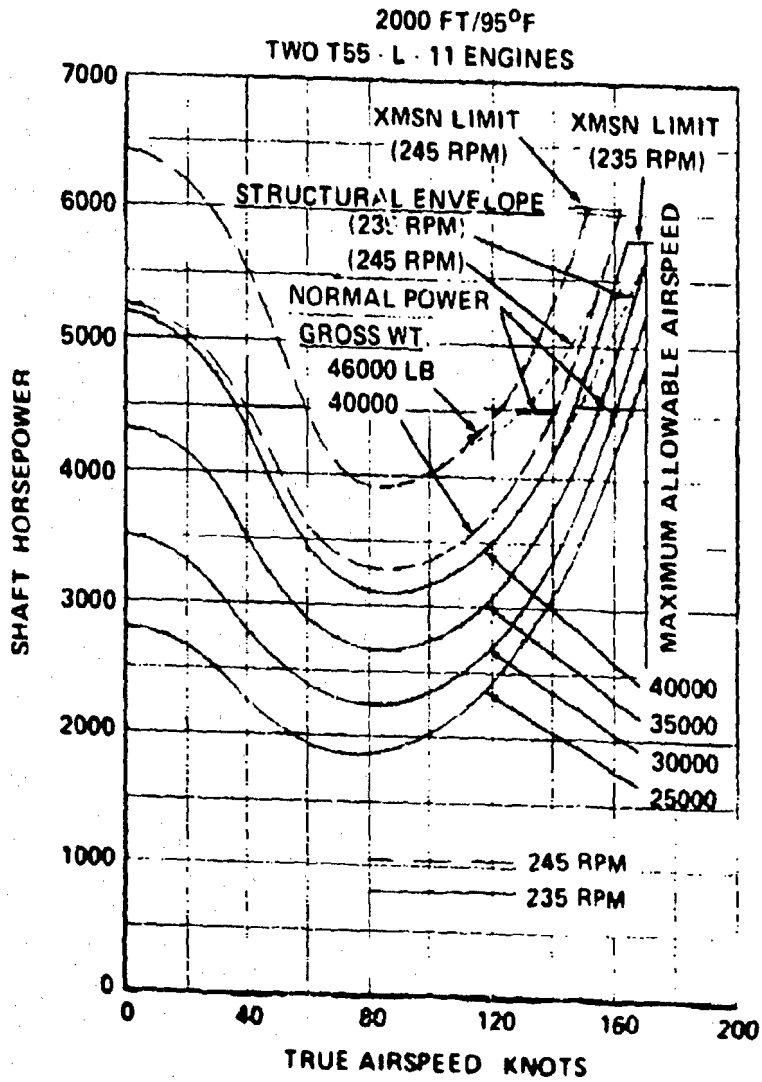

Figure 50. CH-47C Helicopter Standard Configuration Level Flight Power Required

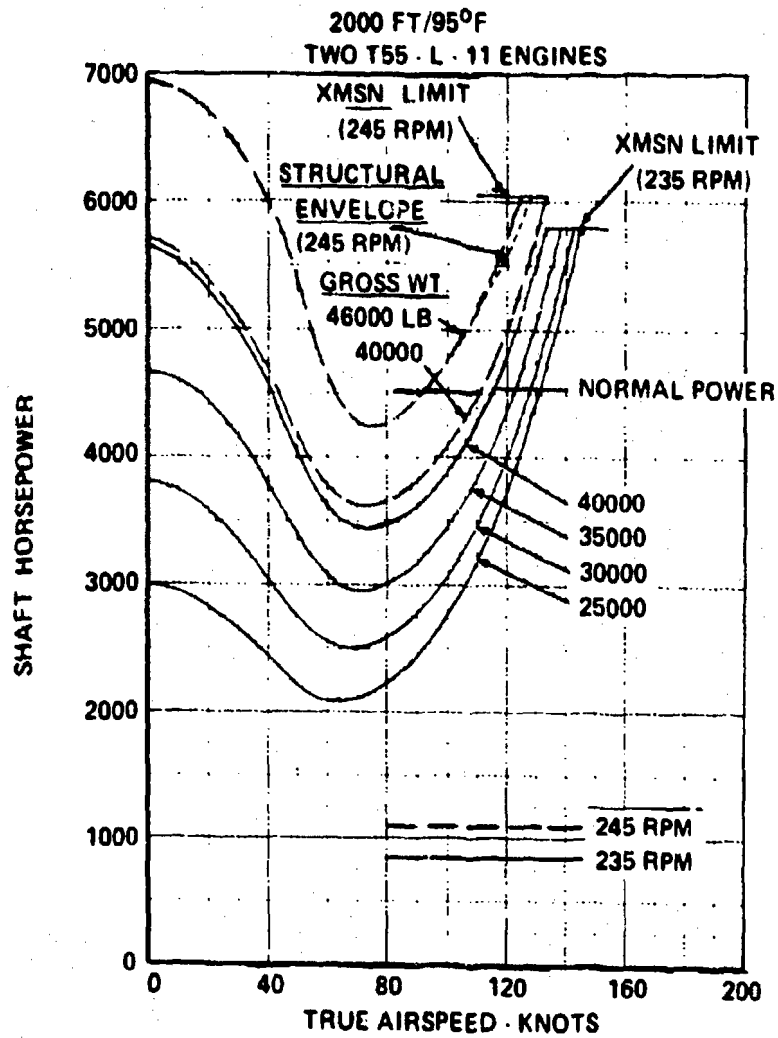

Figure 51. CH-47C Helicopter Aerial Artillery Configuration Level Flight Power Required

SEA LEVEL/STD ATMOS
TWO T55-L11 ENGINES

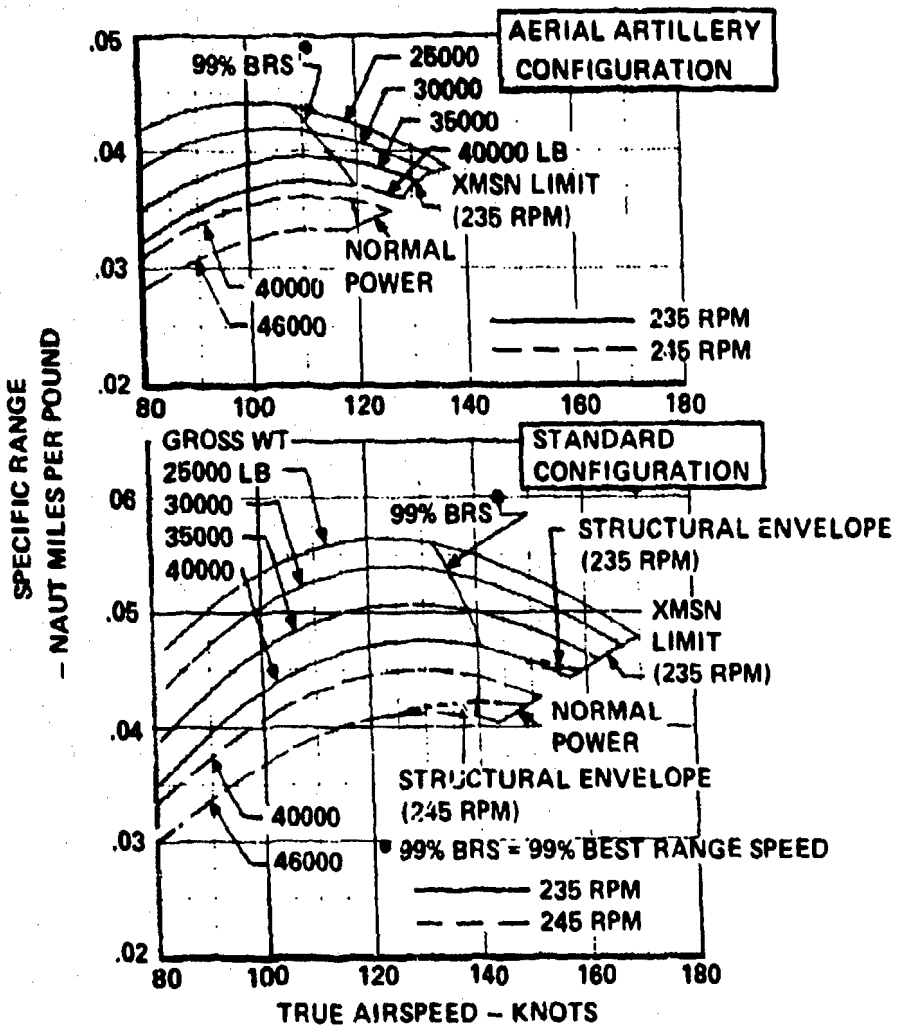

Figure 52. CH-47C Helicopter Specific Range Versus Airspeed

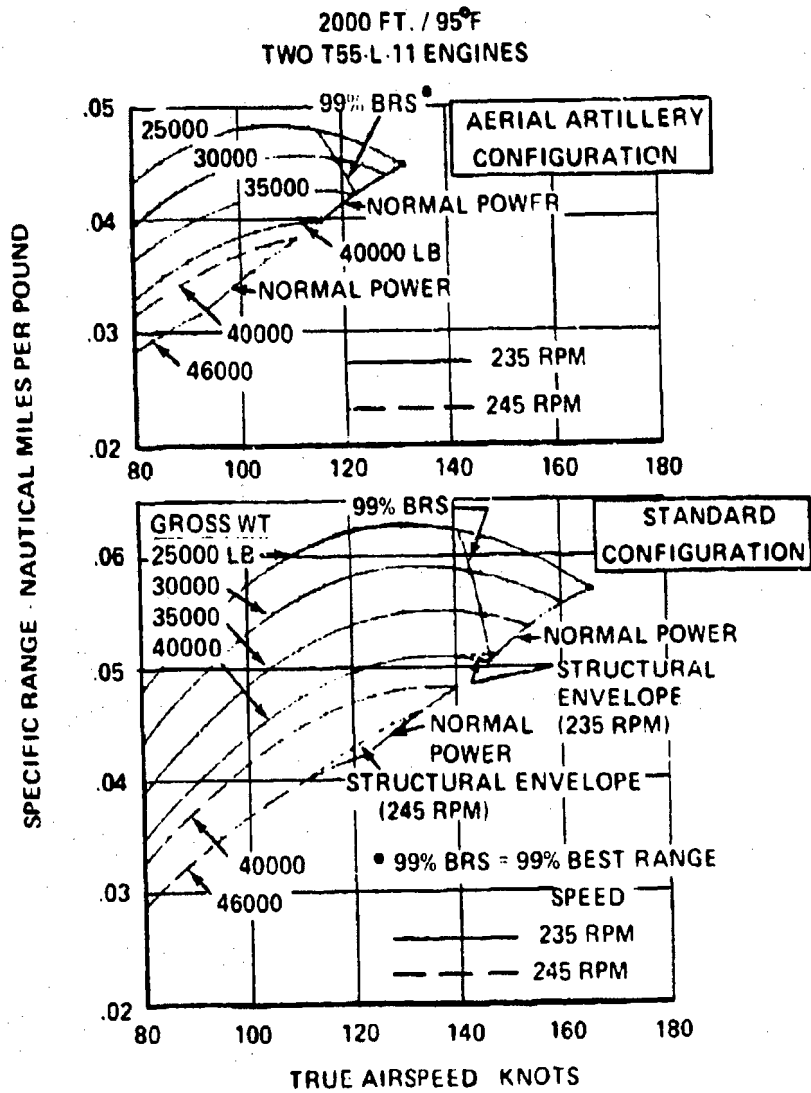

Figure 53. CH-47C Helicopter Specific Range Versus Airspeed

SEA LEVEL/STD ATMOS. TWO T55-L-11 ENGINES
 NOTE: 235 RPM (BELOW 40000 LB) & 245 RPM (ABOVE 40000 LB)

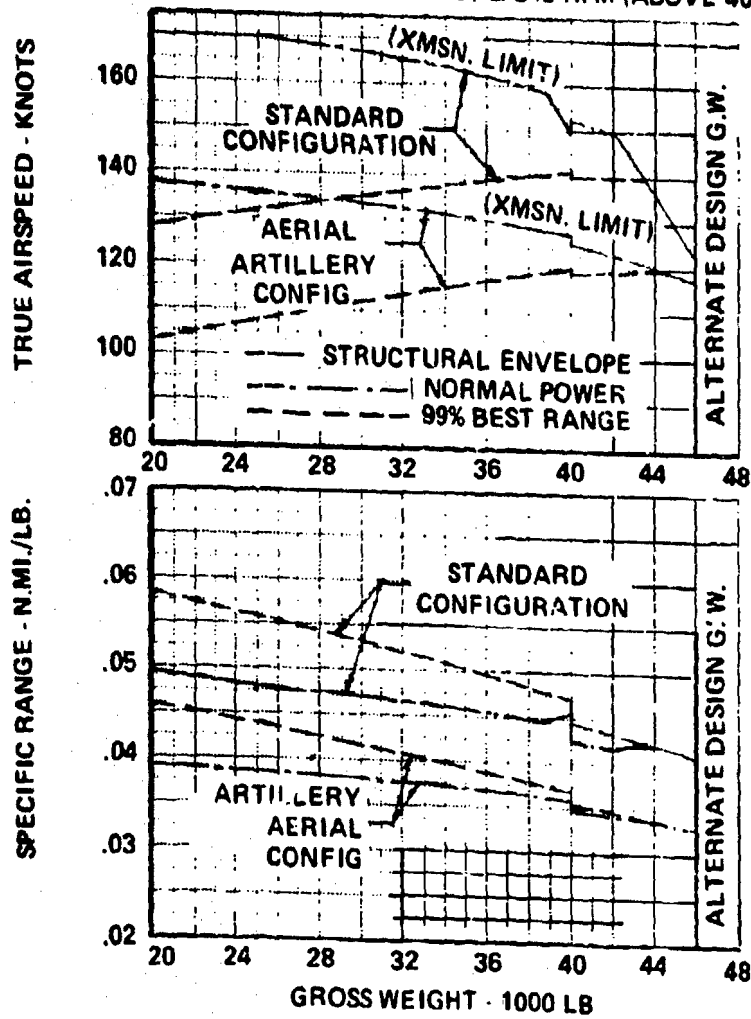

Figure 54. CH-47C Helicopter Specific Range and Cruise Speed Versus Gross Weight

2,000 FT/ 95°F

TWO T55-L-11 ENGINES

NOTE: 235 RPM (BELOW 40,000 LB) AND 245 RPM (ABOVE 40,000 LB)

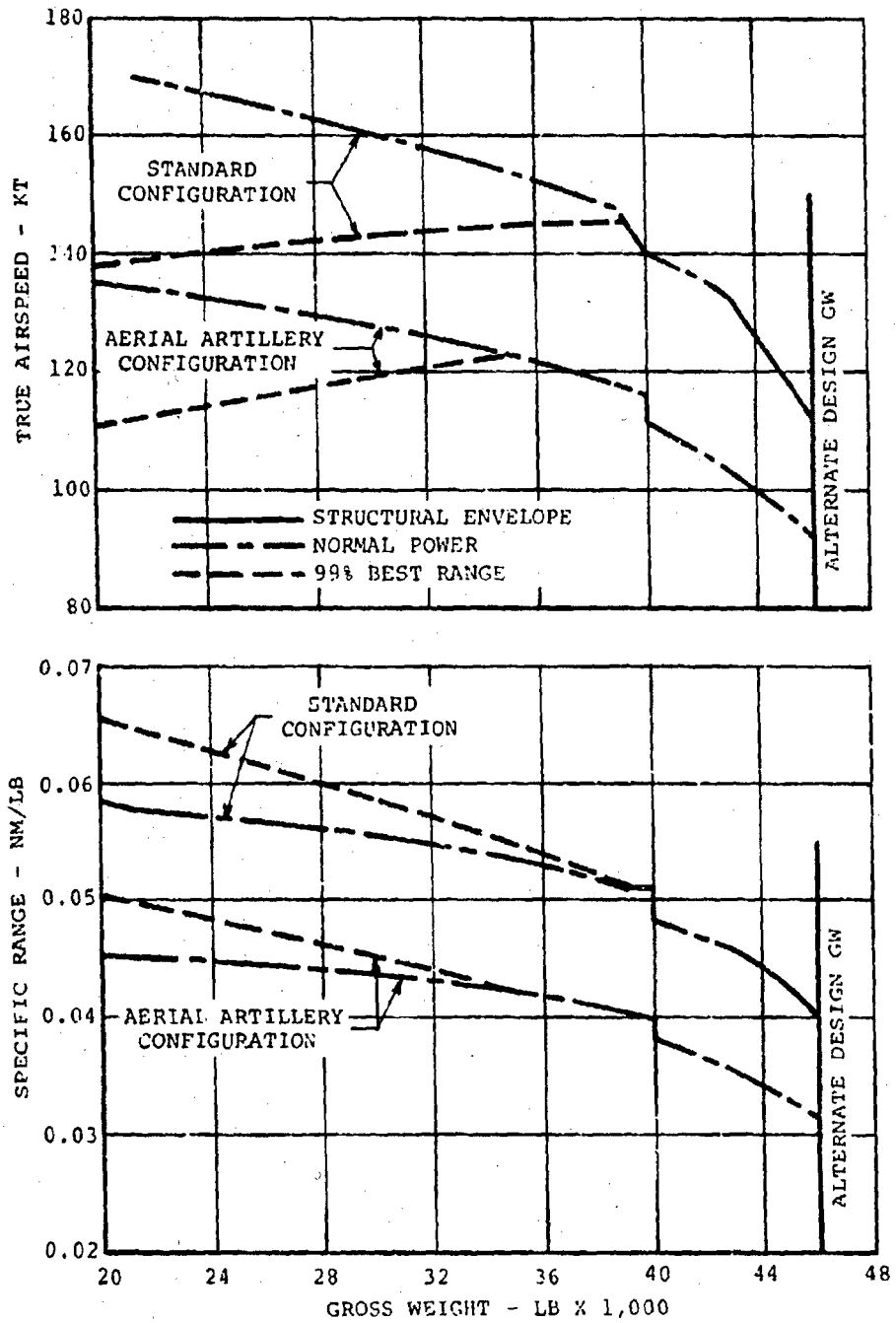

Figure 55. CH-47C Helicopter Specific Range and Cruise Speed Versus Gross Weight

FIRE CONTROL

Conventional artillery fire control equipment is provided in the aerial artillery weapon kit for ground-to-ground firing, and a simple depressible reticle sight is provided for air-to-ground firing. Considerably more sophisticated inertial platform-based target locators, stabilized-magnified sighting systems, etc. could readily be added to increase accuracy, reduce response time, and interface with automated battlefield equipment; but these items have not been considered. In this study, only the most simple, lowest-cost system that could give adequate performance was considered.

GROUND-TO-GROUND FIRING MODE

Firing of the howitzers in either of the two ground-to-ground modes is no different from firing any other artillery piece. Obviously, the detached howitzer introduces no firing complications. The attached howitzer (right side) is mounted on a larger firing base, the helicopter; but again, no new firing problems are introduced. It is necessary that an adequate fire direction center functional capability and authority be part of the aerial artillery firing mission. Provisions are made for a nine-man gun crew to include the men and equipment required for fire direction.

AIR-TO-GROUND FIRING MODE

Air-to-ground firing missions for the aerial artillery helicopter are likely to be either against hostile, well-emplaced enemy positions or to rapidly deny use of areas to the enemy. In either case, the maximum range capability of the 105mm howitzer in direct fire would be utilized to keep the helicopter away from the hot area. A nominal range of 4,000 meters with ability to accommodate ranges of 3,000 to 5,000 meters is provided. The system shown in the design is believed to be able to provide at least 15-mil accuracy and should be adequate to walk the rounds onto the target with the rapid automatic firing capability.

The fire control system provided in the design consists of the following:

- Fixed depressible reticle sight
- Laser rangefinder with mechanical connection to sight
- Artillery binoculars for target detection and identification by crew.

This system represents the least cost approach with the limitations being the ability to acquire targets and aim the weapons.

The sight provided consists of a combining glass mounted in front of the copilot/gunner which has a light and optics for projecting a crosshair on this combining glass. The copilot looks through the combining glass at the target and sees the reticle superimposed over the target. Since the reticle is focused at infinity, it eliminates the eye-focusing problem which normally exists when observing both close and distant objects simultaneously. Also, movement of the pilot's head does not cause a change in the sight line angle to the target. It is assumed that the target has been located and identified by some means other than the fire control sight. This allows the use of the simple sight with no magnification for the solution to the fire control problem. With appropriate contrast and illumination, the unaided human eye can detect objects which subtend one minute of arc. At 4,000 meters,

$R_0 = \text{object size}$

$$(4000) \left[\frac{1}{(5.73)(60)} \right] = 1.163 \text{ meters}$$

Thus, at 4,000 meters, a target can be seen well enough to align the optical sight crosshairs but not well enough to identify the target. The artillery section chief aboard can use his binoculars to locate and identify the targets.

For range determination, a simple, lightweight and relatively inexpensive laser rangefinder is provided. These devices exist as off-the-shelf hardware in production quantities. Since this device has a very narrow beam, it must be changed in elevation every time the sight angle to the target is changed. In order to assure that the elevation boresight between the optical sight and the laser rangefinder is maintained, the laser is coupled mechanically in elevation to the optical sight.

Each time the weapon kit is installed on the hardpoints, the system will have to be boresighted for air-to-ground firing. Since the forward retractable beam can be used to adjust the azimuth of the removable howitzer, both weapons can be adjusted in elevation and azimuth for boresighting. Boresighting therefore requires that a crewman take a target to the nominal range in front of the helicopter; and by use of hand signals, he positions the target at the center of the crosshairs on the sight. Range to the target can be checked with the laser rangefinder which must be adjusted to be aimed at the target. Next, the howitzers would be aimed at the target using the elbow telescope sights and adjusting the elevation with the standard elevation handwheels. Azimuth of the right-side weapon will be adjusted using the azimuth handwheel, and the left-side weapon will be adjusted by positioning the forward retractable beam. A boresight target and a retractable boresight tube are provided so that the left-side howitzer can be reboresighted

inflight after the howitzer is remounted to the helicopter by the hoists. The reboresight target will be a scale which is read during boresighting so that the position of the howitzer can be repeated when the howitzer is remounted. The retractable boresight tube is provided so that the elbow telescope sight on the howitzer can be used from inside the cabin of the helicopter.

Hitting targets in air-to-ground firing requires that the copilot/gunner, the pilot, and the artillery section chief preplan the mission to determine how the target is to be attacked. This is necessary so that the elevation of the two howitzers can be set using the handwheel controls. The problem, illustrated in Figure 56, results from the change in fuselage attitude with airspeed and the large difference in height between the helicopter and the target that can occur. As shown in Figure 57, a correction in gun elevation of about 100 mils must be made if the firing is done at 120 knots rather than at hover. This change in attitude must be added to the elevations from the firing tables (Reference 13) which are a function of delta height and range. It is anticipated that most firing would be accomplished from hover with the helicopter in the nap of the earth so that the delta height is no more than 50 meters. As shown by the Figure 58 data, the howitzers would be set at about 100 mils' elevation for firing in this condition.

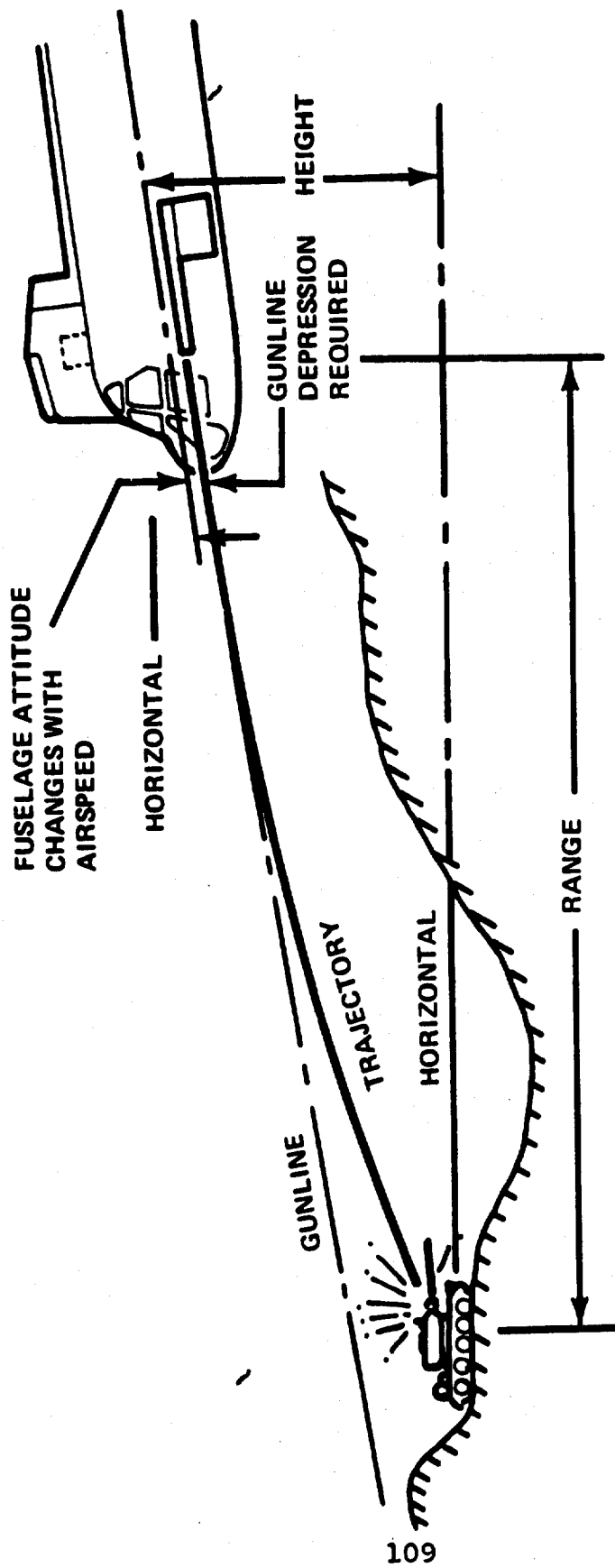

Figure 56. Geometry Involved in the Air-to-Ground Firing

GROSS WT 45,000 LB
AIRCRAFT C.G. STA 325
DENSITY ALT S.L. STD

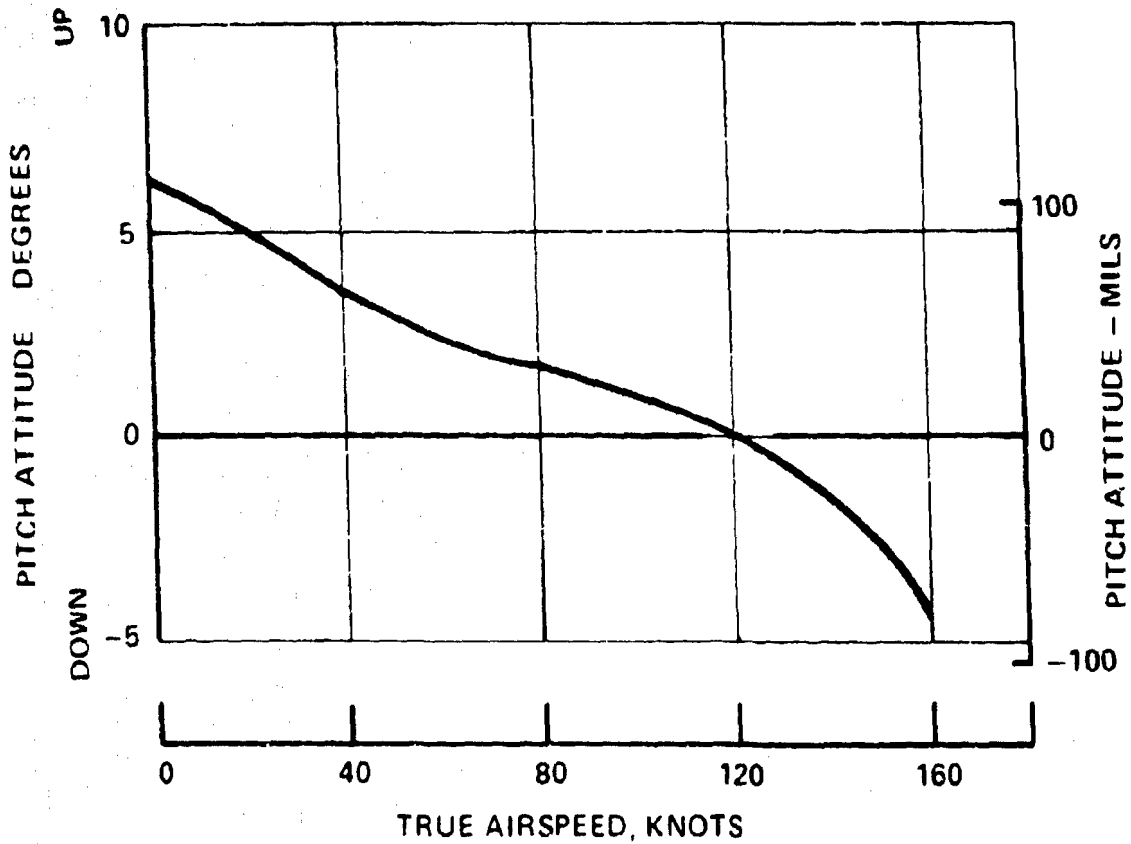

Figure 57. Helicopter Attitude Changes with Flight Speed in Level Flight

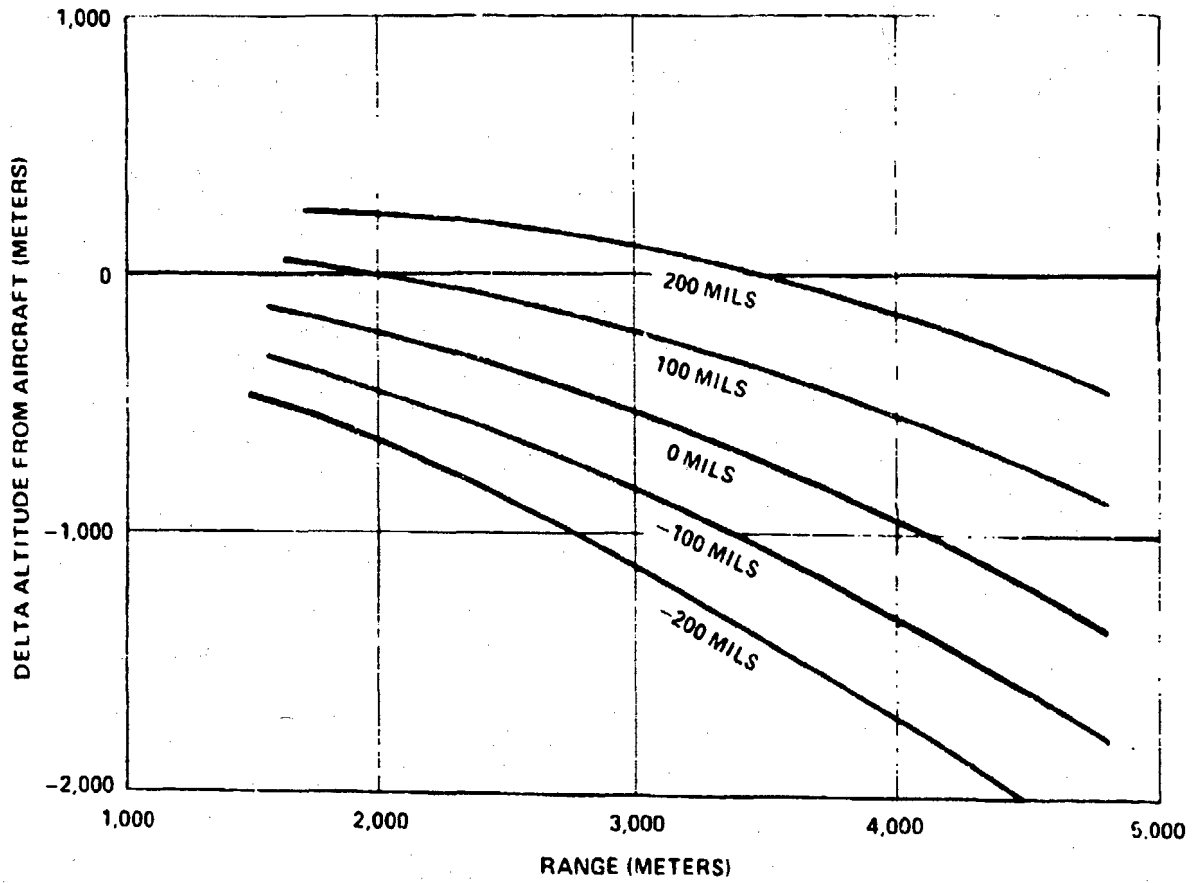

Figure 58. Elevation and Delta Height Relationship for Zone 5, M1 Rounds

CONCLUSIONS

1. Aerial artillery, using the XM204 howitzer and the CH-47C helicopter, is feasible. This concept will provide fire-power and a flexible capability that should warrant further development by the Army.
2. Impulse generators do not appear to be necessary for the CH-47C aerial artillery. Elastic responses of the helicopter to inflight firing without impulse generators show peak accelerations of about 0.17 g. Flight motion simulation of the response of the helicopter to the recoil load which would result from inflight firing without the impulse generator shows that a 3/4-inch, 0.5-second directional control input will negate the response. This control input could be automatic or by the pilot.
3. Dynamic tuning of the mounting structures for the howitzers has an important influence on the vibration of the helicopter and the weapons. Tuning to accept some motion of the howitzers appears to be the approach to give the best compromise between helicopter vibration, howitzer attachment vibratory stresses, and howitzer aiming accuracy.
4. Rotor blade stresses due to inflight firing of zone 5 from the forward-directed weapons are small enough to have a negligible influence on the service life of the rotor system.
5. Due to the continuous operation at high gross weight inherent in the aerial artillery missions, some reduction in the service life of the forward rotor components is required with the present design. This penalty would be alleviated if the CG were shifted back to the aft limit.
6. To provide for the malfunction of an erroneous round selection, muzzle blast doublers for the fuselage and particularly for the transparent areas should be designed not to fail when the largest zone round aboard is fired.
7. Detail design of the aerial artillery installation may show that reinforcement of the fuselage frames under the muzzle blast doubler may be required.
8. Increased aerodynamic hover download and drag due to the weapon installation reduce the hover lift capability about 2,200 pounds and reduce the range about 20 percent compared to a standard CH-47C with internal cargo.
9. It was not required in this study that the normal combat equipment be included. The armor, tool kit, emergency

equipment, and suppressive fire weapons provided in the combat equipment are likely to be needed and should be included in subsequent efforts.

10. A rotor brake is required as part of the weapons kit so that quick response in ground-to-ground attached firing can be provided.

RECOMMENDATIONS

1. The aerial artillery weapon installation and hardpoints kits described in this report should be detail-designed, fabricated and tested. Production of at least enough of these units to acquire operational experience is recommended.
2. Direct air-to-ground firing of the aerial artillery appears to be a sufficiently important firing mode that it should be considered separately. An attractive inflight firing feasibility test could be accomplished using the M102 howitzer and trainable gun mount from the AC-130 (Air Force) program with a sight and fire control avionics available from the MBT-70 program.
3. Helicopter model testing of muzzle blast effects on rotor blade loads could prevent expensive surprises in the development of large-caliber weapon installations on helicopters and should be performed for all such developments.
4. Development of muzzle blast diffusers and/or other muzzle blast alleviation devices for use in helicopters should be continued.

REFERENCES

1. Peck, William B; Nutley, William S.; Yntema, Robert T.; Schwam, Stuart A.; Harley, Robert S., STUDY OF THE "BREATHING" EFFORT ON THE H-21 HELICOPTER, Vertol Division, Boeing Airplane Company, Report R-243, Feltman Research and Engineering Laboratories, Picatinny Arsenal, Dover, New Jersey, March 1961
2. Coppock, Max L. and Schertz, Charles J. STUDY OF THE EFFECTS OF FIRING A 75 MM HOWITZER FROM THE H2IA HELICOPTER, U. S. Army Weapons Command Technical Report 65-1889, Rock Island Arsenal, Rock Island, Illinois, August 1965
3. Coppock, Max L., STUDY OF THE EFFECTS OF FIRING A 105 MM HOWITZER FROM THE H21 HELICOPTER, U. S. Army Weapons Command Technical Report 64-3450, Rock Island Arsenal, Rock Island, Illinois, December 1964
4. Smith, William B., AERIAL ARTILLERY WEAPON (EXTERNALLY MOUNTED CONCEPT) (U), U. S. Army Weapons Command, Rock Island Arsenal, Rock Island, Illinois, November 1970. (Confidential)
5. ENGINEERING DESIGN HANDBOOK, GUN SERIES MUZZLE DEVICES, Franklin Institute, Philadelphia, Pennsylvania/Duke University, Durham, North Carolina; AMCP Pamphlet 706-251, U. S. Army Materiel Command, Washington, D. C., May 1968
6. Salsbury, Mark J., POLAR BLAST FIELD OF 105 MM HOWITZERS, MEASURED AND PREDICTED, Artillery Systems Laboratory Technical Report RE TR 71-11, U. S. Army Weapons Command, Rock Island Arsenal, Rock Island, Illinois, January 1971
7. Kinney, Gilbert Ford, EXPLOSIVE SHOCKS IN AIR, New York, Macmillan, 1962
8. Dobbs, N.; Cohen, E.; Weissman, S., BLAST PRESSURE AND IMPULSE LOADS FOR USE IN THE DESIGN AND ANALYSIS OF EXPLOSIVE STORAGE AND MANUFACTURING FACILITIES, Annals of the New York Academy of Sciences, Vol. 152, Art. 1, October 28, 1968, p. 323.

9. Sewell, Robert G. S. and Kinney, Gilbert Ford, RESPONSE OF STRUCTURES TO BLAST: A NEW CRITERION, NWC TP 4422, Naval Weapons Center, China Lake, California, June 1968
10. DETAIL SPECIFICATION FOR THE MODEL CH-47C HELICOPTER, Boeing-Vertol Report 114-PJ-7103, The Boeing Company, Philadelphia, Pennsylvania, May 1970
11. ANALYSIS OF CH-47C PERFORMANCE FLIGHT TEST, Boeing-Vertol Report 114-FT-712, The Boeing Company, Philadelphia, Pennsylvania, January 20, 1969
12. MODEL SPECIFICATION T55-L-11 SHAFT TURBINE ENGINE LYCOMING MODEL LTC4B-11 Specification 124.27A, Lycoming Division, AVCO Corporation, Bridgeport, Connecticut, May 24, 1968
13. FIRING TABLES, 105 MM HOWITZER, M103, FT 105-AS-2, Headquarters, Department of the Army, November 1967
14. PRELIMINARY DRAFT, TECHNICAL MANUAL, HOWITZER, LIGHT, TOWED; 105 MM SOFT RECOIL, XM204, Artillery Systems Laboratory, Research and Engineering Directorate, U. S. Army Weapons Command, Rock Island Arsenal, Rock Island, Illinois, March 1970
15. STRUCTURAL DESIGN CRITERIA FOR THE CH-47B and CH-47C HELICOPTERS, Boeing-Vertol Report 114-SS-603, The Boeing Company, Philadelphia, Pennsylvania
16. INVESTIGATION OF IMPACT OF RVN FLIGHT SURVEY DATA ON FATIGUE CRITICAL COMPONENTS, Boeing-Vertol Report 114-SS-025, The Boeing Company, Philadelphia, Pennsylvania
17. AERONAUTICAL AND STRUCTURAL DESIGN REQUIREMENTS, Naval Air Systems Command Specification AR-56, Department of the Navy, Washington, D. C.
18. FORWARD LANDING GEAR ANALYSIS FOR THE CH-47C HELICOPTER, Boeing-Vertol Report 114-S-05.1, The Boeing Company, Philadelphia, Pennsylvania
19. CH-47C DYNAMIC SYSTEM FATIGUE ANALYSIS FINAL REPORT, Boeing-Vertol Report 114-SS-723, The Boeing Company, Philadelphia, Pennsylvania

20. STRUCTURAL DESIGN MANUAL, Boeing-Vertol DM 8611, The Boeing Company, Philadelphia, Pennsylvania
21. Roark, Raymond J., FORMULAS FOR STRESS AND STRAIN, New York, McGraw-Hill Book Company, 1965
22. CH-47B and CH-47C METAL ROTARY WING ULTIMATE STRENGTH ANALYSIS (CONFIGURATIONS IA AND II), Boeing-Vertol Report 114-SS-607.2.1, The Boeing Company, Philadelphia, Pennsylvania, March 1967
23. Westine, Peter S., MODELING THE BLAST FIELD AROUND NAVAL GUNS AND CONCEPTUAL DESIGN OF A MODEL GUN BLAST FACILITY, Southwest Research Institute; Final Technical Report 02-2643-01, U. S. Naval Weapons Laboratory, Dahlgren, Virginia, September 1970
24. Westine, Peter S., and Hoese, Fred, BLAST GAUGE FOR MEASURING SHOCKS WITH SHORT WAVE LENGTHS, Southwest Research Institute; Interim Report Contract N00178-69-C-0318, U. S. Naval Weapons Laboratory, Dahlgren, Virginia, May 1970
25. Long, George, 105 MM BLAST TESTS AND ANALYSIS, (U) NWL Report (Unnumbered), U. S. Naval Weapons Laboratory, Dahlgren, Virginia, February 1972, (Confidential)

APPENDIX I

HELICOPTER AND WEAPON PARAMETERS

Reference 10 is the detail specification for the model CH-47C helicopter. The following data, extracted from Reference 10 has been used as the basic helicopter parameters for this study.

SCOPE

Helicopter Designation

This specification covers the requirements for the design and construction of the following transport helicopter:

U. S. Army Designation	CH-47C
The Boeing Company, Vertol Division	Model 114
Number and Places for Crew	Three (3)
Number and Kind of Engines	Two (2) T55-L-11 (Lycoming)

Figure 59 is a three view drawing of the CH-47C showing external measurements.

Mission

The primary tactical mission of the Model CH-47C helicopter is to provide air transportation for cargo, troops and weapons within the combat area. In addition, this helicopter will be suitable for special support function. This aircraft shall be suitable for operations during day, night, visual and instrument conditions. The helicopter shall be designed to perform the following specific missions.

I. Mission I - Design Mission

Hover OGE* (6,000 Ft. 95°F)
100 Nautical Mile Combat Radius
Payload 12,000 pounds outbound
6,000 pounds inbound

*OGE = Out of Ground Effect

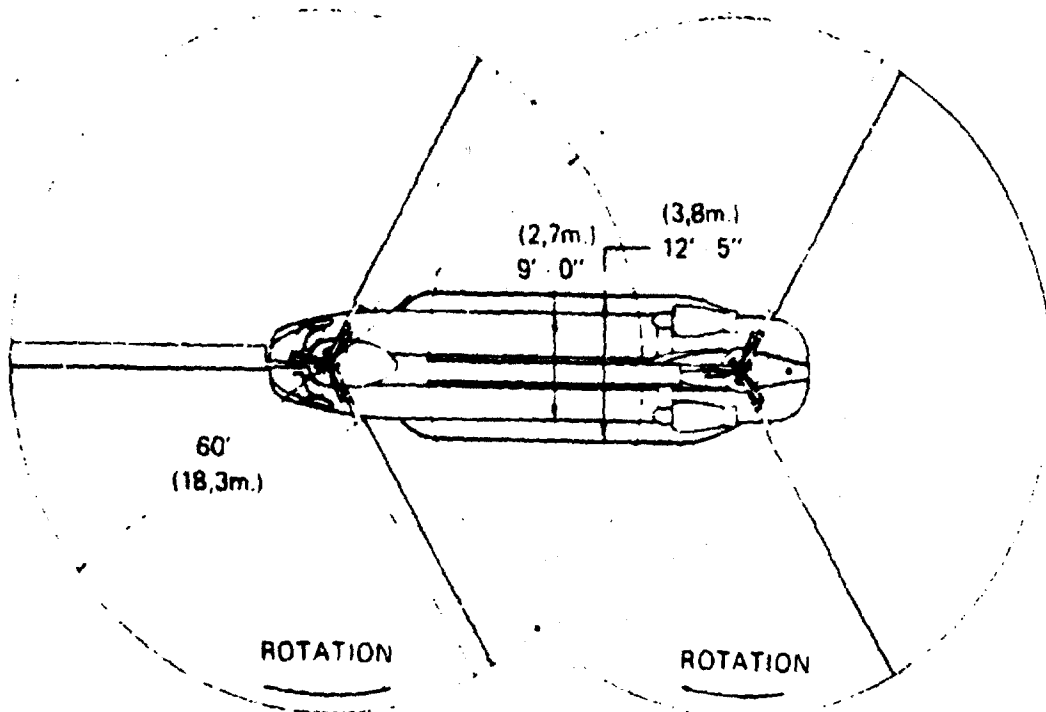

**CH-47C
THREE-VIEW**

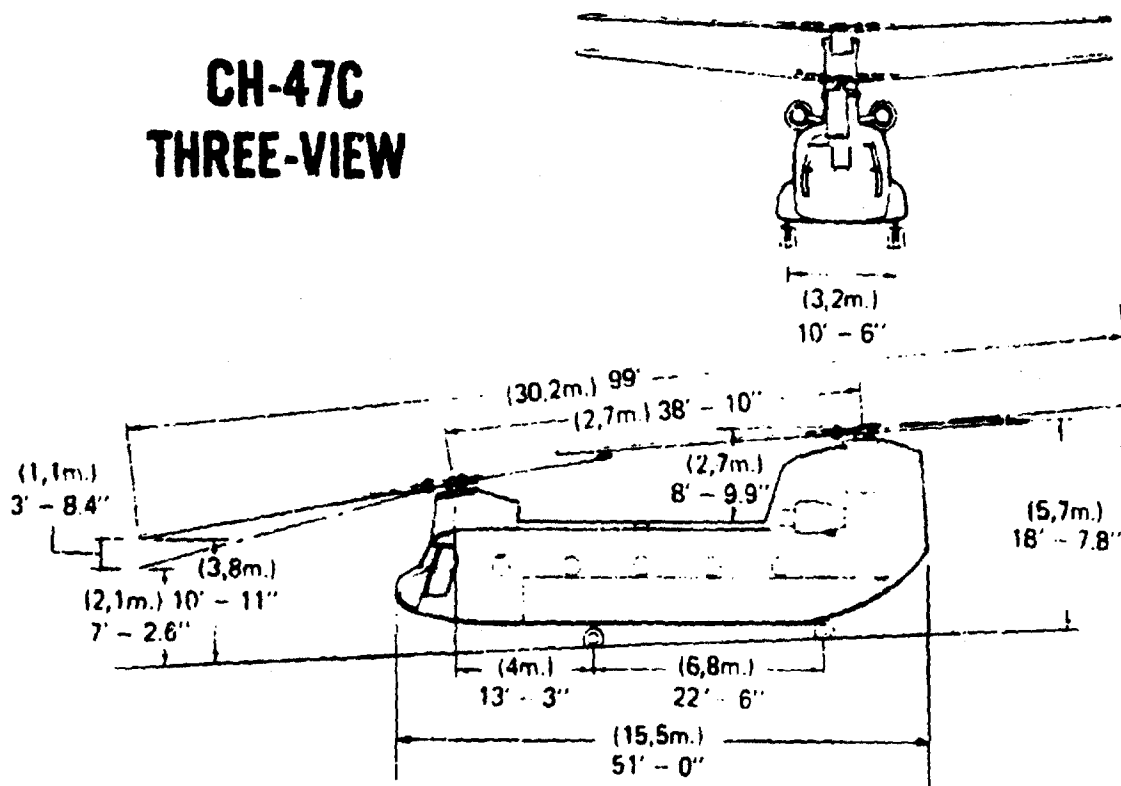

Figure 59.

II. Mission II - Design Gross Weight Mission

Design Gross Wt. 33,000 Pounds
100 Nautical Mile Combat Radius
Payload 7,350 pounds outbound
3,675 pounds inbound
Sea Level/Standard Atmosphere

III. Mission III - Alternate Gross Weight Mission

Alternate Design Gross Weight - 46,000 Pounds
100 Nautical Mile Combat Radius
Sea Level Standard/Atmosphere

IV. Mission IV - External Cargo Mission

Gross Weight - 46,000 Pounds
External Cargo Capability - 20,000 pounds
20 Nautical Mile Radius
Flat Plate Area - 26 sq.ft.

V. Mission V - Ferry Mission

Alternate Design Gross Weight - 46,000 Pounds
Ferry Mission Internal Fuel and
Aux. Tankage

Design, Design Data and Tests

The testing, analysis, and design required in this specification will be satisfied by tests, analysis, and design conducted under Contract AF33(600)39492, AF33(657)9036, AF33(657)-13157, AF33(600)42055, AF33(657)7004, AF33(657)9486, AF33(657)-12258, AF33(657)13529, AF33(657)14888, DA 23-204-AMC-04087(Y), DAAJ01-67-0001(M), DA 23-204-AMC-04366(Y), DAAJ01-68C-0577(M), DAAJ01-68C-1784(M), DAAJ01-68C-1566(M).

Gross Weight

Design Mission Gross Weight (6000 ft., 95°F)	39,200 lb.
Design Gross Weight	33,000 lb.
Alternate Gross Weight	46,000 lb.

II. Mission II - Design Gross Weight Mission

Design Gross Wt. 33,000 Pounds
100 Nautical Mile Combat Radius
Payload 7,350 pounds outbound
3,675 pounds inbound
Sea Level/Standard Atmosphere

III. Mission III - Alternate Gross Weight Mission

Alternate Design Gross Weight - 46,000 Pounds
100 Nautical Mile Combat Radius
Sea Level Standard/Atmosphere

IV. Mission IV - External Cargo Mission

Gross Weight - 46,000 Pounds
External Cargo Capability - 20,000 pounds
20 Nautical Mile Radius
Flat Plate Area - 26 sq.ft.

V. Mission V - Ferry Mission

Alternate Design Gross Weight - 46,000 Pounds
Ferry Mission Internal Fuel and
Aux. Tankage

Design, Design Data and Tests

The testing, analysis, and design required in this specification will be satisfied by tests, analysis, and design conducted under Contract AF33(600)39492, AF33(657)9036, AF33(657)-13157, AF33(600)42055, AF33(657)7004, AF33(657)9486, AF33(657)-12258, AF33(657)13529, AF33(657)14888, DA 23-204-AMC-04087(Y), DAAJ01-67-0001(M), DA 23-204-AMC-04366(Y), DAAJ01-68C-0577(M), DAAJ01-68C-1784(M), DAAJ01-68C-1566(M).

Gross Weight

Design Mission Gross Weight (6000 ft., 95°F)	39,200 lb.
Design Gross Weight	33,000 lb.
Alternate Gross Weight	46,000 lb.

Center of Gravity Locations

Center of gravity locations at design gross weight are as follows: NOTE: See envelope diagram below for flight CG extremes versus gross weight.

Design Gross Weight

C G location forward of datum line between rotors: 3.1 in. fwd. (Condition: Center of Gravity of cargo located at middle of cargo floor).

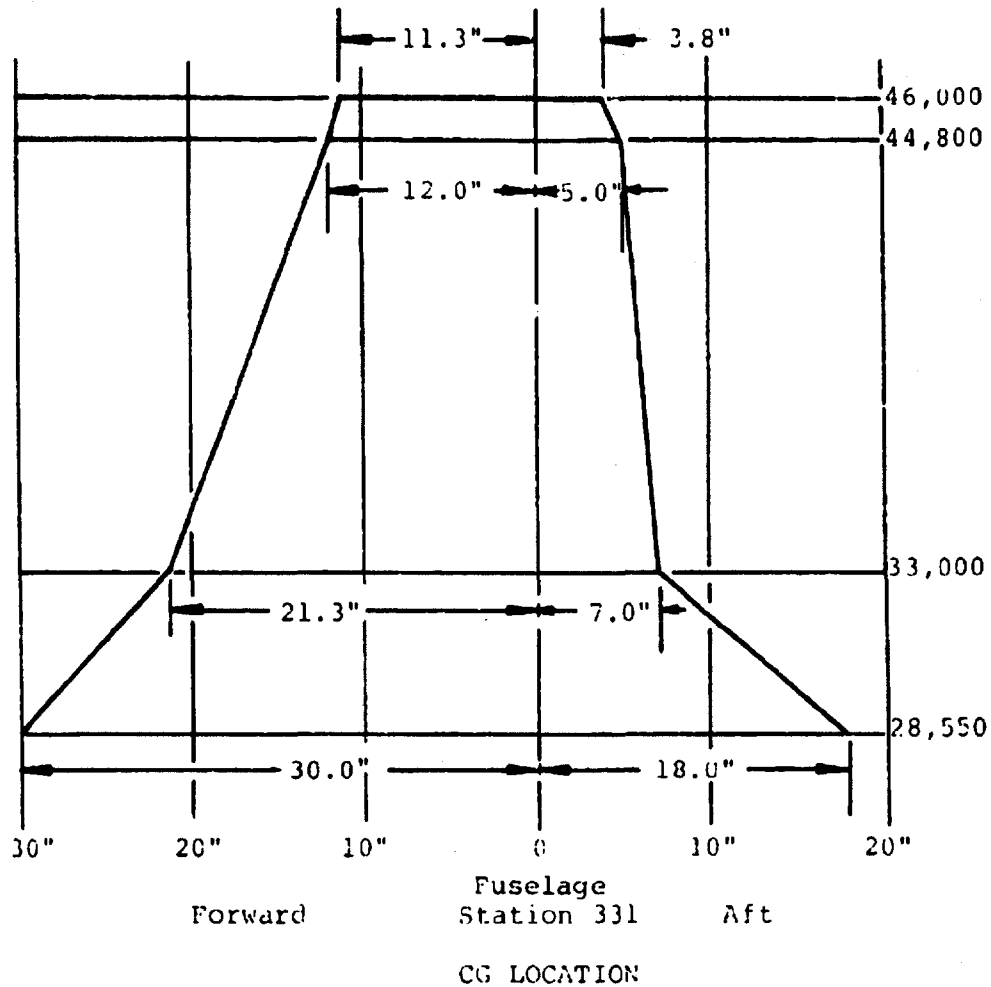

Areas

The principal areas are estimated to be as follows:
(Not to be used for inspection purposes.)

Rotor Blade Area (6 at 63.1 sq.ft.)	379 sq.ft.
Swept Disc Area (per MIL-STD-832) ($\frac{1}{2}$ Rotation To Tip)	approx. 5000 sq.ft.
Geometric Solidity Ratio	.067
Geometric Disc Area	5,655 sq.ft.
(2 rotors at 2,827 sq. ft.)	

Dimensions and General Data

The following information is not to be used for inspection purposes:

Wheel Size

Wheels (Forward Gear)	24 x 7.7 VII
Wheels (Aft)	24 x 7.7 VII

Tire Size

Wheels (Forward Gear) (Ten Ply Rating)	8.50 - 10 III
Wheels (Aft Gear) (Ten Ply Rating)	8.50 - 10 III

Tread of Wheels

Forward Gear	10 ft. 6 in.
Aft Gear	11 ft. 2 in.

Wheel Base	22 ft. 5.9 in.
------------	----------------

Vertical Travel of Axle from Fully Extended to Fully Compressed Position

Forward Gear	11 in.
Aft Gear	11.5 in.

Angle Between Lines Joining Center of Gravity with Points
of Ground Contact of Outboard Forward Wheels

Tires - Static Deflection of 1W
(front elevation) degrees 77° 26 ft.

Rotor Spacing

Distance between centerline of rotors 39 ft.2 in.

Height

*Over Rotor Blades at Rest (Dephased) 18 ft.7.1 in.

Sail area (cross section area of
aircraft at butt line zero) 487 sq. ft.

Sail Area Centroid Sta. 367.5
W.L. 28.6

*For carrier based helicopters, the overall height can be
17 feet for hangar deck stowage when a kneeling kit is pro-
vided.

Rotor Blade Clearance**

(Ground to tip, forward rotor, static) 7 ft. 6.7 in.
(Ground to tip, rotors turning) 11 ft. 0.9 in.
(L.E. of aft pylon to forward rotor
blade tip, rotor blades static) 16.7 in.
(L.E. of aft pylon to forward rotor
blade tip, rotor turning) 40 in.
Elevation of aft rotor over forward
rotor (at hub) 4.0 in.

**Controls in neutral is defined by the following character-
istics: (1) The thrust level (collective pitch control) is
in the full down position: (2) The control stick (longi-
tudinal control) is in the center travel position as indicated
by the zero reading on the stick position indicator (stick
travels forward and aft); (3) The control stick (lateral con-
trol) is in the center travel position (equal-side by side,
left and right pedals travel forward and aft); the DCP trim
wheel (stick positioner) is in the zero trim position.

Rotor Data

Rotor RPM (normal and military power)	230 - 250
Rotor RPM (maximum autorotation)	261
Power Loading at Alternate Design	
Gross Weight (46,000/6090)	7.55 lb/HP
Tip Speed - Normal (245 rotor RPM)	769 fps
Thrust Coefficient (245 RPM, S.L. Std., 33,000 lb)	.00415
Blade Droop Stop Angle (ECP 563)	Fwd 4 3/4° Aft 1 1/2° (ECP 563)

Blade Twist (center line of rotor to tip) 9° 14 ft.

Angle of Line Through Center of Gravity and Ground Contact
Point of Forward Wheel Tire to Vertical Line

Reference line level, static deflection of 1W (side elevation) degrees.	45°
---	-----

Maximum Slope Helicopter Can be Parked Upon Without
Overturning

Nose, uphill and most aft center of gravity, degrees	62° 30 ft.
---	------------

Critical Turnover Angle

Normal C.G. with aft wheel swiveled inboard	51° 12 ft.
Weight Empty C.G. with aft wheel swiveled inboard	60° 19 ft.

Rotor Diameter

Span, Rotor Blade Extended	60 ft.
Number of Blades, Each Rotor	3
Geometric Disc Loading (Based on 46,000#)	8.13 lb/ft. ²
Airfoil Section Designation and Thickness Boeing-Vertol Drawing T114R1556	B-V 23010-1.58
Aerodynamic Chord Length, Root and Tip	25.25 in.

Width

Rotor Blades Folded	12 ft. 5 in.
Rotor Blades Turning	60 ft.

Length

Maximum	
Rotor Blades Turning (parallel to static ground line)	99 ft.

Maximum	
Rotor Blades Folded	51 ft.

Estimated Rotor Blade and Corresponding Blade Control Movements

Collective Pitch

Blade Motion	1° to 18°
Collective Pitch Lever Travel	9.15 in.

Directional Control (Yawing)

Differential Lateral Cyclic Blade Pitch	11.43° right 11.43° left
---	-----------------------------

Directional Pedal	3.60 in. forward 3.60 in. aft
-------------------	----------------------------------

Longitudinal Control (Pitching)

Differential Collective Blade Pitch	4° plus 4° minus
Stick Control Movement	6.5 in. forward 6.5 in. aft

Lateral Control (Rolling)

Lateral Cyclic Blade Pitch	8.0° left 8.0° right
----------------------------	-------------------------

Stick Control Movement	4.18 in. right 4.18 in. left
Maximum Simultaneous Directional Plus Lateral Control	16.5° fwd. rotor 16.5° aft rotor

Trim Controls

Stick Trim

Differential Collective Blade Pitch	1° plus 1° minus
-------------------------------------	---------------------

Speed Trim

Automatic as a function of forward speed as required.
(Reference 114-TN-601, Revision A & ECPs 571, 575, 598,
and 611)

WEAPON PARAMETERS

Reference 14 contains detailed data on the XM204, 105mm Howitzer. The following data has been extracted from Reference 14 and was used as the basic weapon parameter for this study.

XM204, 105mm Howitzer Parameters

Description

a. General - The XM205 105mm Howitzer is the first towed artillery weapon which uses the Soft (Fire-Out-Of-Battery) Recoil Cycle. This weapon differs in appearance from conventional artillery weapons in that it has a single trail extending forward under the tube and no trails extending to the rear, Figure 60. The weapon is traversed and elevated by handwheels located on the side of the carriage. A 6,400 mils traverse capability is provided as the carriage pivots around the center of a circular base by means of a roller device located at the end of the trail. The elevating system is of extending ball screw type, with concentric mechanical springs for equilibration, and provides an elevation range of from -89 to +1333 mils. This weapon is capable of being air lifted in

1.1

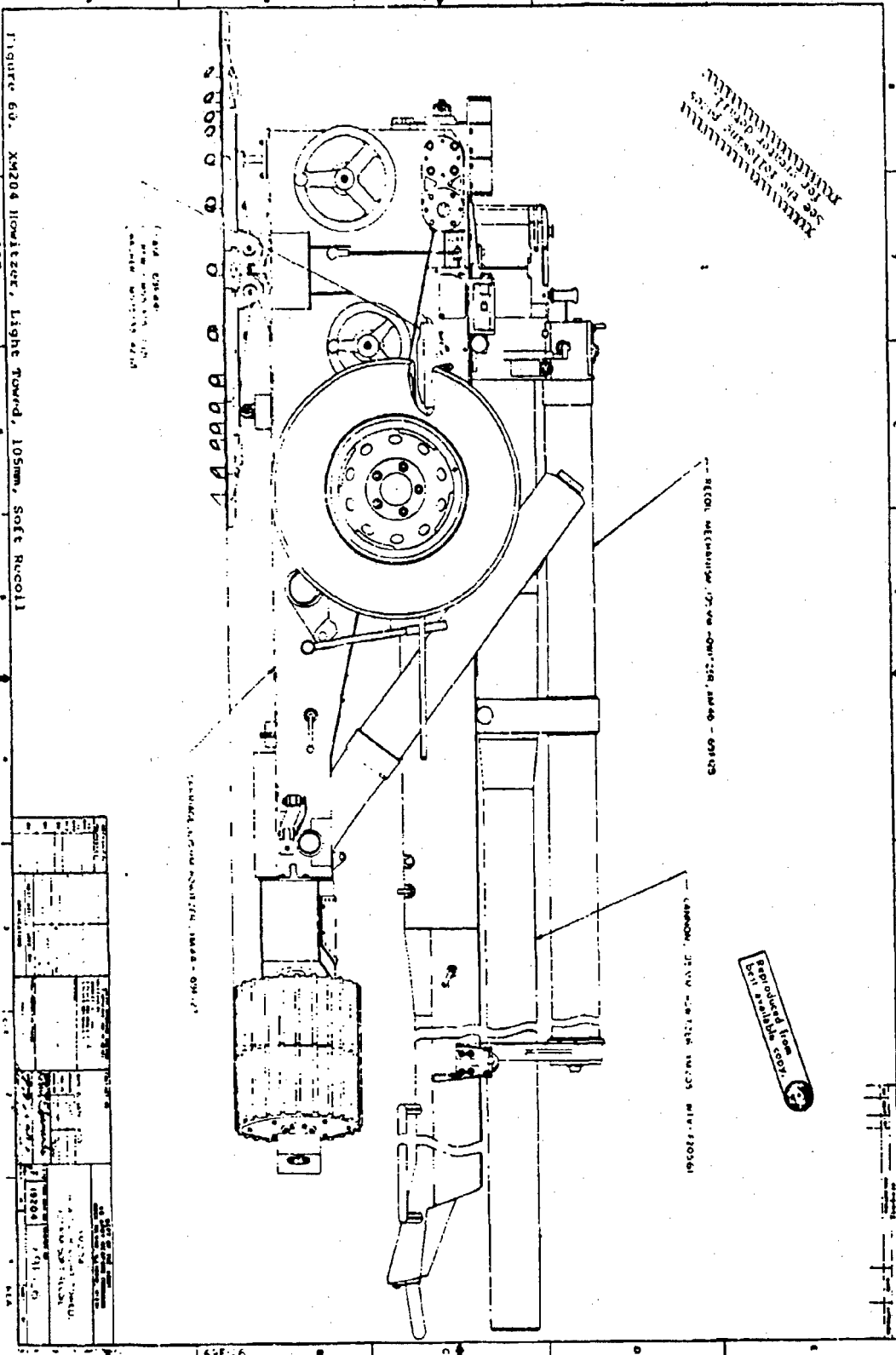
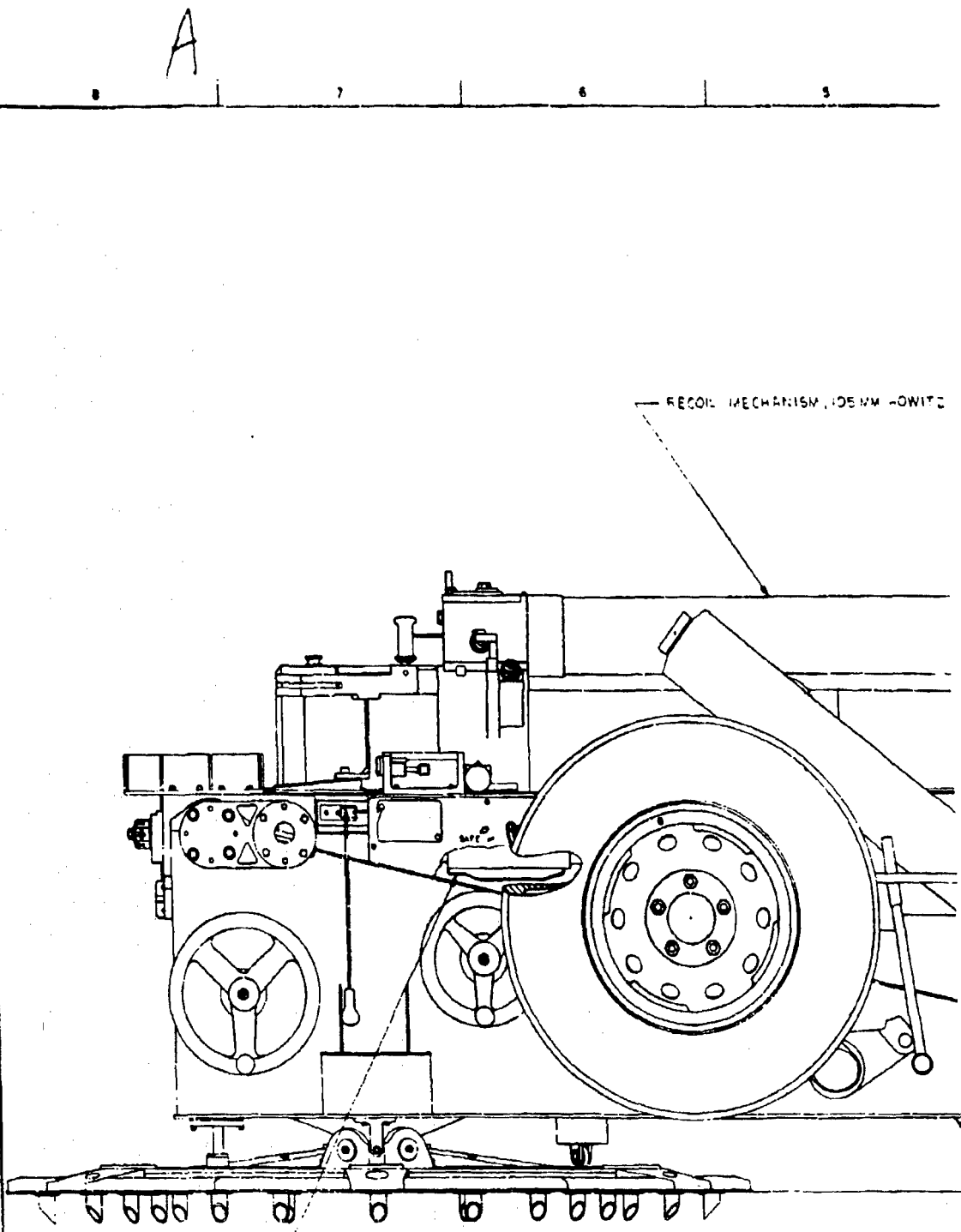

FIGURE 60. XM204 Howitzer, Light Towed, 105mm, Soft Recoil

127

1	2	3	4	5	6	7	8	9	10	11	12	13	14	15	16	17	18	19	20	21	22	23	24	25	26	27	28	29	30	31	32	33	34	35	36	37	38	39	40	41	42	43	44	45	46	47	48	49	50	51	52	53	54	55	56	57	58	59	60	61	62	63	64	65	66	67	68	69	70	71	72	73	74	75	76	77	78	79	80	81	82	83	84	85	86	87	88	89	90	91	92	93	94	95	96	97	98	99	100
---	---	---	---	---	---	---	---	---	----	----	----	----	----	----	----	----	----	----	----	----	----	----	----	----	----	----	----	----	----	----	----	----	----	----	----	----	----	----	----	----	----	----	----	----	----	----	----	----	----	----	----	----	----	----	----	----	----	----	----	----	----	----	----	----	----	----	----	----	----	----	----	----	----	----	----	----	----	----	----	----	----	----	----	----	----	----	----	----	----	----	----	----	----	----	----	----	----	----	-----

1.2



TEAM - 63F401
 CREW - M55-975-17 (2)
 MOUNT - M53-33-42 (2)

Figure 60. XM204 Howitzer, Light Towed, 105mm, Soft Recoil

Reproduced from
best available copy.

ER, XM46 - 69F123

CANNON, 105 MM HOWITZER, XM205 - WTV - F20561

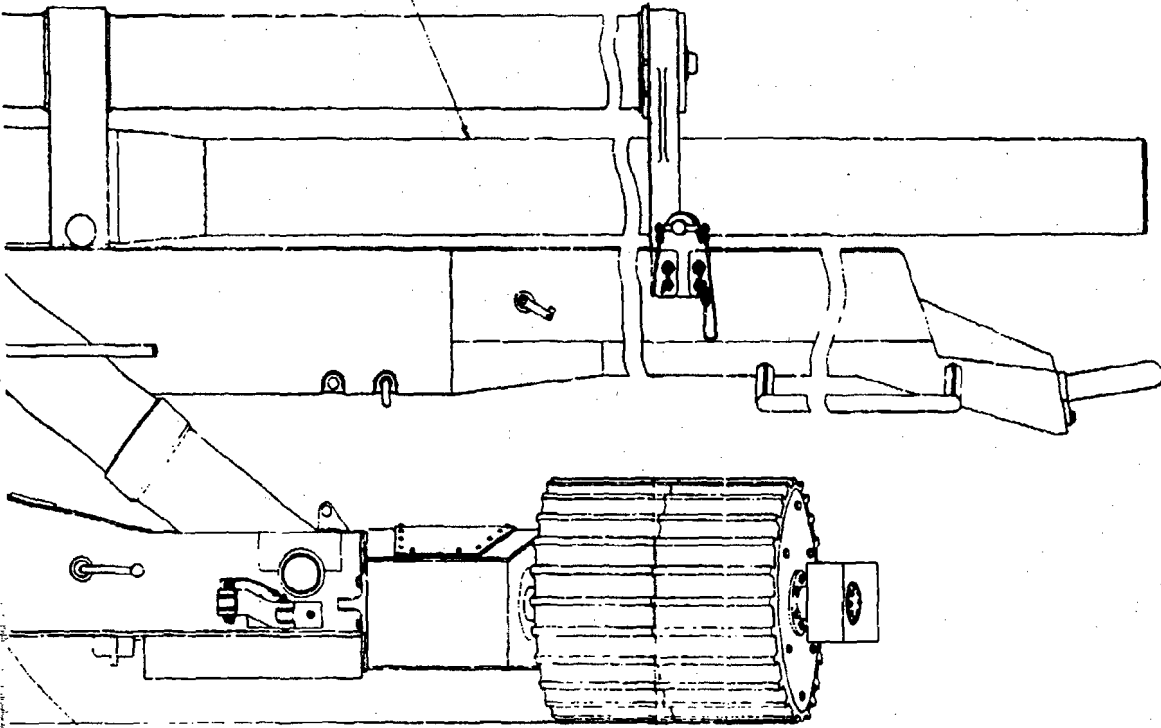

CARRIAGE, 105 MM HOWITZER, XM44 - 69F127

69F126

MECHANICAL PROPERTIES		MATERIAL SPECIFICATIONS		CONTRACT NO.		COPY OF THE ARMY US ARMY WEAPONS COMMAND ROCK ISLAND, ILLINOIS, 61204	
ST		TOLERANCES		DATE	6 JAN 370	XM204	
EN		FINISH		PREPARED	ERP	HOWITZER LIGHT TOWED, 105 MM SOFT RECOIL	
DR		WEIGHT		ENGINEER		19204 69F126	
SA		APPROVAL		DESIGNED BY			
MA		TEST ASST	USED ON	APPROVED BY	<i>J.M. Edwards</i>		
SP		APPLICATION		DATE			

C-2

2

1 REA

112

addition to being towed at speeds up to 35 mph over hard-surface roads.

This weapon utilizes the soft-recoil cycle to achieve its reduced size and weight while still maintaining good firing stability. Staking is not required for most soil conditions.

The XM204 Howitzer (69F126) is composed of an XM44 Carriage, an XM46 Recoil Mechanism, an XM205 Cannon and the required fire control equipment. These major components are described in detail in the paragraphs that follow.

Figure 60 is a side view drawing showing a general overview of the XM204 Howitzer Light Towed, 105mm Soft Recoil.

b. XM44 Carriage (69F127) - The XM44 Carriage mounts the cannon and recoil mechanism and provides the means of transporting and emplacing the weapon. The carriage is composed of a welded box section undercarriage, a traversing beam assembly, a cradle and buffer assembly, an elevating mechanism, a suspension system and a firing base. These components are described in the paragraphs that follow:

(1) Carriage (69F665): The undercarriage is basically an aluminum box frame construction. Triangular shaped boxed sides provide the required carriage stiffness. This welded structure is composed of three major sections. The breech end contains the trunnions, the firing base connection, the handwheel locations, and a compartment for tools and accessories. The center section contains all the suspension connections and the muzzle end contains the traversing and elevating component connections. The muzzle section also provides the connecting point for the cradle travel lock.

(2) Traversing Beam Assembly (69F161): The forward part of the traversing mechanism is called the walking beam. This assembly is a boxed H-shaped beam with a fixed pintle which allows it to rotate 20° total displacement perpendicular to the ground. The walking beam consists of an H-frame, a pair of rubber treaded aluminum rollers, splined shafts, U-joints and drive chains. The 15 in. diameter rollers are driven by splined shafts and U-joints with the chains from a central drive shaft through the pintle into the carriage traverse drive.

Tabulated Data

Weights

Complete Weapon	3,615 lb.
30 in. Barrel Extension	136 lb.
Carriage XM44	1,973 lb.
Recoil Mechanism XM46	505 lb.
Cannon XM205	1,137 lb.

Dimensions (Travel Condition)

Length	14 ft. 10 in.
Width	6 ft. 6 in.
Height	5 ft. 10 in.
Ground Clearance	12 in.
Tread	5 ft. 10 in.
Center of Gravity	8 ft. 4 in. behind center of lunette

Lunette Load

225 lb. at 29 in.
high

Tires

Size

7:00 x 16, 6 ply

Pressure:

Transport
Tactical

45 psi
20 psi

Angle of Departure

26 degrees

Elevation Range

-89 mils to
+1333 mils

Traverse Range

Full 6400 mils

Prime Mover

3/4 ton 4 x 4
truck

Maximum Towing Speed

Cross Country	10 mph
Improved Roads	35 mph

Brakes	Hand Operating
--------	----------------

Type of Firing Mechanism	Continuous Pull
--------------------------	-----------------

Rate of Fire

Maximum	10 rds per min for 3 minutes
---------	---------------------------------

Sustained	3 rds per min
-----------	---------------

Handwheel Loads	10 lb. (approx)
-----------------	-----------------

Mils of Movement per Turn of Handwheel

Elevation	10 (approx)
-----------	-------------

Traverse	10 (approx)
----------	-------------

**TABLE XI. ENGINE CHARACTERISTICS AND WEIGHT
AND PERFORMANCE CRITERIA**

		<u>CH-47C</u>
<u>Engine Characteristics</u>		
Maximum Rating	(shaft HP)	3,750
Military Rating	(shaft HP)	3,400
Normal Rating	(shaft HP)	3,000
<u>Weights</u>		
Design Gross Weight	(lb)	33,000
	(kg)	14,969
Alternate Gross Weight (1)	(lb)	46,000
	(kg)	20,856
Empty Weight	(lb)	20,378
	(kg)	9,243
Payload Capability	(alternate GW)	
- 10 nautical miles	(lb)	24,100
18.5 kilometers	(kg)	10,931
- 100 nautical miles	(lb)	19,800
185 kilometers	(kg)	8,981
- Full Fuel	(lb/NM)	17,300/149
	(kg/km)	7,847/276
<u>Performance (33,000 Pounds Gross Weight, Standard Atmosphere)</u>		
Hover Ceiling - Out of Ground Effect	(ft)	14,700
	(meters)	4,481
Maximum Power		
Forward Rate of Climb	(ft/min)	2,880
(Sea Level/Normal Rated Power)	(meters/sec)	14.63
Service Ceiling - Two Engines	(ft)	15,000
(Normal Rated Power)	(meters)	4,572
Speed Capability	(kt)	165
(Sea Level/Normal Rated Power)	(km/hr)	306
(1) Excludes troop seats, supports, and engine inlet screens		
(2) Envelope established by current flight test program		

APPENDIX II

DESIGN CRITERIA AND LOADS

This appendix presents the design criteria and applied loads due to howitzer recoil, blast pressure, crash and maneuver loads which were used for design. Functional design criteria are also presented.

STRUCTURAL DESIGN CRITERIA

The structural design criteria established herein are in compliance with AR-56 military requirements and special CH-47 design limitations. These criteria will be used for sizing redesigned airframe structure for the weapons kit and to evaluate the present aircraft structural integrity and feasibility for a howitzer-mounted CH-47C.

PHYSICAL PROPERTIES OF MATERIALS

The physical properties of materials used in the design will be in accordance with MIL-HDBK-5.

FACTORS OF SAFETY

Yield factor of safety = 1.0; alternate factor of safety = 1.5.

FLIGHT AND LANDING RESTRICTIONS

<u>Item</u>	<u>Minimum Flight Gross Weight</u>	<u>Alternate Gross Weight</u>
Gross Weight, lb	35,000 (33,000 test data)	46,000
Flight Maneuver Load Factors at CG, g (Limit)	3.0 -.5	2.3 -.5
Sinking Speed for Landing, fps (Limit)	8.2	designed and demonstrated

Slope landings to the right or left must not exceed 15 degrees.

EXTERNAL HOWITZER HOIST

Maneuver load factor = 3.0 g's (vertically). Sway or coning angle = 15 degrees in any quadrant.

CRASH LOADS CRITERIA

Eight g's down (vertically)

Eight g's forward (longitudinally) Acting separately

Eight g's side (laterally)

CARGO COMPARTMENT FLOOR

1. Internal cargo and ordinance shall not exceed a uniform floor loading of 300 psf.
2. Concentrated loads in the cargo area shall not exceed 2,500 pounds for the treadway, 1,000 pounds for the floor.

DRIVE SYSTEM

The torque split will not exceed 60 percent on either rotor.

FATIGUE DESIGN CONDITIONS

Dynamic Components

A representative aircraft mission profile is required to re-evaluate component lives. These lives should not be degraded from the standard CH-47C component fatigue lives as a result of the incorporation of the weapons.

Howitzer Attaching Hardware

The attaching structure will be designed for an unlimited life.

APPLIED LOADS

The weapon installation generates loads due to firing the weapons and the accelerations caused by maneuvering the helicopter and by crashing. These applied loads multiplied by the appropriate factors result in limit and ultimate loads. Firing the weapons produces muzzle blast loads and recoil loads. Blast loads have been calculated based on the pressure isobars with consideration for blast pressure reflections. These blast loads are presented in this report in the section where the loads data are required. Recoil loads for the XM204 howitzer were obtained from RIA and are summarized in Table XII. A distribution of these recoil loads may be useful in subsequent studies where fatigue due to firing is addressed. The distribution in Table XIII is suggested for this purpose.

DESIGN LIMIT LOADS

Design limit loads are the maximum loads anticipated to be

TABLE XII. DESIGN RECOIL LIMIT LOADS CRITERIA			
	Condition	Design Load Magnitude lb/direction	Frequency of Occurrence
Normal Operations Inflight	Zone 5, no impulse generator	7,000 aft	5,000 firings from each weapon
Normal Operations on Ground	Attached firing, all zones and elevations except zone 8 at 75°	7,000 distributed in elevation, azimuth and charge as shown in Table XIII 13,000	5,000 firings
Malfunctions Inflight	Zone 8 with velocity Sensor for zone 5 misfire Zone 5 from latch (cookoff)	36,500 aft 19,500 forward 16,000 aft	1 per weapon 1 per weapon
Malfunctions Ground	Zone 8 with velocity Sensor set for zone 5 misfire Zone 5 from latch	36,500 recoil 19,500 counter-recoil 16,000 recoil	The mounting shall be designed for one of each failure with the weapon at any azimuth and elevation within its available travel

TABLE XIII. DISTRIBUTION OF GROUND FIRING CONDITIONS TO BE USED FOR RIGHT-SIDE HOWITZER											
ELEVATION (DEGREES)	PERCENT OF ALL FIRING AT AZIMUTH ANGLES (DEGREES)									TOTAL FOR ALL AZIMUTHS	
	0	45	60	75	90	105	120	135	180		
10	0	0	0	1	1	1	1	0	0	0	3
20	0	0	1	1	1	1	1	0	0	0	5
30	0	0	1	1	1	1	1	0	0	0	5
45	2	5	5	10	30	10	5	5	2	2	74
60	0	0	1	2	4	2	1	0	0	0	10
70	0	0	0	0	3	0	0	0	0	0	3
TOTALS FOR ALL ELEVATIONS	2	5	8	15	40	15	8	5	2		

Charge zones for ground firing will be assumed to be distributed as:

ZONE	PERCENT OF ALL ROUNDS FIRED
8	60
7	20
6	10
5	5
4 or less	5

applied on the helicopter during its lifetime of operation. The helicopter structure shall be capable of supporting these limit loads without suffering detrimental permanent deformation. For the weapon installation, the design limit loads are based on 3g maneuver loads and the recoil applied loads as shown in Table XIV. The various components of these loads as applied to the weapon support structure are shown in Table XV.

ULTIMATE DESIGN LOADS

Ultimate design loads are the limit design loads multiplied by a 1.5 factor of safety. Ultimate loads for the fuselage attachments are shown in Table XVI with comparable ultimate design loads for the forward main landing gear beam. This comparison shows that the howitzer installation causes loads which are about twice the landing gear loads.

FUNCTIONAL DESIGN CRITERIA

To ensure functional compatibility of the XM204 weapons and CH-47C aircraft, design criteria for each of these major components were separately formulated and then integrated to produce the system criteria for the study configuration.

The following itemizes those installation design considerations important to the safe, efficient operation of the XM204 weapon:

1. Provide a level, secure foundation for the weapon firing base and walking beam assembly.
2. Prevent exposure to damaging vibration or loads which would adversely affect the fatigue service life of the weapon.
3. Protect the weapon against deterioration due to constant exposure to climatic conditions.
4. Provide for ease of weapon servicing maintenance and repair.
5. Provide space for crew stations for manual operation of the weapon.
6. Provide for ease of handloading (nearest obstruction behind breech shall be no closer than 40 inches).
7. Provide means for boresighting the weapon.

The following are the external loading considerations which have been developed to ensure the safe operation of the aircraft:

TABLE XIV. DESIGN LIMIT LOADS

Flight Conditions	No.	Howitzer Charge Conditions	Design Recoil Load From Table I, lb		Design Load Factor g		
			P _L	P _R	n _z	n _x	n _y
			Inflight Normal		Acting together Zone 5	+7000	+7000
		Acting separately Zone 5	+7000	0	3.0	1.0	1.0
		Acting separately Zone 5	0	+7000	3.0	1.0	1.0
Inflight Malfunctions		Zone 5, Cookoff	+16000	0	3.0	1.0	1.0
		Zone 5, Cookoff	0	+16000	3.0	1.0	1.0
		Misfire	-19500	0	3.0	1.0	1.0
		Misfire	0	-19500	3.0	1.0	1.0
		Zone 8, Velocity Sensor Set at Zone 5	36500	0	3.0	1.0	1.0
		Zone 8 Velocity Sensor Set at Zone 5	0	36500	3.0	1.0	1.0
Ground Operations Normal	10	All Firing Zones & Elev. Except Zone 8 at 75°	0	+7000	1.0	1.0	1.0
	11	Firing Zone 8 at 75°	0	+13000	1.0	1.0	1.0
Ground Operation Malfunction	12	Zone 8 with Velocity Sensor at Zone 5	0	+36500	1.0	1.0	1.0
	13	Misfire	0	-19500	1.0	1.0	1.0
	14	Zone 5, Cookoff	0	+16000	1.0	1.0	1.0
Crash 1	15	No Gun Firing	0	0	8.0	8.0	8.0

- Notes: 1 Load factors are for ult. condition acting separately in each direction.
 2 Double failures are not considered as a design condition

H_{ZL} = Port Howitzer Weight = 3571 Lbs.
 H_{ZR} = Starboard Howitzer Weight = 3200 lbs.

TABLE XV. CRITICAL DESIGN LIMIT AND ULTIMATE LOADS

CONDIT. ON NO FROM TABLE XIV	GUN FIRING AZIMUTH & ALTITUDE POSITION DEG	LIMIT DESIGN LOADS - LBS						ULTIMATE DESIGN LOADS - LBS					
		GUN RECOIL LOAD		GUN RECOIL LOADS IN X Y Z AXIS		HOWITZER WT		GUN RECOIL LOADS IN X Y Z AXIS		HOWITZER WT			
		P _L	P _R	P _V	P _X	P _Z	M _R	M _{ZL}	P _V	P _X	P _Z	M _{ZR}	M _{ZL}
9	0.0	0	36 500	0	36 500	0	3 675	-3 571	0	54 900	0	16 600	16 000
12 a	0.0	0	36 500	0	36 500	0	4 475	-3 571	0	54 900	0	6 700	5 350
17 a	0.75°	0	36 500	0	36 500	35 200	4 475	-3 571	0	14 200	52 900	6 700	5 350
12 c	90° 0	0	36 500	36 500	0	0	4 475	-3 571	54 900	0	0	6 700	5 350
12 d	90° 75°	0	36 500	9 450	0	35 200	-4 475	3 571	14 200	0	52 900	6 700	5 350

NOTES 723
 STARBOARD GUN FIRING WILL SIZE BEAM SUPPORT STRUCTURE

WT INCLUDES 3 200 LB HOWITZER - 475 LB PLATFORM

WT INCLUDES 3 200 LB HOWITZER - 475 LB PLATFORM - C L 800 LB MEN

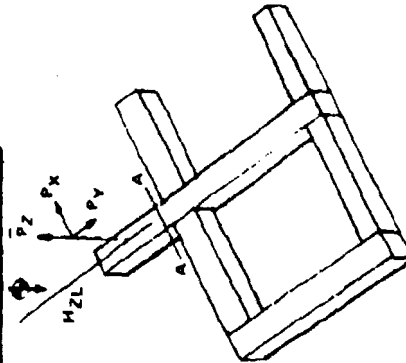

CONDITIONS
12 c, 12 d

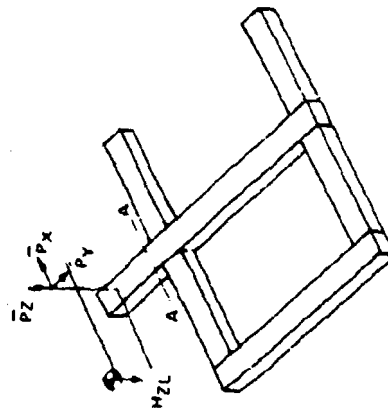

CONDITIONS
9, 12 a, 12 b

TABLE XVI.

ULTIMATE DESIGN LOAD SUMMARY - LBS

	FWD MAIN LANDING GEAR BEAM RH AND LH SIDES STA 260 TO 240	HOWITZER SUPPORT BEAM		
		STA 320 TO 300 AFT BEAM		STA 210 TO 230 FWD BEAM
		RH SIDE	LH SIDE	LH SIDE
VERT	34,500	52,900	17,100	11,400
DRAG	19,900	54,900	33,000	22,000
SIDE	16,700	54,900	17,100	11,400

- NOTES: 1. THE ULTIMATE LOADS SHOWN ABOVE DO NOT NECESSARILY ACT TOGETHER, EACH LOAD REPRESENTS THE MAXIMUM IN ITS RESPECTIVE DIRECTION.
 2. FWD MAIN LANDING GEAR ULTIMATE LOADS WERE EXTRACTED FROM REF. NO. 18

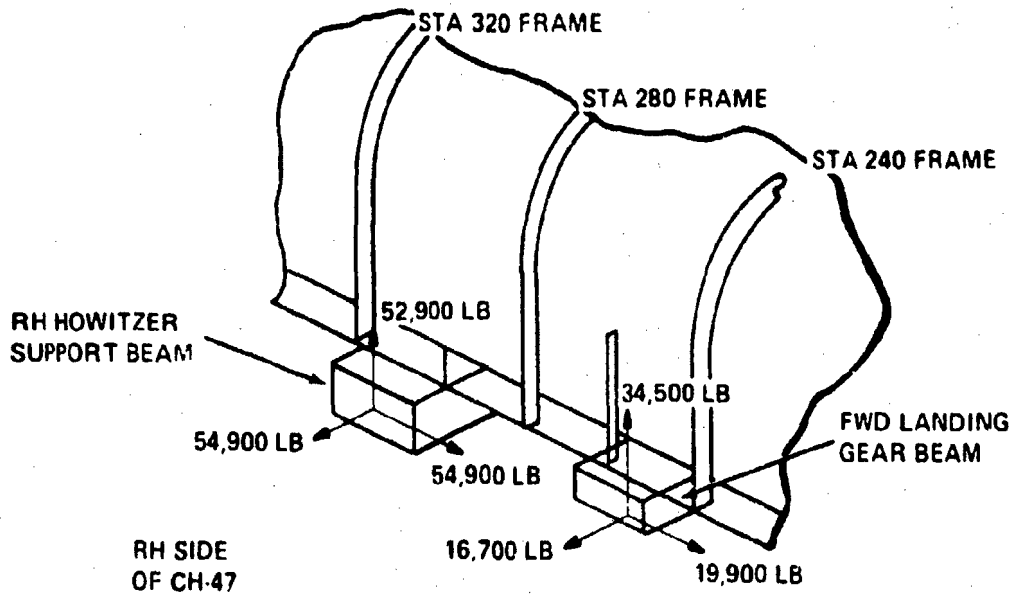

1. Total loading (including externally-mounted equipment) shall not exceed the alternate gross weight of the aircraft.
2. Externally-mounted objects shall be adequately secure to prevent them coming off in flight and damaging the rotor system.
3. Static and dynamic (recoil) loads from externally-mounted equipment must be reacted without detrimental effect on the airframe structure.
4. Externally-mounted loads must not change airframe vibration natural frequency to such an extent as to result in premature fatigue failure of components.
5. Emergency jettison provisions shall be included for external loads suspended from the aircraft on cables.
6. External loads must not contribute excessive rotor downwash frontal area which would result in excessive hover download.
7. Drag increase due to the weapons must not seriously disrupt aircraft performance or controllability.

APPENDIX III

REQUIREMENTS FOR THE STRUCTURAL TEST PROGRAM

In this appendix, a first cut has been taken to define the structural test program required to ensure that the weapons installation is adequate. This outline should be expanded as more details become known.

STATIC TEST OF WEAPON INSTALLATION TO LIMIT LOADS

Test the howitzer attaching hardware as mounted on a CH-47C fuselage at limit load under design operating conditions. The test static limit load is 36,500 pounds on the right-hand side acting at any azimuth position and altitude. Strain gauge the howitzer attaching hardware and fuselage at critical locations. Success is defined by no yielding of the aircraft structure at limit load. Spring rates of the mounting structure should be measured during loadings to check the vibration dynamics analyses.

WEAPON FIRING GROUND TESTING

Limit load test the forward fuselage skin, doubler, stringers, and frames during a zone 8 charge blast with the weapon's muzzle in the in-flight mode parallel to the fuselage longitudinal axis. The test should be performed with rotors operating at 100-percent rpm. Six weapon firings is a minimum requirement.

Strain gauge the rotor blades, controls, forward fuselage skin, frames and doubler. Gauge response time should be capable of recording the peak overstress lasting approximately .1 to .8 milliseconds. Success is defined by no yielding of the aircraft structure for a zone 8 charge.

Monitor peak fuselage acceleration airframe locations selected by the Dynamics group. A major concern is the vertical, longitudinal and lateral accelerations in the forward cabin area. Various doubler isolation designs may be experimented with to optimize the vibration environment for airframe fatigue and crew comfort.

Acoustical measurements in the forward and aft fuselage should be measured to determine the noise levels during firing to see if further acoustic treatment is necessary.

COMPONENT VIBRATION TESTING

All components of the weapons installation must be tested to ensure that helicopter vibration will not cause fatigue

failures. Vibration shake tests will be conducted on all components including the howitzers with accelerations and frequencies to be Boeing-Vertol specifications. Components that could cause the firing of the weapons to hit the helicopter need particular attention.

FLIGHT TESTING INCLUDING WEAPON FIRING

Conduct a flight test program to determine dynamic component loads, airframe loads, and airframe vibrations during level flight including firing of a zone 5 charge with each howitzer. Determine lateral cg limits based on structural or control limits, whichever is less, with the left-side howitzer detached and unloaded. Also, record steady and vibratory stress and vibration data for rotor blades, controls and rotor shaft.

APPENDIX IV
STRESS ANALYSIS

In this appendix, the detail stress calculations used to size the structure of the weapons kit and the hardpoints provisions are presented. Results of a reevaluation of the dynamic component fatigue lives which consider the continuous high gross weight operation of the aerial artillery mission are also presented. Detail calculation of rotor blade stresses that show that muzzle blast loads can be accommodated without modification is presented.

DYNAMIC COMPONENT FATIGUE EVALUATION

Incorporation of the weapons kit on the CH-47C helicopter will have a consequential effect on the assumed aircraft mission profile and dynamic system component vibratory loads and life. A simplified fatigue evaluation relating aircraft usage (mission profile), structural envelope, and fatigue loads is presented.

The current CH-47C mission profile used in establishing component lives, as reported in Reference 15, is shown in Table XVII. The AAWS CH-47C mission profile, Table XVIII, was constructed by coordinating appropriate field experience (Reference 16), military requirements (Reference 17), and configuration design requirements. The major differences between the current CH-47C profile and AAWS CH-47C profile are:

- Time spent at normal and alternate gross weights
- Time spent in the forward CG position
- Time spent from 0-6000 (H_D) density altitude
- Time spent in a lateral CG position

The first two items may have an adverse effect on forward dynamic component fatigue lives. The third item should enhance forward and aft component fatigue lives. The effects of lateral CG position on dynamic component fatigue loading is uncertain with the exception of vibratory rotor shaft bending moments which will increase above the 0.0 lateral CG position vibratory shaft bending moments.

The maximum forward airspeed V_H (maximum airspeed attainable using the lower of military rated power or the structural limit V_{ne}) for the basic CH-47C and the modified AAWS CH-47C is shown in Figure 61. As noted in the figure, the AAWS-configured CH-47C maximum airspeed (V_H) at 35,000 pounds gross weight is

TABLE XVII. BASIC CH-47C FATIGUE LOADING SCHEDULE

Gross Weight (lb)	Per-cent Time	RPM Split	CG Split	Aft Split	Cargo Split	Flight Condition	Occurrence
27,000	50	100% at 235-245 rpm	100% at normal CG	50% <6,000' 40% 6-10,000' 10% >10,000'	None	<u>Level Flight</u> Hover Transition 60% Vne 90% Vne 100% VH 110% VH <u>Maneuvers</u> Landing Flare Turn Pullup Lateral Rev Long Rev Dir Rev	10% 15% 25% 20% 20% 10% 4/hr 10/hr 4/hr 4/hr 4/hr
33,000	25	Same as 27,000 lb GW	50% fwd CG; 50% aft CG	Same as 27,000 lb GW	None	Same as 27,000 lb GW	Same as 27,000 lb GW
46,000	25	100% at nominal 245 rpm	Sec cargo split	50% <6,000' 50% ≥6,000" (internal cargo only)	75% w/external cargo at aft CG, TAS <6,000', VH = 100 kt 25% w/internal cargo 50% at fwd CG 50% at aft CG	Same as 27,000 lb GW	Same as 27,000 lb GW

TABLE XVIII. CH-47C AAWS FATIGUE LOADING SCHEDULE							
Gross Weight (lb)	Percent Time	RPM Split	CG Split	Aft Split	Carg. Split	Flight Condition	Occurrence
33,000 Right Howitzer Only	10	100% at 235-245 rpm	100% at neutral or forward longitudi- nal CG, 18"R lateral CG	90% <6,000' 10% <6,000'	None	<u>Level Flight</u> Hover Transition 60% VH 90% VH 100% VH 110% VH <u>Maneuvers</u> Landing Flare Turn Pullup Lateral Rev Longitudinal Rev Directional Rev	10% 15% 25% 20% 20% 10%
35,000 Left & Right Howitzers, Minimum Flight Weight	40	Same as 33,000 lb GW above	100% at forward CG	90% <6,000' 10% <6,000'	None	Same as 33,000 lb GW above	Same as 33,000 lb GW above
46,000 Alternate GW	50	100% at normal 245 rpm	100% at forward CG	90% <6,000' 10% <6,000'	None	Same as 33,000 lb GW above	Same as 33,000 lb GW above

BASIC CH-47C

GW = 35,000 LB
N_r = 235 RPM

GW = 46,000 LB
N_r = 245 RPM

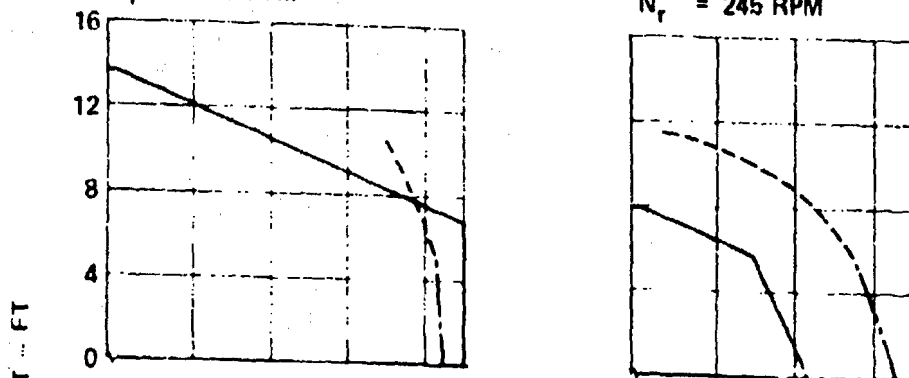

AAWS CH-47C

GW = 35,000 LB
N_r = 235 RPM

— VNE
 - - - XMSN LIMIT GW = 46,000 LB
 - - - MIL POWER N_r = 245 RPM

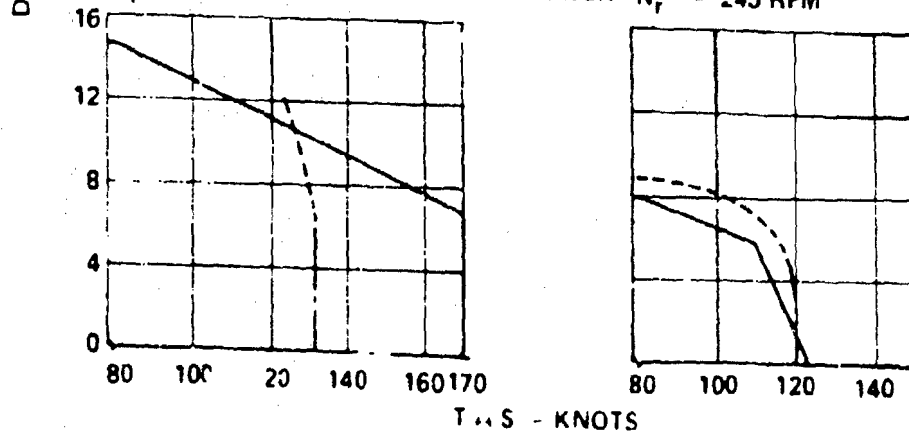

Figure 61. CH-47C Structural and Power Flight Limitations For STD

approximately 33 knots slower than the basic CH-47C. As a result, fatigue damage at 35,000 pounds gross weight in the AAWS configuration will be negligible. Maximum airspeed (V_H) at 46,000 pounds gross weight is essentially the same for the basic CH-47C configuration and the AAWS configuration.

Longitudinal CG limits are within the flight manual limits (Figure 36); lateral CG structural limits have not been established at this time.

CONCLUSION

The following assumptions are made concerning fatigue damage for the AAWS configuration:

1. Forward dynamic system component fatigue damage at 46,000 pounds gross weight - level flight will double in the AAWS configuration from that published in Reference 19.
2. Forward dynamic system component vibratory loads during gun firing are assumed nearly equivalent to loads prior to firing.
3. No fatigue damage at 35,000 pounds and below to either the forward or aft dynamic component.
4. The entire aircraft life is spent in the AAWS configuration.
5. Possible fatigue damage incurred during operations at the extreme lateral CG position is negligible due to low occurrence.

Table XIX lists the CH-47C dynamic component lives that will be reduced when operating in the AAWS configuration. All other component lives will remain as listed in Reference 19.

CH-47C AIRFRAME ULTIMATE STRENGTH

Any redesign or addition to the helicopter structure that alters the original design loads requires an ultimate and fatigue analysis to substantiate the structural integrity of the integrated systems. Reanalysis of the present CH-47C airframe to accommodate two externally-mounted XM204 howitzers is beyond the scope of this study; therefore, only general strengthening requirements are discussed.

The present CH-47C lower fuselage structures are constructed of .020-inch-thick skin, stiffened by honeycomb stringers. Skin and stringer stiffening between stations 160 to 360 will be required to distribute howitzer ultimate design side and drag loads into the fuselage. Frame stiffening between stations 160 and 360 is required to react ultimate design vertical

TABLE XIX. REDUCED FORWARD ROTOR COMPONENT LIVES DUE TO CONTINUOUS HIGH GROSS WEIGHT OPERATIONS OF AERIAL ARTILLERY MISSIONS

P/N	Component	Current Life (hr)	AAWS Life Approx. (hr)
114R1570-1	Forward Rotor Blade Nose Cap Station 100	6,220	3,300
114R1518-1, -2, -3	Forward Rotor Blade Trailing Edge Station 144	12,500	5,800

loads from howitzer recoil, crash conditions, and hoist requirements.

Airframe bending moments and shear diagrams for each critical design condition will be calculated to determine the fuselage stiffness requirements to accommodate the externally-mounted howitzers.

CH-47C AAWS HOWITZER SUPPORT BEAM ANALYSIS

The purpose of this section is to size the howitzer support beam installation as shown in Figure 10. Airframe beef-ups required to incorporate this system will be discussed in another section.

The design criteria as established by the customer and presented in the Boeing-Vertol Progress Report of May 1972 is presented in Tables XII and XIII.

The right-side gun mounting is more critical than the left gun. The selected material and beam cross-section which conforms to the design conditions is shown below.

Summary

Material

4340 HT steel

$F_{tu} = 150,000$ psi

Beam Section

Starboard Side Aft Beam

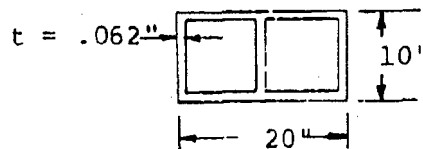

Port Side Aft Beam

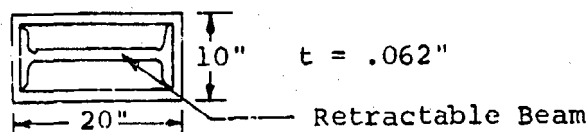

Port Side Fwd Beam

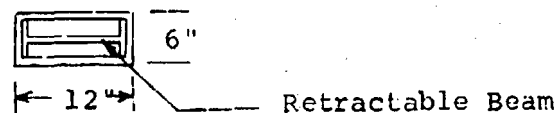

HOWITZER INSTALLATION

Aft lateral beam support sizing (right side); condition #9, Table XIV.

View looking forward:

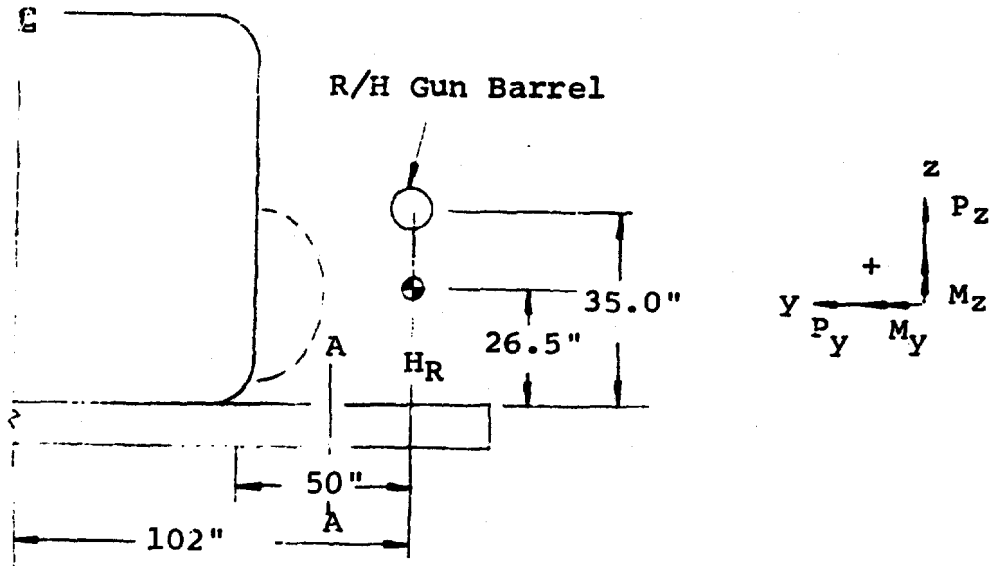

View A-A

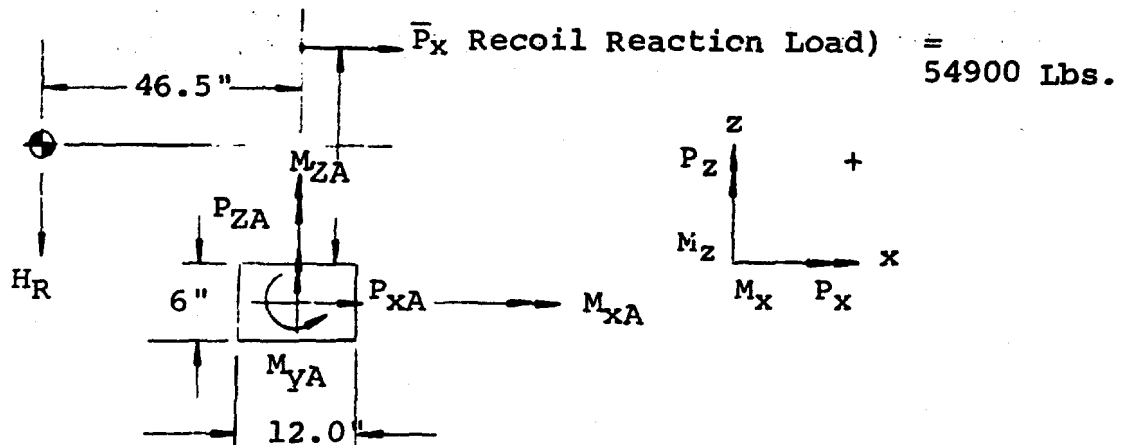

Beam Material: 4340 HT steel from (SDM) Reference 20.

$F_{tu} = 150$ ksi	$S_e = \pm 20,000$ psi nonfretted $R = -1$	} $K_t = 1$
$F_{ty} = 132$ ksi	$S_e = \pm 10,000$ psi fretted $R = -1$	
$F_{cu} = 145$ ksi	$F_{bu} = 222.5$ ksi	
$F_{su} = 95$ ksi	$F_{by} = 165$ ksi	
$E = 29 \times 10^6$ psi		
$G = 11 \times 10^6$ psi		

Condition #9, Table XIV

$$M_{xA} = 0$$

$$M_{yA} = +46.5 \times 16600 - 38 \times 54900 = 0$$

$$M_{yA} = +770,000 - 2,080,000$$

$$M_{yA} = -1,310,000 \text{ in.-lb}$$

$$M_{Az} = -2,745,000 \text{ in.-lb}$$

$$P_{zA} = +16,600 \text{ lb}$$

$$P_{xA} = -54,900 \text{ lb}$$

$$P_{yA} = 0$$

Condition #12.c, Table XIV

$$P_{xA} = 0$$

$$P_{zA} = +6,700 \text{ lb}$$

$$P_{yA} = +54,900 \text{ lb}$$

$$M_{yA} = 0$$

$$M_{xA} = +2,715,000 \text{ in.-lb}$$

$$M_{zA} = 0$$

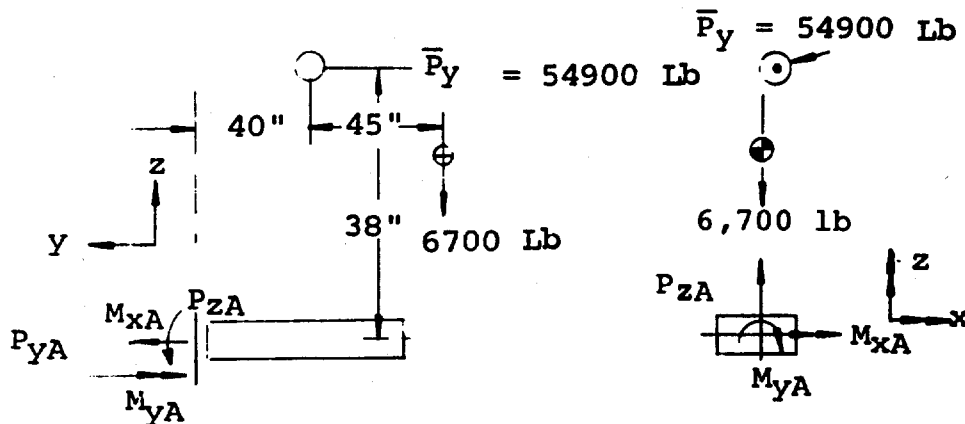

$$+M_{xA} - 6700 \times 95 - 38 \times 54,900 = 0$$

$$M_{xA} = 635,000 + 2,080,000$$

$$M_{xA} = 2,715,000 \text{ in.-lb}$$

Condition #12.d, Table XIV

$$P_{xA} = 0$$

$$P_{yA} = -14,200 \text{ lb}$$

$$P_{zA} = -46,200 \text{ lb}$$

$$M_{xA} = -2,850,000 \text{ in.-lb}$$

$$M_{yA} = 0$$

$$M_{zA} = 0$$

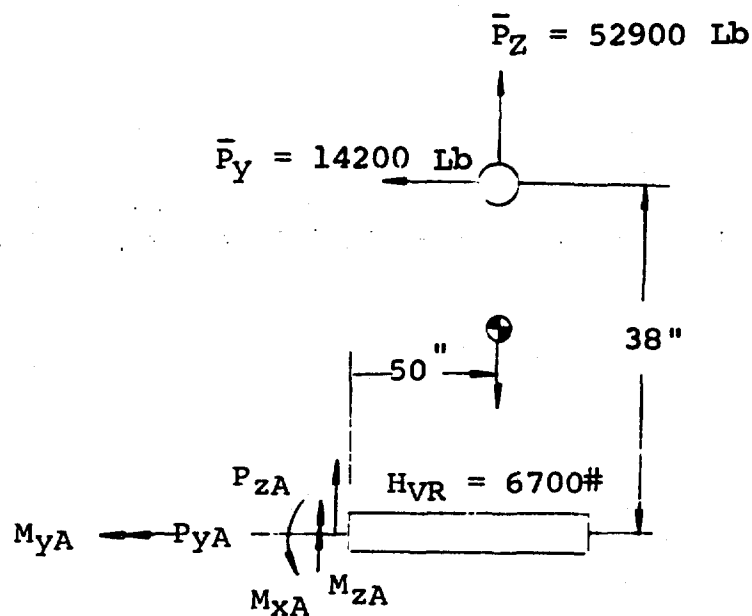

$$P_{zA} + 52,900 - 6700 = 0$$

$$P_{zA} = -46,200 \text{ lb}$$

$$P_{yA} + 14,200 = 0$$

$$P_{yA} = -14,200 \text{ lb}$$

$$M_{xA} - 50 \times 6700 \times 50 \times 52,900$$

$$+ 38 \times 14,200 = 0$$

$$M_{xA} = -2,850,000 \text{ in.-lb}$$

Right-Hand Lateral Support Beam Sizing

Condition	REACTION LOADS						THICKNESS	M.S.
	P_{XA} (LB)	P_{YA} (LB)	P_{ZA} (LB)	M_{XA} x1000 IN-LB.	M_{YA} x1000 In-LB.	M_{ZA} x1000 IN-LB.	t (IN)	
#9	-54900	0	+16600	0	-1310	-2745	.062	+ .40
#12.c	0	+54900	+6700	+2715	0	0	.062	+ .16
#12.d	0	-14200	-46200	-2850	0	0	.062	+ .12

BEAM REACTIONS FOR CRITICAL DESIGN CASES

Right-Hand Side Looking Forward

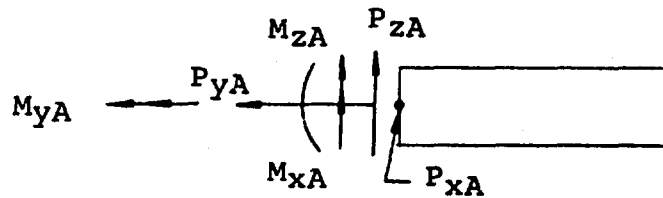

SECTION PROPERTIES OF RIGHT SIDE LATERAL SUPPORT BEAM

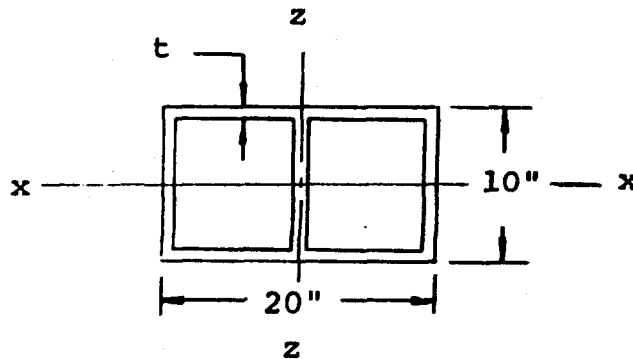

Assume $t = .062$

Area = $20 \times 10 - 19.81 \times 9.88 = 200 - 195.5$

$A = 4.5 \text{ in.}^2$

$$I_x = \frac{1}{12} \times 3 \times .062 \times 9.88^3 \times 2 \times 20 \times .062 \times 4.97^2$$

$$I_x = 14.95 + 61.26 = 76.21 \text{ in.}^4$$

$$I_z = 1 \times 2 \times .062 \times 19.88^3 + 2 \times 10 \times .062 \times 9.97^2$$

$$I_z = 81.19 + 123.26 = 204.45 \text{ in.}^4$$

STRESS ANALYSIS OF BEAM STRUCTURE

Condition #9, Table XIV

$$\tau_{av} = \frac{PzA}{3 \times h \times t} = \frac{16,600}{3 \times 10 \times .062} = 8,800 \text{ psi}$$

$$\tau_{av} = \frac{PxA}{2 \times h \times t} = \frac{54,900}{2 \times 20 \times .062} = 22,200 \text{ psi}$$

$$\tau = \frac{MyA}{A \times t} = \frac{1,310,000}{2 \times 20 \times 10 \times .062} = 53,000 \text{ psi}$$

$$f_b = \frac{MzA \ C}{I_z} = \frac{2,745,000}{204.45} \times 10 = 134,000 \text{ psi}$$

$$f_{max} = \frac{f_b}{2} \pm \tau_{max}$$

$$f_{max} = \frac{134,000}{2} \pm 91,000$$

$$f_{max} = 67,000 \pm 91,000$$

$$f_{max} = 158,000 \text{ psi}$$

$$F_{bu} = 22.5 \text{ ksi}$$

$$MS = \frac{222.5 - 1}{158} = +.40$$

$$\tau_{max} = \sqrt{\left(\frac{f_b}{2}\right)^2 + (\tau_{av})^2}$$

$$\tau_{max} = \sqrt{\left(\frac{13.4 \times 10^4}{2}\right)^2 + (6.18 \times 10^4)^2}$$

$$\tau_{\max} = \sqrt{(45 + 38.3) \times 10^8}$$

$$\tau_{\max} = 91,000 \text{ psi}$$

$$F_{su} = 95,000 \text{ psi}$$

$$MS = \frac{95}{91} - 1$$

$$MS = +.04$$

STRESS ANALYSIS OF BEAM STRUCTURE

Condition #12.C, Table XIV

$$f_{\text{axial}} = \frac{P_y A + P_z A}{A} = \frac{54,900 + 6,700}{4.5 \text{ in.}} = \frac{61,600}{4.5}$$

$$f_{\text{axial}} = +13,700 \text{ psi}$$

$$f_b = \frac{M_{xAC}}{I_x} = \frac{2,715,000 \times 5}{76.21} = 178,000 \text{ psi}$$

$$f_{\max} = 178,000 + 13,700 = 191,700 \text{ psi}$$

$$F_{bu} = 222.5 \text{ ksi}$$

$$MS = \frac{222.5 - 1}{191.7} = +.16$$

Condition #12.d, Table XIV

$$f_{\text{axial}} = \frac{P_y A + P_z A}{A} = \frac{14,200 + 46,200}{4.5} = \frac{60,400}{4.5}$$

$$f_{\text{axial}} = 13,400 \text{ psi}$$

$$f_b = \frac{M_{xAC}}{I_x} = \frac{2,850,000 \times 5}{76.21} = 186,000 \text{ psi}$$

$$f_{\max} = 186,000 + 13,400 = 199,400 \text{ psi}$$

$$MS = \frac{222.5 - 1}{199.4} = +.12$$

Forward and Aft Retractable Beam Strength, Left Side

Material

4340 HT Steel

$F_{tu} = 150$ ksi

$F_{ty} = 132$ ksi

$F_{tu} = 145$ ksi

$F_{su} = 95$ ksi

$E = 29 \times 10^6$ psi

Beam Dimensions and Properties

Aft Beam - WF Shape

$B = 8.962$ in.

$A = 20.86$ in.

$t_f = .79$ in. flange

$t_w = .499$ in. web

Area = 24.10 in.²

$I_{zz} = 1752.4$ in.⁴

$Z_{zz} = 168$ in.³

$e_{zz} = 8.35$ in.

$I_{xx} = 89.6$ in.⁴

$Z_{xx} = 20$ in.³

$e_{xx} = 1.93$ in.

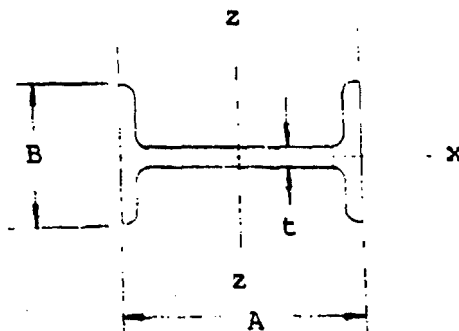

Forward Beam - American Standard

$B = 5.477$ in.

$A = 12.00$ in.

$t_f = .659$ in.

$t_w = .687$ in.

$$\text{Area} = 14.57 \text{ in.}^2$$

$$I_{zz} = 301.6 \text{ in.}^4$$

$$Z_{zz} = 50.3 \text{ in.}^3$$

$$S_{zz} = 4.55 \text{ in.}$$

$$I_{xx} = 16.0 \text{ in.}^4$$

$$Z_{xx} = 5.8 \text{ in.}^3$$

$$S_{xx} = 1.05 \text{ in.}$$

Ultimate Design Condition #8, Table XIV

Aft Beam Analysis

$$\bar{P}_x = 1.5 \times 36,500 \times .6 = 33,000 \text{ lb}$$

Ultimate Allowable Bending Stress (F_{bu})

$$K = \frac{2Q_m}{I/c} = \frac{2Q_m}{Z_{zz}}$$

$$Q_m = \bar{x} \text{ area}$$

$$\bar{x} = \frac{\sum xa}{A} = \frac{.499 \times 9.63 \times 4.8 + .795 \times 8.9 \times 10}{12.05}$$

$$\bar{x} = \frac{22.7 + 60.8}{12.05} = 7.75 \text{ in.}$$

$$K = \frac{2 \times 7.75 \times 24.10}{2 \times 168} = 1.11$$

$$F_{bu} = 166 \text{ ksi} \quad \text{From SDM Figure 4.2.1-8 (Reference 20)}$$

$$F_{by} = 138 \text{ ksi}$$

$$f_{bx} = \frac{M}{I/c} = \frac{\bar{P}_x d}{Z_{zz}} = \frac{33,000 \times 50}{168} = 9,800 \text{ psi}$$

$$MS = \frac{F_{bu} - 1}{f_b} = \frac{166,000 - 1}{9,800} = +16.0$$

$$MS = +16.0$$

Aft Beam Analysis (Cont.)

Ult. Design Condition #15, Table XIV

$$\bar{P}_z = .5 \times 8 \times 3570 = 14300 \text{ Lbs.}$$

$$f_{bz} = \frac{M}{Z_{xx}} = \frac{14300 \times 50}{20} = 36000 \text{ Psi}$$

$$\text{M.S.} = \frac{F_{bu}}{f_{bz}} - 1 = \frac{166000}{36000} - 1$$

M.S. =

Fwd Beam Analysis

Ult. Design Condition #8, Table XIV

$$\bar{P}_x = 1.5 \times 36500 \times .4 = 22000 \text{ Lbs.}$$

$$f_{bx} = \frac{M}{Z_{zz}} = \frac{22000 \times 50}{50} = 22000 \text{ Psi}$$

$$\text{M.S.} = \frac{166}{22} - 1 =$$

M.S. = +6.55

Ult. Design Condition #15, Table XIV

$$\bar{P}_z = 8 \times 3570 \times .5 = 14300 \text{ Lbs.}$$

$$f_{bz} = \frac{M}{Z_{xx}} = \frac{14300 \times 50}{5.8} = 124000 \text{ Psi}$$

$$\text{M.S.} = \frac{F_{bu}}{f_{bz}} - 1 = \frac{166}{124} - 1$$

M.S. = + .34

LONGITUDINAL SUPPORT BEAM ANALYSIS

Critical design flight condition is #9 of Table XIV.

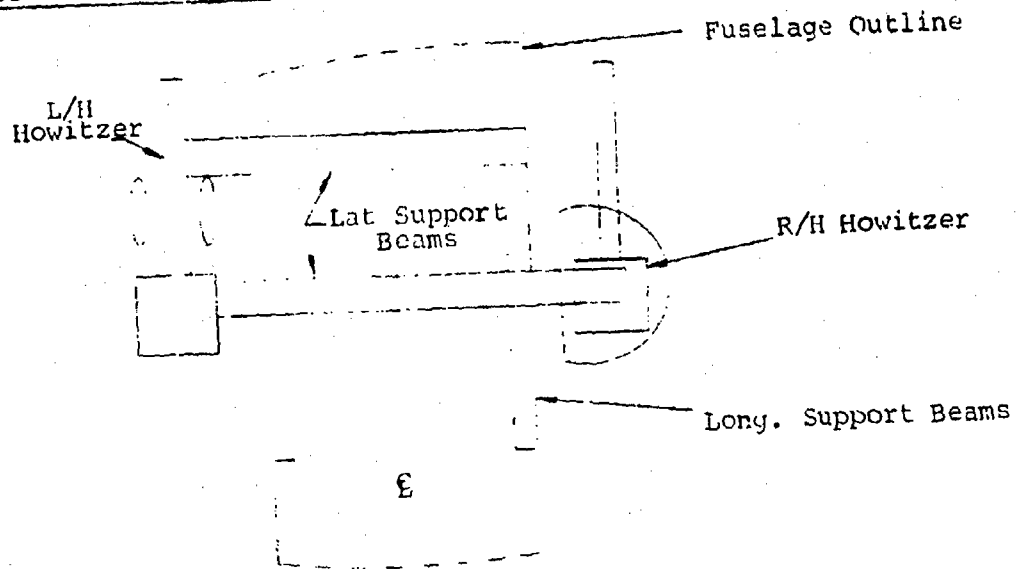
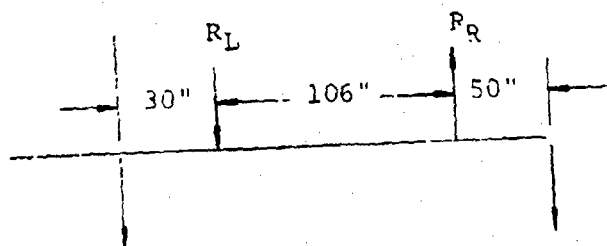
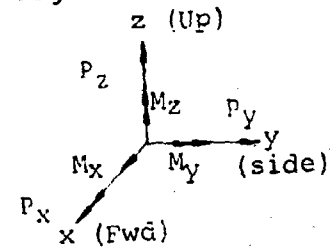

Figure Longitudinal Support Beam

Force Diagram



Sign Convention



$$P_{LU} = 1.5 \times 7000 = 10,500 \text{ lb}$$

$$P_{RU} = 1.5 \times 36,500 = 55,000 \text{ lb}$$

$$eM_{RL} = 0$$

$$50 \times 10500 + 106 \times R_R - 156 \times 55,000 = 0$$

$$R_R = \frac{860 \times 10^4 - 52.5 \times 10^4}{106}$$

$$R_R = 76,000 \text{ lb}$$

$$R_L = 10,500 \text{ lb}$$

Fifty percent of the maximum and (R_R) goes forward in tension and 50 percent goes aft in compression. The compression section will be critical in crippling.

Material Properties

7075-T6 Aluminum Alloy (CLAD)

$F_{tu} = 76 \text{ ksi}$

$F_{ty} = 64 \text{ ksi}$

$F_{su} = 43 \text{ ksi}$

$E = 10.3 \times 10^6 \text{ psi}$

Use Channel Section

Assume

$F_{cs} = .5 F_{cy}$

$F_{cs} = .5 \times 76,000 \text{ lb}$

$P_{cs} = F_{cs} A$

$A = \frac{.5 \times 76,000}{.5 \times 64,000}$

$A = 1.19 \text{ in.}^2$

From Chap C7.4 in Bruhn Figure C7.7

$\left(\frac{F_{cy}}{E_c}\right)^{1/2} = \left(\frac{64,000}{10.3 \times 10^6}\right)^{1/2} = .0788 \quad g = 5 \text{ for a channel}$

$\frac{A}{gt^2} \left(\frac{F_{cy}}{E_c}\right)^{1/2} = .0788 \quad \frac{A}{gt^2} = \frac{.0788 \times 1.19}{5 \times t^2} = 1.15 \text{ (solve for } t)$

$t = \sqrt{\frac{.0788 \times 1.19}{5 \times 1.15}}$

$t = .128$

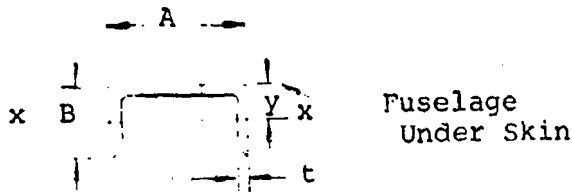

From SDM selected channel size based on

$$A = 1.19 \text{ in.}^2 \text{ and } t = .128 \text{ in.}$$

Channel AND 10137 - 2013

$$A = 2.0 \text{ in.}$$

$$A = 2.5 \text{ in.}$$

$$t = .188 \text{ in.}$$

$$\text{Area} = 1.25 \text{ in.}^2$$

$$y = .939 \text{ in.}$$

$$I_{xx} = .772 \text{ in.}^4$$

$$I_{yy} = .8394 \text{ in.}^4$$

LEFT SIDE HOWITZER TANDEM HOIST LOADS

The two hoists will be sized, based on Appendix II, Design Criteria.

Load factor = 3 g's vertical

Maximum coning angle = 15" in any direction about the vert.

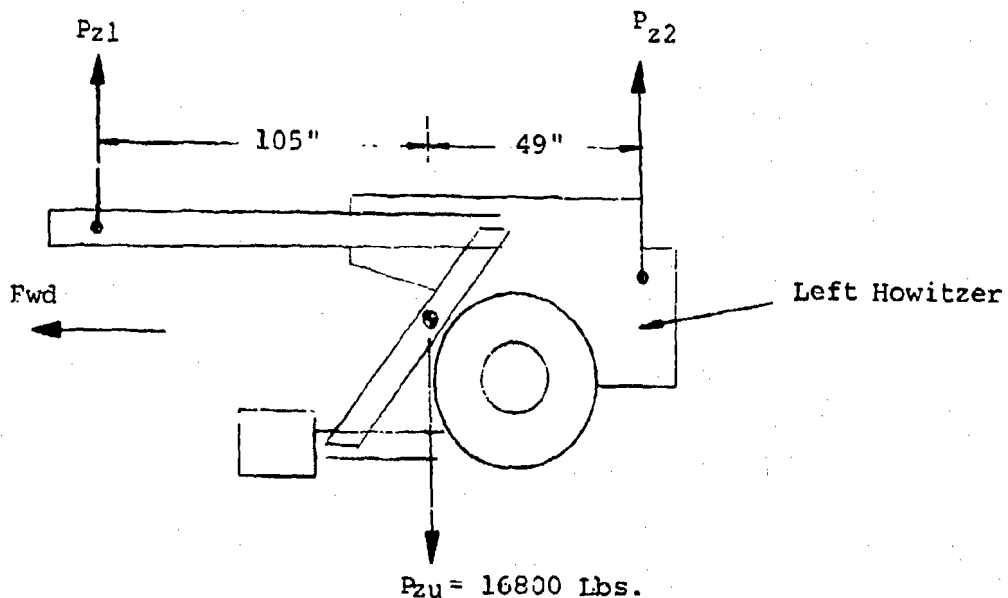

P_{z1} = forward hoist cable reaction load, lb

P_{z2} = aft hoist cable reaction load, lb

Howitzer weight = 3,750 lb

P_{zu} (ultimate design load) = $1.5 \times 3 \times 3,750$ lb

P_{zu} = 16,800 lb

Hoist Cable Ultimate Reaction Loads

Sign Convention - Positive Shown

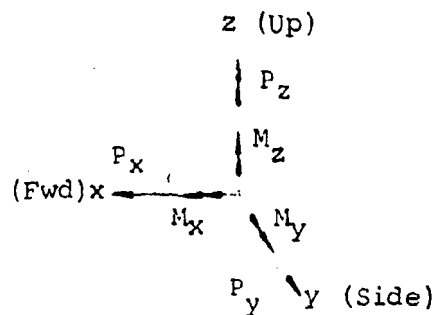

$$\sum F_z = 0$$

$$P_{z1} + P_{z2} = 16,800 \text{ lb}$$

$$\sum M_{cg} = 0$$

$$49 P_{z2} - 105 P_{z1} = 0$$

$$P_{z2} = \frac{105}{49} P_{z1}$$

$$P_{z2} = 2.15 P_{z1}$$

$$\frac{1}{2.15} P_{z2} + P_{z2} = 16,800$$

$$P_{z2} = \frac{16,800}{1.465}$$

$$P_{z2} = 11,500 \text{ lb}$$

$$P_{z1} = 5,300 \text{ lb}$$

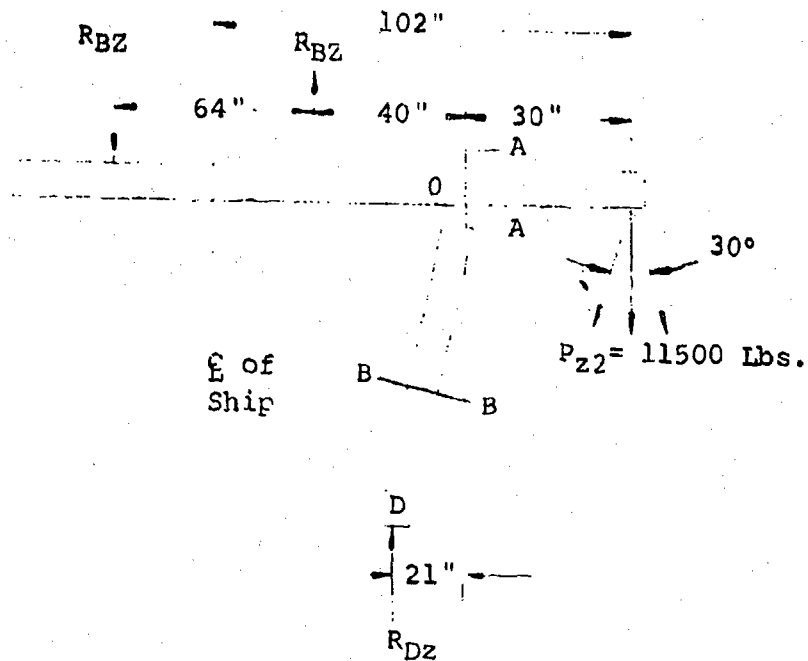

$$\sum F_z = 0$$

$$R_{DZ} = 11,500 \text{ lb}$$

$$\sum M_{Ox} = 0$$

$$- 30 \times 11500 - 21 \times 11500 - 40 R_{BZ} + 104 R_{BZ} = 0$$

$$64 R_{BZ} = \frac{51 \times 11500}{64}$$

$$R_{BZ} = 9,200 \text{ lb}$$

Check

$$\sum M_{2x} = 0$$

$$- 51 \times 11500 - 70 \times 9200 + 134 \times 9200 = 0$$

$$- 51 \times 11500 + 64 \times 9200 = 0$$

$$0 = 0 \quad \therefore \text{OK}$$

Section A-A Required Section (Previous Page)

Hoist Structure Material

7075-T6 Al. Alloy (CLAD)

Properties

$$F_{tu} = 73 \text{ Ksi}$$

$$F_{ty} = 63 \text{ Ksi}$$

$$F_{su} = 44 \text{ Ksi}$$

$$E = 10.5 \times 10^6 \text{ Psi}$$

$$\left. \begin{array}{l} F_{bu} = 115 \text{ Ksi} \\ F_{by} = 84 \text{ Ksi} \end{array} \right\} \text{ for } K = 1.5$$

Plastic Bending at Section A-A About the X Axis

$$F_{bu} = \frac{M}{I/C} = \frac{yPz}{Z_R} = \frac{30 \times 11500}{Z_R} = 115000 \text{ psi}$$

$$Z_R = \frac{30 \times 11500}{115000}$$

$$Z_R = 3.0 \text{ in.}^3 \quad \text{Required}$$

Assumed Section

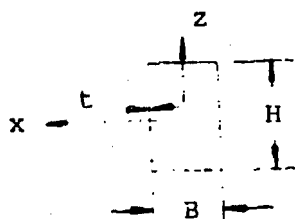

$$H = 6''$$

$$B = 6''$$

$$t = .064''$$

$$I_x = \frac{BH^3 - bh^3}{12}$$

where

$$h = 5.872 \text{ in.}$$

$$b = 5.872 \text{ in.}$$

$$H = 6 \text{ in.}$$

$$B = 6 \text{ in.}$$

$$I_x = \frac{6 \times 6^3 - 5.872 \times 5.872^3}{12} = 9.0 \text{ in.}^4$$

$$z_x = \frac{I_x}{c} = \frac{9.0}{3.0} = 3.0 \text{ in.}^3$$

Area

$$A = 36 - 5872^3$$

$$A = 1.5 \text{ in.}^2$$

$$MS = \frac{z_R}{z_x} - 1$$

$$MS = 0.0$$

Vertical Support Member, Section B-B

Column Instability

$$\text{Allowable Stress } F_c = \frac{\tau^2 E}{(L'/r)^2}$$

Column End Fixity Coefficient

$$C = 4$$

Assume Section same as Section A-A

$$L' = L = 90 \text{ in.}$$

$$r = \sqrt{\frac{I}{A}} = \sqrt{\frac{9.0}{1.5}}$$

$$r = 2.45 \text{ in.}$$

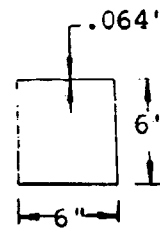

$$L'/a = \frac{90}{2.45} = 37$$

From SDM Figure 4.1.2.1-6 (Reference 15)

$$F_c = 52.5 \text{ ksi}$$

$$f_c = \frac{RDZ}{A} = \frac{11500}{1.5} = 7,670 \text{ psi}$$

$$MS = \frac{F_c - 1}{f_c} = \frac{52500 - 1}{7670}$$

$$MS = +5.85$$

FUSELAGE SKIN DOUBLER SIZE DUE TO GUN BLAST PRESSURE WAVE

The purpose of this analysis is to determine the forward fuselage skin doubler sizes required due to a gun blast at zone 8 charge.

The zone 8 charge is based on an inflight malfunction as shown in Table XII. The aft fuselage will be protected during ground firing by limiting the azimuth travel. Present CH-47C forward fuselage skin thicknesses are shown on the following page.

Material

2024-T3 Aluminum Alloy (CLAD)

δ	- thickness (doubler)	= determine
ρ	- density	= 5.23 slugs/ft ³
C	- speed of sound, f/s	= 16,470
V_c	- critical velocity, f/s	= 240
E	- elastic modulus, psi	= 11×10^6 (1.58 $\times 10^6$ psf)
F_{TU}	- static ultimate strength, psi	= 59,000
F_{TY}	- static yield strength, psi	= 39,000
σ_{yc}	- dynamic yield strength, at V_c , psi	= 143,600
σ_{yc}	- $\rho V_c^2 = \frac{5.23 \times 16470 \times 240}{144}$	= 143,600 psi

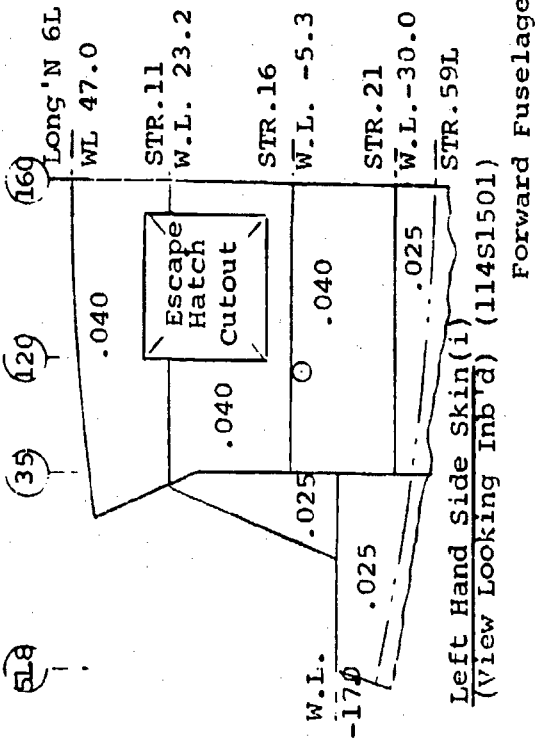
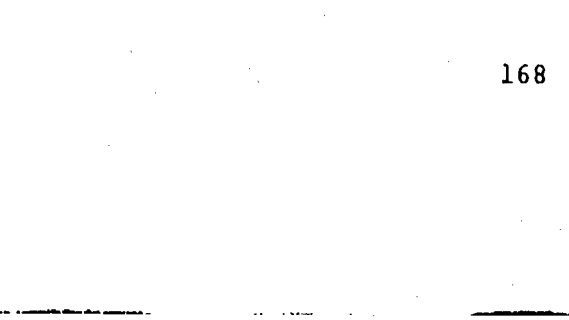
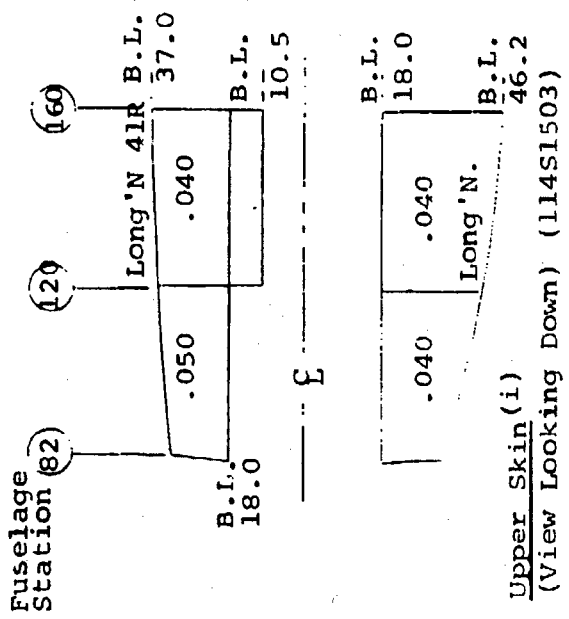
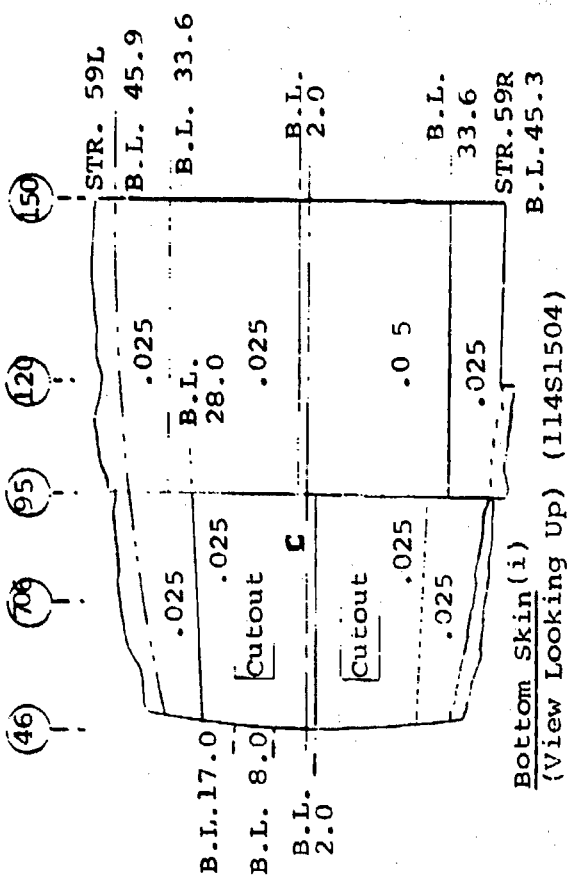

Free-space peak overpressure (p) from a zone 8 howitzer charge is:

$$p = 12.0 \text{ psi}$$

Peak reflected overpressure (p_r) at a surface of interference with the free-space peak overpressure is:

$$p_r = 2p \left(\frac{7p_0 + 4p}{7p_0 + p} \right)$$

where

$$p_0 = \text{ambient pressure} = 14.7 \text{ psi}$$

$$p_r = 2 \times 12 \left(\frac{7 \times 14.7 + 4 \times 12}{7 \times 14.7 + 12} \right)$$

$$p_r = 31.5 \text{ psi}$$

Design pressure (P_D) is equal to peak reflected overpressure (p_r) and the ultimate design pressure $P_u = 1.5 \times p_r$.

$$P_u = 1.5 \times p_r = 1.5 \times 31.5$$

$$P_u = 47.25 \text{ psi}$$

The critical impulse, which is the maximum allowable impulse, is defined in Reference 9 as:

$$I_c = \frac{b \cdot y}{c}$$

where

b = panel thickness

y = dynamic yield strength

c = velocity of sound in material

The critical time (t_c) is the duration the yield pressure must act to obtain sufficient impulse to yield the structure. The critical structure on the CH-47C is a panel normal to the howitzer pressure blast.

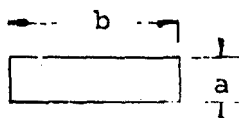

$$a = 5 \text{ in.}$$

$$b = 20 \text{ in.}$$

The panel frequency from the Boeing-Vertol SDM (Reference 20) for simply supported ends is:

$$f = \frac{.985 \times 9.6 \times 10^4}{25}$$

$$f = 3775 \text{ cps}$$

From Reference 9, the critical time t_c is:

$$t_c = \frac{1}{4 \times f} = \frac{1}{4 \times 3775}$$

Equating the impulse required to yield the panel and the critical impulse gives:

$$I_c = I_y = \frac{P_y}{C} = P_y t_c$$

Now P_y is the reflected peak yield overpressure of the panel. Yielding of the panel is considered a failure. 1.5 times the maximum anticipated reflected peak overpressure (p_r) must be $\leq P_y$ to maintain a positive margin of safety.

$$P_y - P_u = 1.5 \times p_r = 1.5 \times 31.5 = 47.25 \text{ psi}$$

$$\delta = \frac{P_y t_c C}{c y} = \frac{P_y C}{4 \times 3775 \text{ cps} \times c y}$$

$$\delta^2 = \frac{P_y C}{4 \times 3775 \text{ cps} \times c y} = \frac{47.25 \times 16470 \times 12}{4 \times 3775 \times 143,600}$$

$$\delta^2 = .0043$$

$$\delta = .065 \text{ in.}$$

A doubler thickness of .065 in. is required to withstand a zone 8 howitzer blast.

GROUND FIRING AZIMUTH ANGLE REQUIRED TO PREVENT BLAST DAMAGE TO AFT FUSELAGE

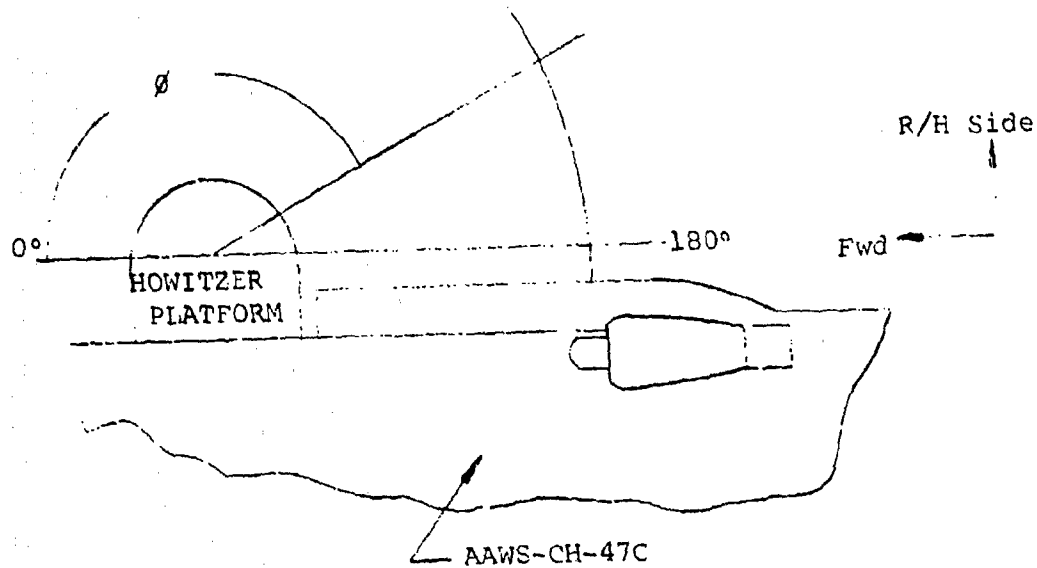

Skin - 2024-T3 Al. Alloy (CLAD)

t_c = Skin Thickness = .025 In.

Max. Overpressure aft fuselage can support

$$I_c = \frac{3 \rho_{yc}}{c} \quad I_A = 1.5 P_D \times t_c$$

$$P_D = \frac{3 \rho_{yc}}{1.5 c t_c} = \frac{.025 \times 143600}{1.5 \times 16470 \times .003 \times 12}$$

$P_D = 4.04$ Psi (Max. Allowable free-space overpressure for present skin)

Required gun azimuth position to prevent an overpress. of the aft starb'd fuselage skin is: = 150°

ESCAPE HATCH WINDOW PLEXIGLAS DOUBLER ANALYSIS

Drawing No. 114S-2721

Material Properties from Lockheed Stress Memo No. 124.

Plexiglas II Solid

$$E = 4.5 \times 10^5 \text{ psi}$$

$$F_{tu} = 10.3 \text{ ksi}$$

$$F_{cu} = 17.0 \text{ ksi}$$

$$F_{bu} = 16 \text{ ksi}$$

$$F_{su} = 9.0 \text{ ksi}$$

$$\nu = .35 \text{ (Poisson's ratio)}$$

$$\gamma = .015 \text{ lb/in.}^3$$

The ultimate allowable design stress extension is

$$F_{uA} = 2/3 \times 10300 = 6,900 \text{ psi}$$

Pilot escape hatch door strength as determined from tests at Boeing-Vertol, Drawing No. 114S-1713. Pane was loaded without failure to 1.2 psi,

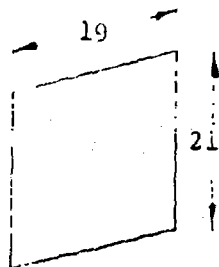

$$t = .187 \text{ in.}$$

From Roark, Pg. 246 (Reference 21)

$$\text{Coef.} = k = \frac{p b^3}{Et^4} = \frac{1.2 \times 19^3}{4.5 \times 10^5 \times .187^4}$$

$$k = 284$$

$$\frac{S_{ub}}{Et} = 72.5$$

$$S_a = 72.5 \frac{Et}{b^3} = \frac{72.5 \times 4.5 \times 10^5 \times .187^3}{19^3}$$

$$S_a = 3,160 \text{ psi (test substantiated under static loading)}$$

Dynamic Stress Analysis of Circular Fuselage Escape Hatch
Doubler

Applied peak reflected overpressure based on a zone 8 charge,

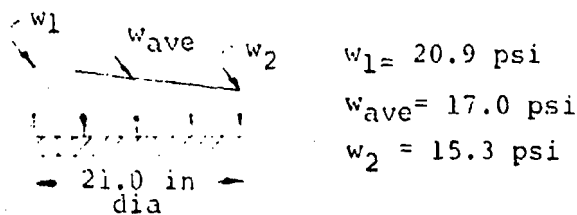

$$w_1 = 20.9 \text{ psi}$$

$$w_{\text{ave}} = 17.0 \text{ psi}$$

$$w_2 = 15.3 \text{ psi}$$

$$P_L = 17 \text{ psi (limit)}$$

$$P_U = 1.5 \times 17 = 25.5 \text{ psi (ultimate)}$$

$$F_{U(\text{all})} = 6,900 \text{ psi}$$

Assume a dynamic coefficient of 2.0 for plastics.

Required doubler thickness without a stiffener using design allowable of $F_{U(\text{all})} = 6,900 \text{ psi}$

Stress formula from Roark, Pg. 216, case no. 6 (Reference 21),

$$S_r(\text{max}) = \frac{3W}{4rt} \quad W = P_U r^2$$

$$S_r = F_{U(\text{all})} = 6,900 \text{ psi (} F_{U(\text{all})} \text{ dynamic} = 2 \times 6900)$$

$$P_U = 25.5 \text{ psi}$$

$$r = 10.5 \text{ in.}$$

$$t = \sqrt{\frac{3 \times P_U \times r^2}{4 \times F_{U(\text{all})} \text{ dyn.}}} = \sqrt{\frac{3 \times 25.5 \times 10.5^2}{4 \times 2 \times 6900}}$$

$$t = .39 \text{ in.}$$

Required doubler thickness without a stiffener using test allowable of $S_a = 3,160 \text{ psi}$.

$$t = \sqrt{\frac{3 \times 25.5 \times 10.5^2}{4 \times 2 \times 3160}}$$

$$t = .58 \text{ in.}$$

Pilot Escape Door Doubler Analysis

Applied peak reflected overpressure at panel is

$$P_L = 5.8 \times 2 = 11.6 \text{ psi}$$

Ultimate

$$P_u = 1.5 \times 11.6 = 17.4 \text{ psi}$$

Allowable stress $F_u(\text{all}) = 6,900 \text{ psi}$

Allowable dynamic stress = $2 \times 6,900 \text{ psi}$

Required doubler thickness

$$t = \sqrt{\frac{2 F_u(\text{all}) b^2}{72.5E}} = \sqrt{\frac{2 \times 6900 \times 19^2}{72.5 \times 4.5 \times 10^6}}$$

$$t = .39 \text{ in.}$$

ROTOR BLADE SPAR STRESSES DUE TO MUZZLE BLAST

The ultimate maneuver stresses were calculated at six critical stations to include the increase in stress caused by muzzle blast. A 1.5 ultimate factor is included in this stress. The maximum stress was 13,000 psi attained at $x/R = 0.187$. This stress level yields a margin of safety (MS) of

$$MS = \frac{\sigma_{cu}}{\sigma} - 1 = \frac{150,000}{135,000} - 1$$

$$MS = +0.11$$

The additional moment per inch at the spar-to-box attachment due to a uniform pressure of 1.2 psi applied to the box is

$$\begin{aligned} \Delta M &= 1/2 (\text{chord} - \text{spar})^2 \Delta P_{\text{blast}} (1.5) \\ &= 1/2 (25.25 - 7.1)^2 (1.2) (1.5) \\ &= 300 \text{ in-lb/in.} \end{aligned}$$

The allowable ultimate compression stress is $\sigma_{cu} = 38,200$ psi (Reference 22). At $x/R = .95$, the maximum maneuver flight air pressure loading is a maximum and causes a compression stress of $\sigma = 26,470$ psi. The stress due to the blast is

$$\sigma_{\text{blast}} = \frac{\Delta M}{d \times t \times l}$$

where

d = distance between top and bottom skins

t = skin thickness

$$\sigma_{\text{blast}} = \frac{300}{(2.52)(.018)} = 6540 \text{ psi}$$

The margin of safety is therefore reduced from $MS = +.44$ to:

$$\begin{aligned} MS &= \frac{\sigma_{cu}}{\sigma} - 1 \\ &= \frac{38,200}{(26,470 + 6540)} - 1 \end{aligned}$$

$$MS = +0.16$$

A blast pressure which would cause a MS = 0 would be:

$$P_{\text{blast}} = \frac{2 M d t}{(\text{chord} - 7.1)} = \frac{2(38,200 - 26,470)(2.52)(.018)}{(25.25 - 7.1)^2 1.5}$$
$$= 3.23/1.5$$

$$P_{\text{blast}} = 2.09 \text{ psi}$$

While this small pressure implies a small margin, the above calculation is based on firing during a maximum maneuver condition and is therefore extremely conservative.

The spar stress fatigue limits (M - 3) have been calculated by adding the stresses due to firing to the maximum level flight stresses at the critical blade stations. These calculations show that the increases in the stress levels at these critical blade stations due to the pressure blast do not create any fatigue problems at the stations indicated. Calculations of the effects of the muzzle blast on the fatigue strength of the blade aerodynamic fairing have also been performed for the critical blade section. The additional alternating moment per inch due to the blast pressure at $x/R = .95$ is

$$M = 100 \text{ in-lb/in.}$$

The maximum level flight alternating moment is 108 in-lb/in. (Reference 19), and the fatigue endurance limit is 243.6 in-lb/in. The fatigue limit is therefore not exceeded, and the margin of safety is:

$$MS = \frac{243.6}{208} - 1$$

$$MS = +0.17$$

APPENDIX V

DETAIL WEIGHT SUBSTANTIATION

	<u>Weight</u>
	<u>lb</u>
1. Crash Resistant Fuel System (Ref. ECP 626)	586
2. Beam Attachment Forgings (Aluminum)	25
Forward (4 req'd) 20 cu in. @ 0.1 lb/cu in.	8
Aft (4 req'd) 30 cu in. @ 0.1 lb/cu in.	12
Attaching Hardware	5
3. Frame Reinforcements (5 req'd) (aluminum)	(12) (5) 60
1,820 sq in. x 0.06 in. thick @ 0.1 lb/cu in.	11
Rivets, etc.	1
4. Muzzle Blast Doublers (2 req'd)	(55) (2) 110
Add aluminum plates	
5,201 sq in. x 0.065 in. thick @	34
0.1 lb/cu in.	
Upper Sliding Side Window, Double	4
Thickness of Glass 1.93 lb x 2	
Lower Fixed Side Window, Double Thickness	8
of Glass 3.86 lb x 2	
Escape Hatch Window, Double Thickness	3
of Glass 1.4 lb x 2	
Attaching Hardware Including Rubber Snubbers	6
5. Forward Hoist	96
Lateral Beam (Aluminum)	22.5
1.5 sq in. x 150 in. long x 0.1 lb/cu in	
Vertical Support (Aluminum)	13.2
1.5 sq in. x 88 in. long x 0.1 lb/cu in.	
Diagonal Brace (Aluminum)	2.2
1.0 OD x 0.08 in. wall x 90 in. long x	
0.1 lb/cu in.	
Gusset - Main Boom (Aluminum) (2 req'd)	3
170 sq in. x .125 in. thick x 0.10 lb/	
cu in. x 2	
Fitting - Bottom Vertical Est.	1
Fitting - Diagonal Vertical Est.	1
Attaching Hardware	5
Hydraulic Winch, Breeze BL 4600	41
Winch Control Panel, Valve, Pump, Electrical	7
Connectors, etc.	
6. Aft Hoist - Same as Forward	96

		Weight <u>lb</u>
7. Gun Support Platform		155
Lateral Beam (Aluminum) (6 req'd)	12	
60 cu in. x 0.10 lb/cu in. x 6		
Spokes (Aluminum) (5 req'd)	22	
44 cu in. x 0.1 lb/cu in. x 5		
Ring Gear (Steel)	42	
141 cu in. x 0.3 lb/cu in.		
Walking Platform Screen	41	
8,221 sq in. x 0.005 lb/sq in.		
Attaching Hardware	13	
Screw Jack Est.	25	
8. Forward Lateral Gun Support		586
Lateral Main Beam (Steel)	77	
257 cu in. x 0.3 lb/cu in.		
Lateral Extension Beam (Steel)	469	
1,562 cu in. x 0.3 lb/cu in.		
Bearings, Stops, etc.	15	
Attaching Hardware	25	
9. Aft Lateral Gun Support		1,328
Main Beam (Steel)	265	
883 cu in. x 0.3 lb/cu in.		
Aft Lateral Extension (Steel)	1,023	
3,410 cu in. x 0.3 lb/cu in.		
Bearings, Stops, etc.	15	
Attaching Hardware	25	
10. Longitudinal Beams - Aluminum		48
Forward (2 req'd)	19	
95 cu in. x 0.1 lb/cu in. x 2		
Aft (2 req'd)	19	
95 cu in. x 0.1 lb/cu in. x 2		
Hardware	10	
11. Tie-Down Dogs and Clamps, Est.		25
12. Electric Motors and Controls, Est.		60
13. Gun Fire Controls, Est.		50
14. Ammunition Loaders, Est. (each)		200
15. Ammunition Racks and Cans (Steel)		140
28 in. diameter x 36 in. long @ equivalent thickness = 0.13 in. (each)		
16. Ferry Fuel Tank - from extended range studies:		600
Tank, 600 gal capacity	497	
Plumbing	28	
Pallet, Tie-Downs, etc.	75	

		Weight <u>lb</u>
17.	Rotor Brake - from CH-47C Australian Proposal:	51
	Brake	29
	Motor Pump	20
	Remove Solenoid and Valve	-2
	Miscellaneous	4
18.	Ammunition (each)	37
	Projectile	33
	Charge (zone 5)	1.4
	Case	2.6
19.	Howitzer - Left Side	3,751
	Ref.: Preliminary draft, technical manual, operations and organizational maintenance manual, howitzer light, towed, 105 soft recoil, XM204, dated March 1970	3,615
	Add 30 in. to barrel, Est.	136
20.	Howitzer - Right Side	3,200
	Howitzer Left Side (above)	3,751
	Remove: Transverse mechanism	-273
	spindle, brakes and wheels	-140
	Sections of baseplate and carriage, Est.	-138

APPENDIX VI

TEST FIRING OF MODEL HOWITZER TO PRODUCE MUZZLE BLAST FIELDS

The feasibility of modeling the XM204 howitzer for the generation of a scaled muzzle blast field was investigated. This effort was to provide for subsequent testing of Boeing's fully-instrumented 1/11-scale model of the Chinook CH-47C helicopter in a model blast environment. Determination of the effects of muzzle blast on rotor and airframe loads by firing a model weapon in the proximity of the model helicopter would be a valuable step in the progression toward full-scale airborne testing of the helicopter-mounted howitzer. Results summarized in Figure 62 show that modeling is feasible and can produce correlation with full scale within 0.5 psi.

SCALING TECHNIQUES

Fabrication of the 1/11-scale model of the XM204 105mm howitzer was accomplished by use of Hopkinson scaling techniques. These replica model laws, discussed in Reference 23, are presented in Table XX. In brief, all linear dimensions scale as the geometric length ratio (11:1). Mass, weight, and energy scales as the cube of the geometric length ratio (1331:1), and blast pressure (measured at scaled distances) and projectile velocity of the model have a one-to-one relationship with that of the full-scale weapon.

Table XXI lists the pertinent parameters of XM204 howitzer and the corresponding parameters of the model weapon as determined by application of the replica modeling laws. The scaling laws would dictate the scaling of the propellant on a weight basis with the model rounds loaded with 1/1331 times the weight of propellant in its full-scale equivalent if the model propellant had the same specific energy content as the full-scale propellant. Data obtained from the manufacturer (Hercules) of the model propellant (Unique) showed that its heat of explosion, a measure of energy content, was 1,145 calories per gram as contrasted with 770 calories per gram for the M-1 propellant used in the 105mm rounds. Propellant scaling therefore had to take energy into account; and the values of model propellant, shown in Table XXI, used a scale factor equal to $770/1145 \times 1/1131 = 4.59 \times 10^{-4}$. The model propellant weight equivalent to the 2.82-pound zone 7 charge is therefore:

$$2.82 \times 4.59 \times 10^{-4} \times 7000 = 9 \text{ grains}$$

Model Weapon

Application of the 1/11-scale factor to the 105mm howitzer

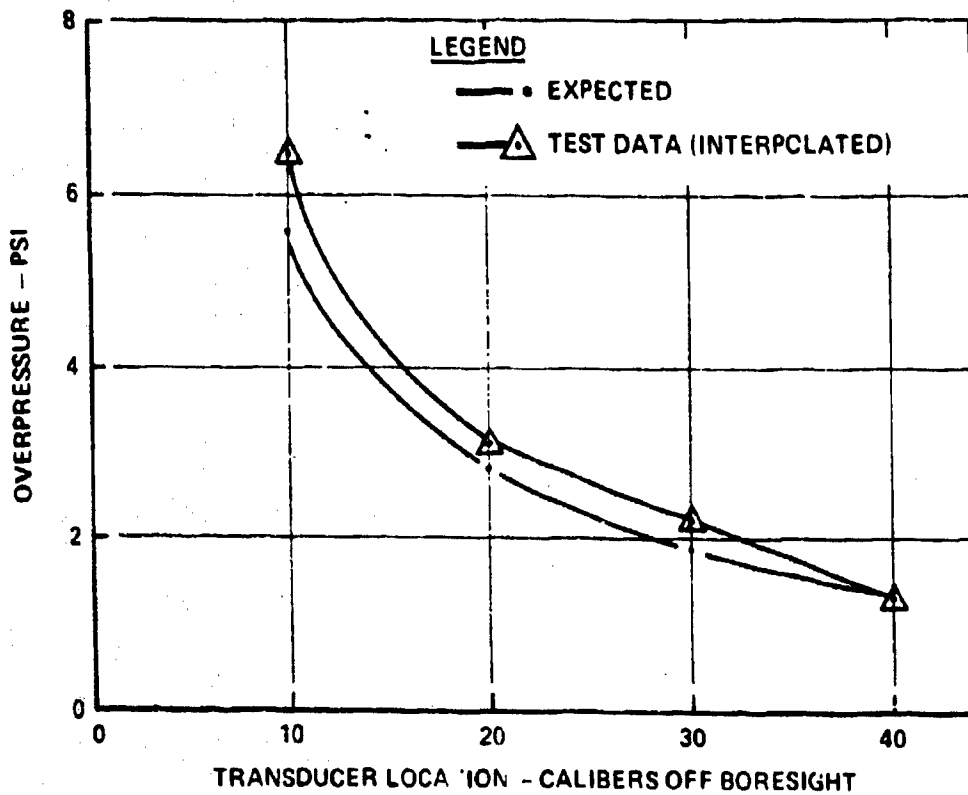

Figure 62. Comparison of Predicted and Model Overpressure Measurements for 2.82 Pounds (Zone 7) of Equivalent Full-Scale Charge

TABLE XX. REPLICA MODEL (HOPKINSON) SCALING LAWS

Parameter	Scale Factor
Barrel Length	λ
Bore	λ
Measurement Distances	λ
Projectile Mass	λ^3
Propellant Weight	λ^3
Blast Pressure (Measured at Scaled Distances)	1.0
Projectile Velocity	1.0

λ = Geometric Length Ratio

TABLE XXI. MODEL VERSUS FULL-SCALE WEAPON PARAMETERS

Parameter	XM204	Model
Barrel Length	150 in.	13.60 in.
Bore	105mm	.375 in.
Projectile Weight	33 lb	173 grains
Propellant Weight	(scaled on an energy basis)	
<u>Charge Zone</u>		
7	2.82 lb	9.03 grains
6	1.91 lb	6.15 grains
5	1.38 lb	4.42 grains
4	1.01 lb	3.23 grains

resulted in a model weapon bore of .375 caliber which is a standard available barrel. A 1917 model Eddystone barrel was obtained and cut to 11.75 inches in length. The barrel was then married to a Remington-Essington action and the trigger mechanism modified for lanyard pull operation with appropriate safety devices added. Figure 63a shows the model weapon on the test mount.

Ammunition

Modeling of the ammunition necessitated foreshortening and counterboring the nose of the projectile to attain the required scaled weight of 173 grains. As the program goal was to build a replica model "blast-maker," degradation of projectile velocity caused by this unorthodox nose shaping was of no concern. Similarly, projectile length was not scaled. Figure 63b is a photograph of the model round.

MEASUREMENT TECHNIQUES

Testing included acquisition of blast data and evaluation of various types of transducers. The test setup for measurement of blast overpressures was essentially the same for all transducer types used. As two-channel recording was available, only two transducers could be used at any time. Transducer location was measured in calibers (actual distances divided by the diameter of the weapon's bore). In this manner, comparative measurements at a given number of calibers could be made for model and full-scale weapons.

In all measurements, transducers were located in a plane perpendicular to, and 14.4 calibers forward of, the muzzle and at distances of from 10 to 50 calibers from boresight of the weapon. The selection of 14.4 calibers forward was made to locate the measurements along a radius from the center of the blast.

A sand-filled five-gallon can with a cardboard lid was used as a bullet catcher and was located approximately 10 feet in front of the weapon.

A microphone was positioned nearer to the muzzle than either transducer at a location experimentally determined for each test setup to provide triggering for an oscilloscope. A Polaroid oscilloscope camera was employed for data recording.

Microphone transducers were fed directly into the oscilloscope input, as were the Pitran pressure transducers. The SWRI pancake transducers required the use of charge amplifiers prior to signal application to the oscilloscope. Kulite pressure transducers required use of a wide band amplifier which also provided a buffering function.

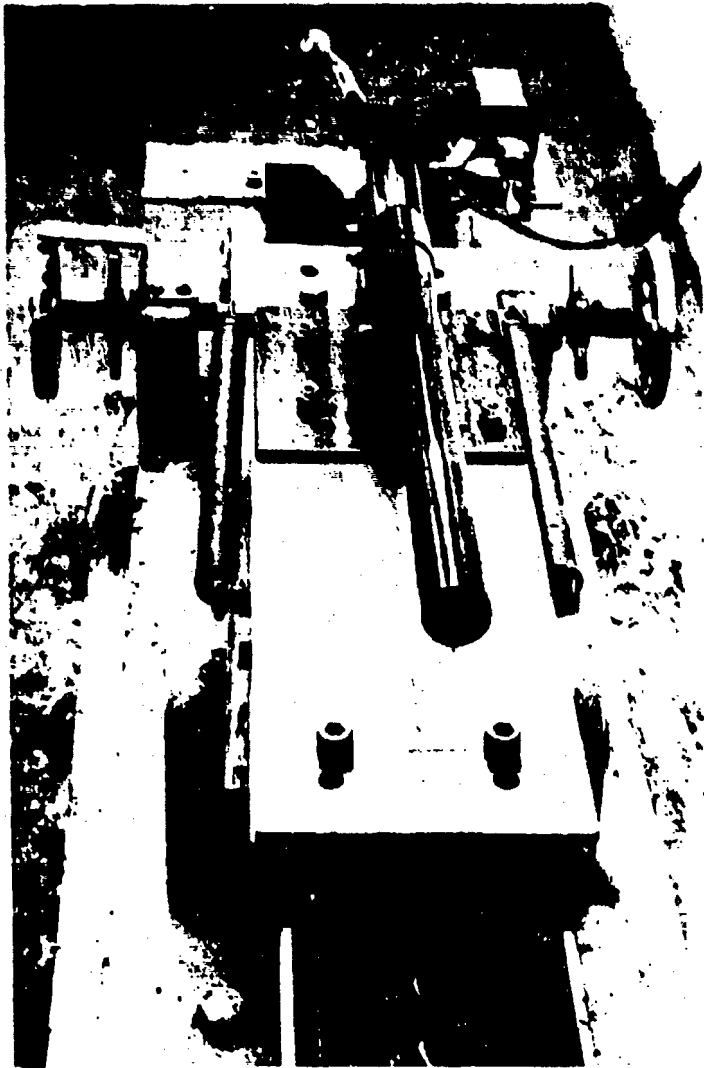

a



b

Figure 63. (a) Scale Model Weapon on Ballistic Test Mount
(b) Model Ammunition Showing Projectile Modifications

Muzzle velocity tests were performed in the Boeing test range (Figure 64) by firing through screens 25 and 35 feet from the muzzle. A clock started as the projectile passed a photocell in the first screen and was stopped by a similar one in the second screen. Velocity was determined by dividing the fixed distance by the measured time. Figure 65 is a plot of velocity test data.

TESTING

First Test Series

The initial test series was conducted on April 24, 1972, with an objective of obtaining model blast pressure data at locations of 20, 30, 40, and 50 calibers off boresight which would correlate well with XM204 data and thus validate the model weapon. Figures 66 to 69 show typical oscilloscope traces.

Of the 11 rounds of assorted charge weight fired, one was a blank to check the test setup, two produced no data due to faulty instrumentation, one produced abnormally high pressures and was discounted, and the remaining five rounds produced meaningful data and good correlation.

Figure 70 shows comparison of predicted and model overpressures measured at 50 calibers using the microphone transducer. Test data fell within .3 psi of predictions. Data taken at 40 calibers using microphone transducers are shown plotted on Figure 71. Scope traces of the runs made at 11 and 14 grains of propellant displayed blunted pressure peaks which were apparently caused by the microphone dynamic response. Data enhancement was effected by extrapolation of the recorded pressure amplitude trace to provide well defined maxima for those two data points. Relocation of these data points produced a better-shaped curve with very good correlation.

Although this initial test series produced encouraging results, its limited number of firings and some then unexplainable results cast doubts on the weapon's repeatability and caused the test conclusions to be suspect. Measurements could not be made at x/c (distance in calibers off boresight) of 20 and 30 as the predicted pressure levels exceeded the microphone transducer limitation, and the Pitran pressure transducers which had this capability had produced the abnormally high overpressures. In addition, the lower charge zone projectiles lodged in the barrel, casting doubts on the validity of the scaling.

Initial Boeing analysis with subsequent confirmation by Southwest Research Institute determined the cause of the abnormal Pitran transducer data to be due to the method of mounting and the orientation of the mounting plate within the blast field. The flat plate mount had been inadvertently positioned so as to disturb the blast field and produce a reflected pressure



Figure 64. Setup For Muzzle Velocity Measurement in Boeing-Vertol Test Range

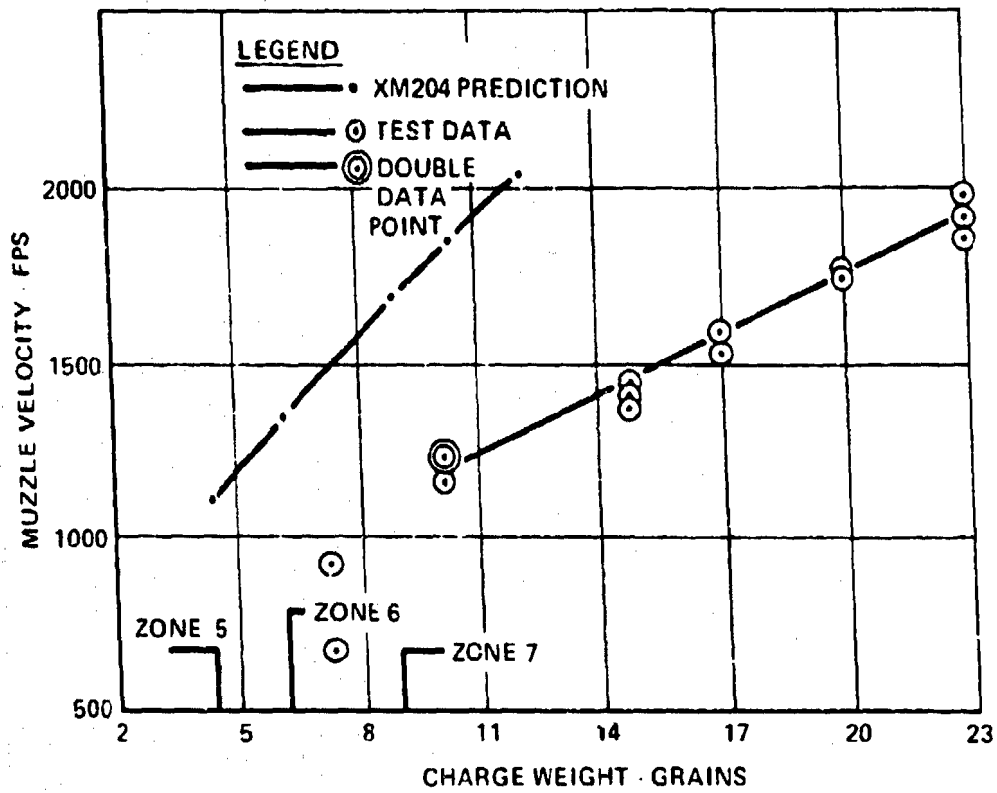

Figure 65. Comparison of Full-Scale and Model Muzzle Velocity Measurement

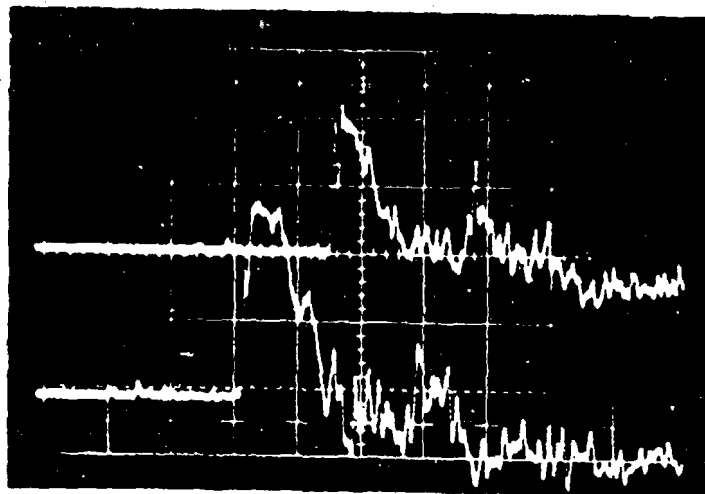

Figure 66. Scope Trace of 14 Grain Firing Test
 Upper - Microphone Transducer at 50 Calibers
 (scale: 0.36 psi/cm; 200 μ sec/cm)
 Lower - Microphone Transducer at 40 Calibers
 (scale: 0.46 psi/cm; 200 μ sec/cm)

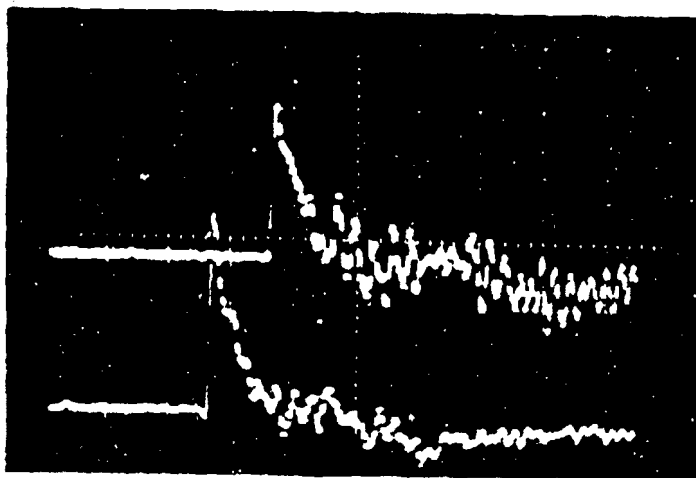

Figure 67. Scope Trace of 10.1 Grain Firing Test
 Upper - SWRI "Pancake" Transducer No. 14-9 at 30
 Calibers (scale: 1.03 psi/cm; 200 μ sec/cm)
 Lower - SWRI "Pancake" Transducer No. 25-2 at 20
 Calibers (scale: 1.18 psi/cm; 200 μ sec/cm)

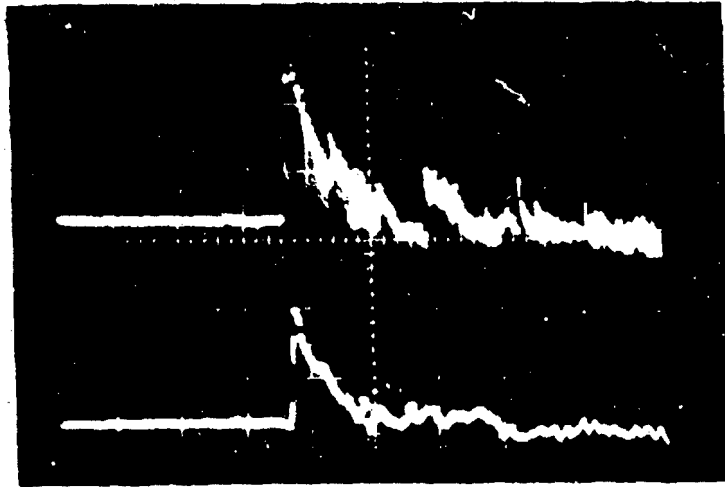
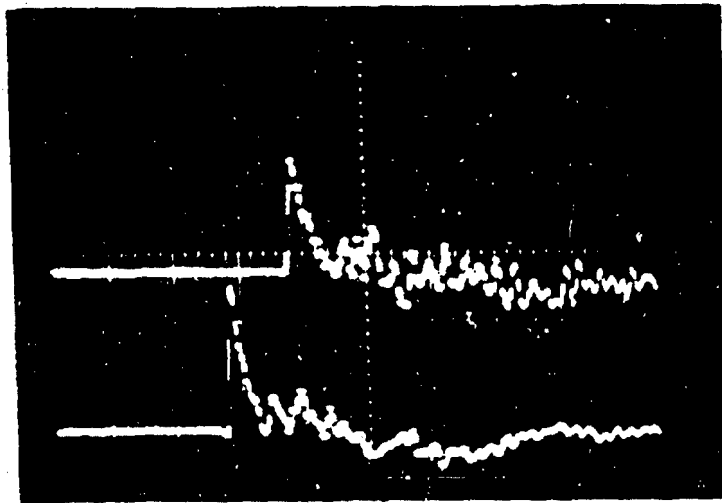

Figure 68. Scope Trace of 17 Grain Firing Test
 Upper - Kulite Transducer at 40 Calibers (scale: 1.91 psi/cm; 200 μ sec/cm)
 Lower - SWRI "Pancake" Transducer No. 25-2 at 40 calibers (scale: 1.18 psi/cm; 200 μ sec/cm)



Reproduced from
 best available copy.

Figure 69. Scope Trace of 7.25 Grain Firing Test
 Upper - SWRI "Pancake" Transducer No. 14-9 at 30 Calibers (scale: 1.03 psi/cm; 200 μ sec/cm)
 Lower - SWRI "Pancake" Transducer No. 25-2 at 20 Calibers (scale: 1.18 psi/cm; 200 μ sec/cm)

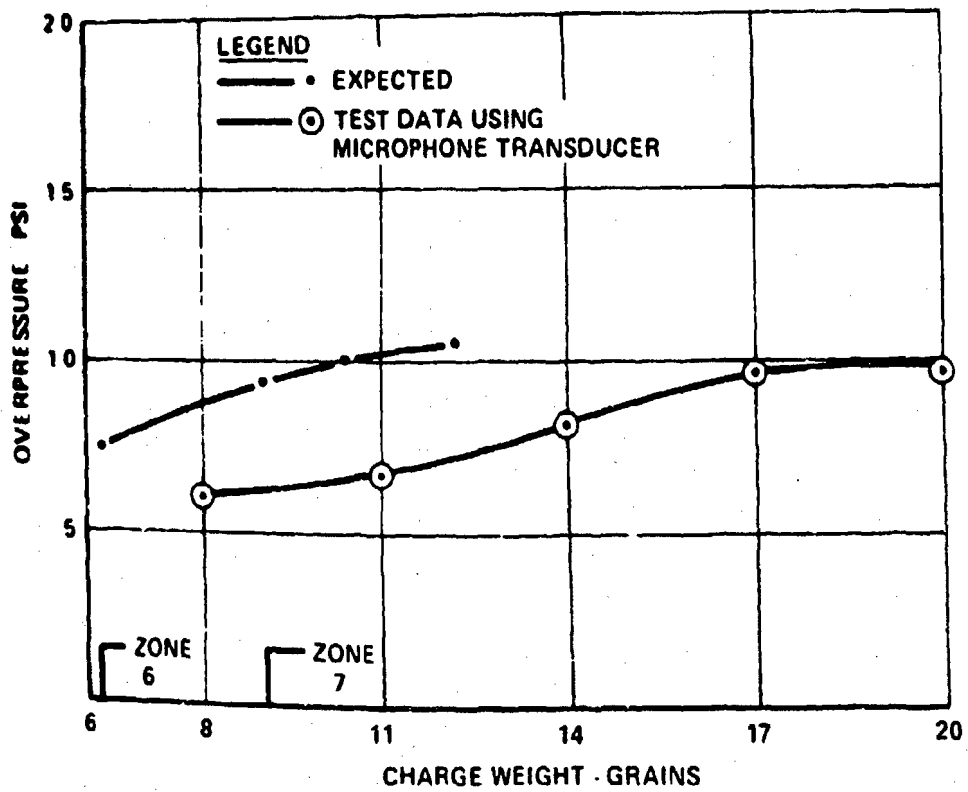

Figure 70. Comparison of Predicted and Model Overpressure Measurements at 50 Calibers Off Boresight

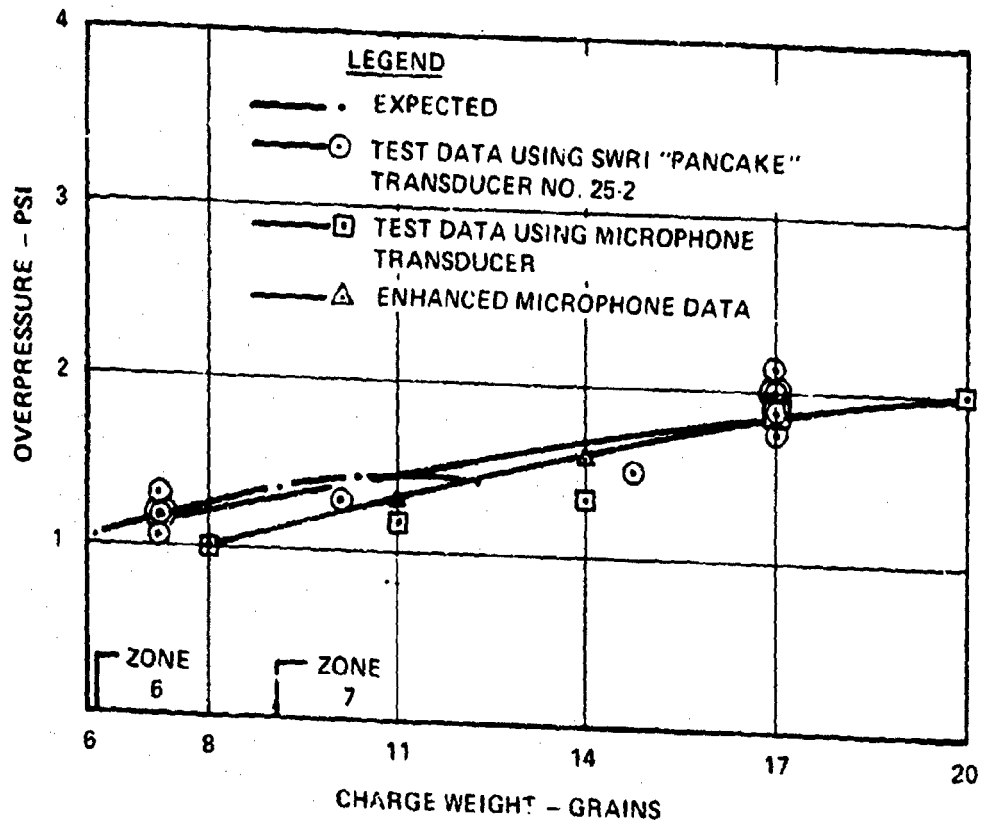

Figure 11. Comparison of Predicted and Model Overpressure Measurements at 40 Calibers Off Boresight

wave. It was later determined that the measured reflected overpressures actually correlated well with calculations based upon the free-space (nonreflective) overpressures produced and the angle of incidence of the wave striking the mount.

With the criticality of transducer aerodynamics and orientation thus established, it was necessary to obtain transducers capable of measuring free-space overpressures without causing wave disturbance. It was learned that Southwest Research Institute had designed and built a limited number of blast gauges for the Naval Weapons Laboratory at Dahlgren, Virginia (Reference 24), which were ideally suited for measurement of the fast rise time pressure pulses produced by small-caliber weapons. Furthermore, its pancake-shaped head, feathered periphery, and sharp edge afforded excellent aerodynamics and caused minimum wave disturbance. The Naval Weapons Laboratory (Dahlgren) readily agreed to provide four of these pancake units, but they cautioned that their experience with the gauges had not been satisfactory due to a problem with noise. Dahlgren advised that Kulite transducers had produced excellent results for them and suggested this type of gauge be used. Two of the Kulite gauges were purchased and installed in mounts patterned after the SWRI gauges. It was planned to compare performance of the Kulite and SWRI gauges in the second series of test firings.

Repeatability would be verified in the second test series by multiple firings for given charge weights at specific transducer locations, as contrasted with the single firing for each condition performed in the initial tests.

The problem of projectiles lodging in the barrel was analyzed, and its suspected cause was the failure to scale the engraving surface of the projectile. The length of the engraving surface of the model projectile was considerably greater than that dictated by application of the scale factor to the full-scale projectile. The resulting increase in engraving, it was theorized, resulted in the model projectile lodging in the barrel for low charge zones. It was planned that the second test series would employ some projectiles with reduced engraving for low zone firings. Figure 72 shows comparison of the standard and reduced engraving of the model projectile.

Second Test Series

The second series of test firings was performed on June 29. Fifty rounds were fired in the effort to validate the weapon as a true blast maker capable of producing overpressures at 1/11 scale that of the XM204. Of the 50 rounds fired, four were blanks to assist in test setup, five rounds produced no data due to loss of the electronic trigger signal for the oscilloscope, and one round (without reduced engraving)

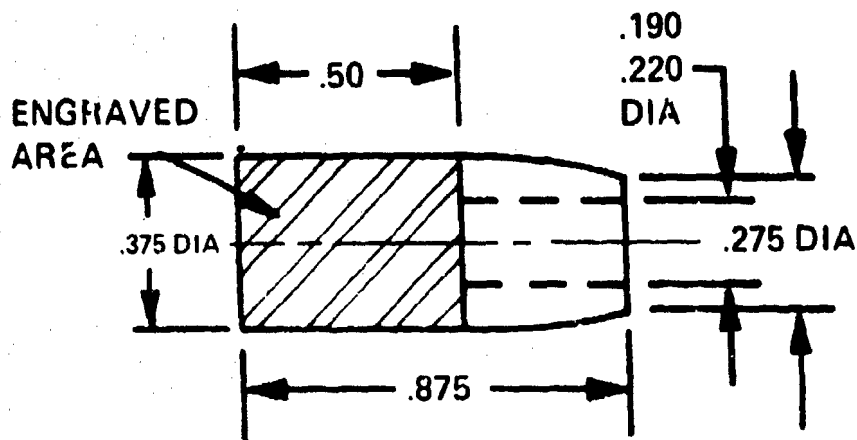

(a) STANDARD ENGRAVING

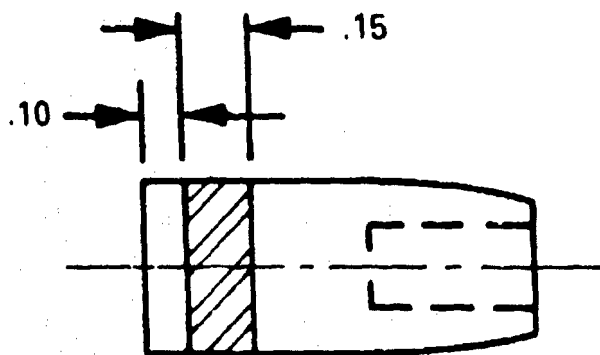

(b) REDUCED ENGRAVING AREA

Figure 72. Geometry of Model Projectile

lodged in the barrel. The remaining 38 rounds, with the exception of several odd data points, produced repeatable data which showed good correlation with predicted levels of overpressure.

The first number of runs was designed to compare the SWRI pancake transducers with the Kulite transducers. One of each type was located at $x/c = 40$. Figure 73a is a photograph of the test setup.

Transducers were oriented with their knife edge in the horizontal plane to enable the incident pressure wave to roll across them with minimal disturbance. This arrangement, suggested by William Burgess of Dahlgren, is superior to positioning in the vertical plane since aiming of the knife edge at the center of the blast is less critical. A microphone transducer used to provide a trigger for the oscilloscope can also be seen in the photograph.

During the course of data reduction and analysis of this second test series, it became increasingly apparent that the SWRI gauges were out of calibration. Attempts to calibrate them with regular calibration equipment, as well as attempts to build a simple calibrator, proved fruitless due to the rapid rise times necessary for the calibrating shock pulse. Once again, Dahlgren cooperated by providing the special calibrator which SWRI had built for these pancake transducers. Figure 74 is a photograph of the calibration test setup used. Shown are transducers, calibrator, charge amplifiers, oscilloscope and ancillary equipment. After successful calibration of the transducers, data taken with two SWRI transducers correlated with each other and reduction and analysis were continued.

Figure 71 is a plot of the overpressures measured at 40 calibers by SWRI pancake gauge 25-2 for 11 rounds fired at 7.25, 10.1, 14.8, and 17 grains of propellant weight. Repeatability proved to be quite good, and results correlate well with the predicted curve.

The results of the Kulite transducer measurements proved to be somewhat disappointing due to the presence of hash or ringing in the resulting scope traces (see Figure 68). As it could not be determined where in these traces to read the true overpressure levels, both the maxima and minima of all Kulite measurements were plotted and can be seen as a shaded band in Figure 75. The lower boundary of the band appears to correlate well with the predicted levels, but use of these minima would be purely arbitrary and without scientific foundation. Similar tests run with the second of the Kulites produced similar results. The ringing is believed to be caused by mechanical resonances in the transducer mount. Subsequent calibration of



(a) Free Space Overpressure Measurement

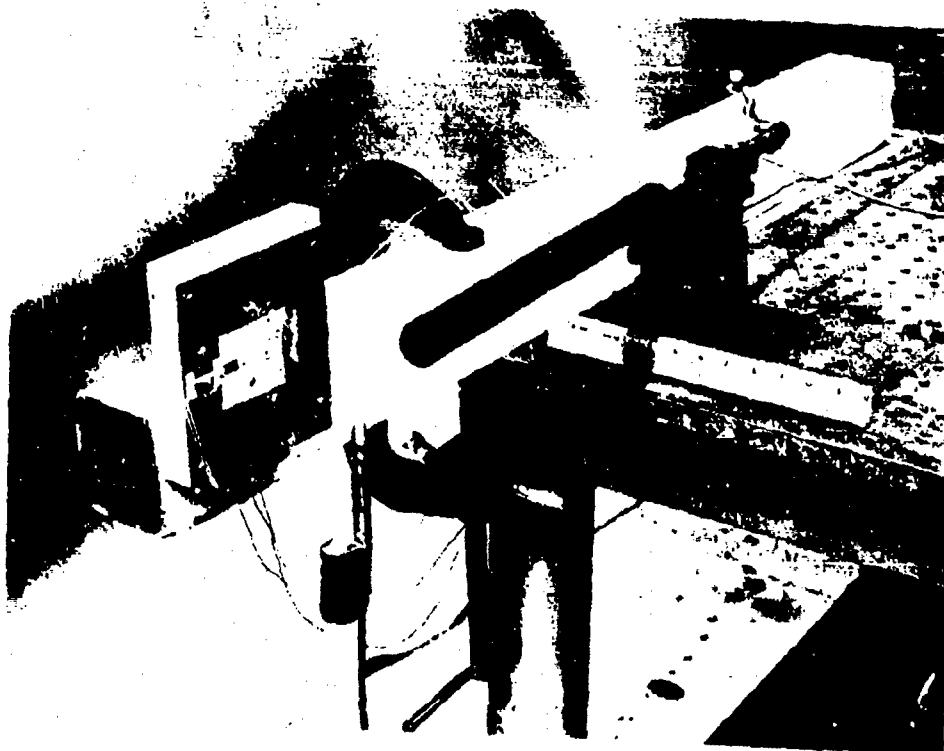

(b) Effects on Model Skin Panel

Figure 73. Test Setup for Measurement of Muzzle Blast

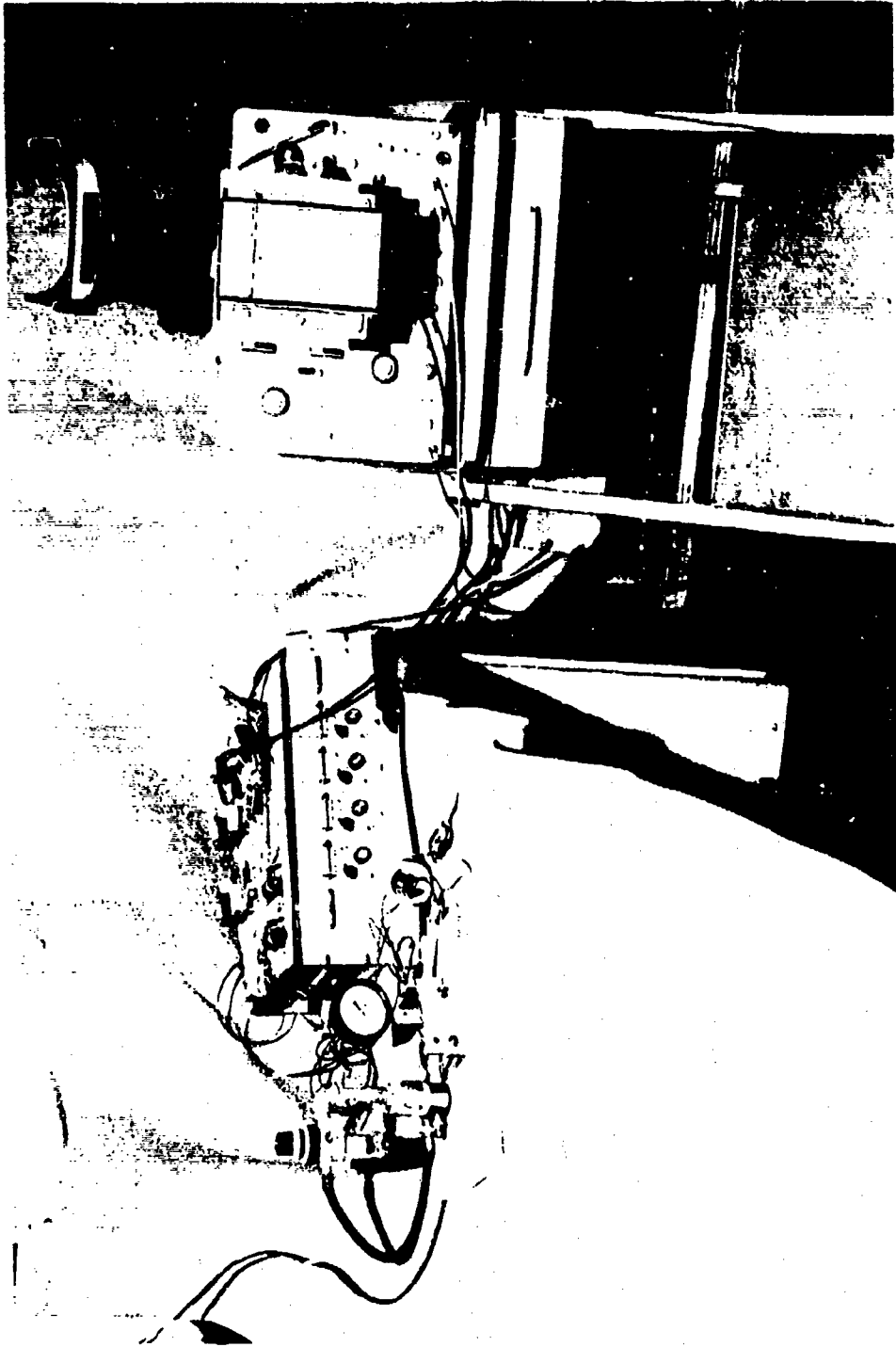

Figure 74. Test Setup for Transducer Calibration

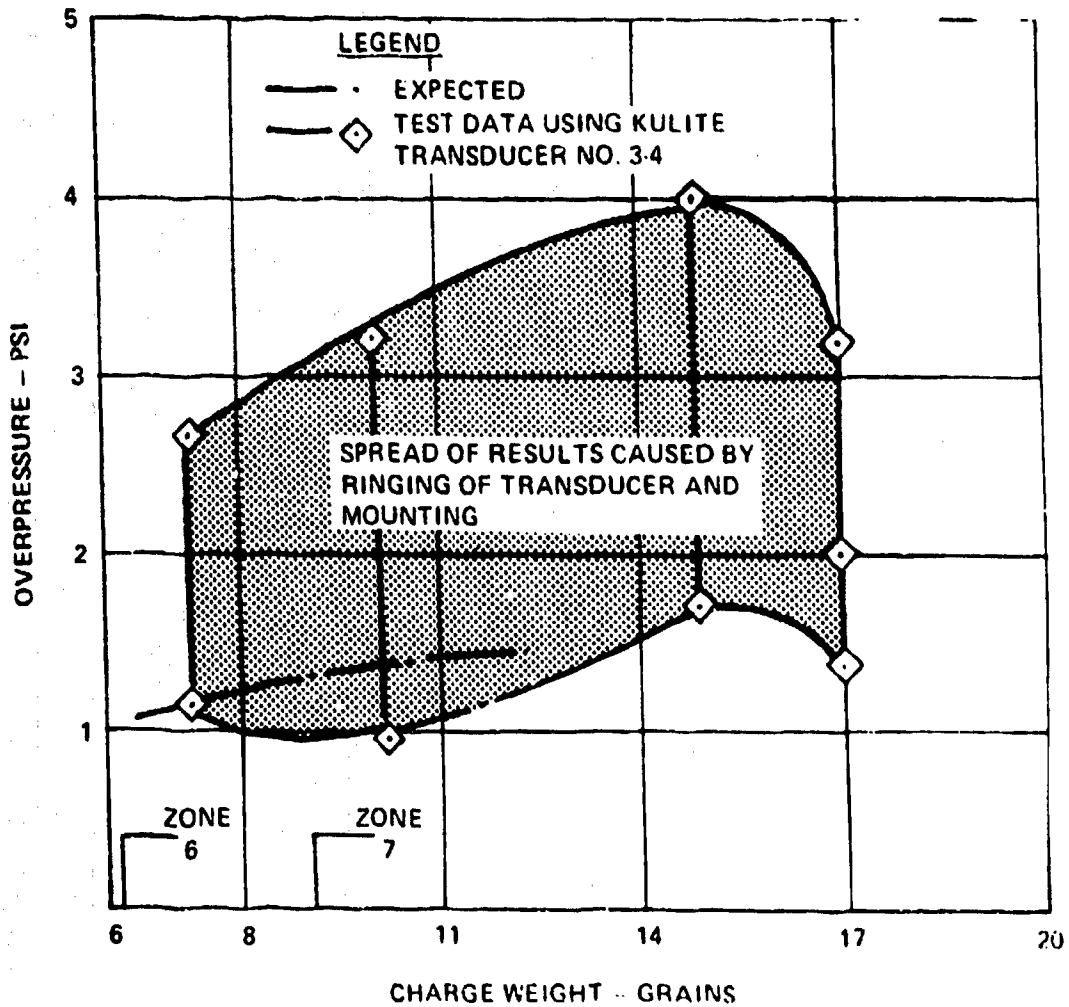

Figure 75. Comparison of Predicted and Model Overpressure Measurements at 40 Calibers Off Boresight Using Projectiles With Reduced Engraving

the Kulites in a fixture which restrains the mount produced a clean oscilloscope trace without hash. While the pressure-sensitive crystals in the SWRI transducers were solidly potted in their mounts, Boeing had refrained from this approach, fearing that the epoxy-curing heat might damage the Kulite pressure crystals.

Testing was performed with SWRI transducers 14-9 and 25-2, located at x/c's of 30 and 20 calibers, respectively. Figure 76 is a plot of overpressures measured at 30 calibers for various propellant weights. Good repeatability is in evidence; and correlation, which proved almost as good as at 40 calibers, was within .4 of a psi at zone 7 and even closer agreement at zone 6. When projectiles with reduced engraving were fired and measured at this same location, not only did the low charge zones successfully exit the barrel, but correlation was much improved. Figure 77 shows the results of these measurements.

Measurements taken with transducer 25-2 located at 20 calibers are shown plotted in Figure 78. Again, repeatability was excellent. Correlation with predictions was still good; however, when projectiles with reduced engraving were used (Figure 79), overpressures fell below predictions rather than above as in previous runs. Correlation was still within .5 psi.

Tests run at 10 calibers using SWRI pancake transducer 14-9 are shown in Figure 80. Results appear to run true to form, that is, progressively worsened correlation as measurement distances are decreased while repeatability is still good.

A summary curve, Figure 62, was then plotted showing comparison of predicted and interpolated test data for transducer locations of 10, 20, 30, and 40 calibers off boresight for 2.82 (zone 7) pounds of equivalent full-scale charge. Similarly, summary curves, Figures 81 and 82, were plotted for 3.23 and 3.8 pounds of equivalent full-scale charge, respectively. In all cases, the correlation between predicted and measured proved to be quite good.

PULSE DURATION

No data is presently available for time duration of the muzzle blast produced by the XM204 to enable comparison with measurements made during model testing. However, measurements made at Dahlgren (Reference 25) with a standard 105mm howitzer indicate that an average duration of 1.88 milliseconds was measured at approximately 20 calibers off boresight and in the plane of the muzzle. In addition, an average duration of 2.39 milliseconds was measured at approximately 40 calibers off boresight.

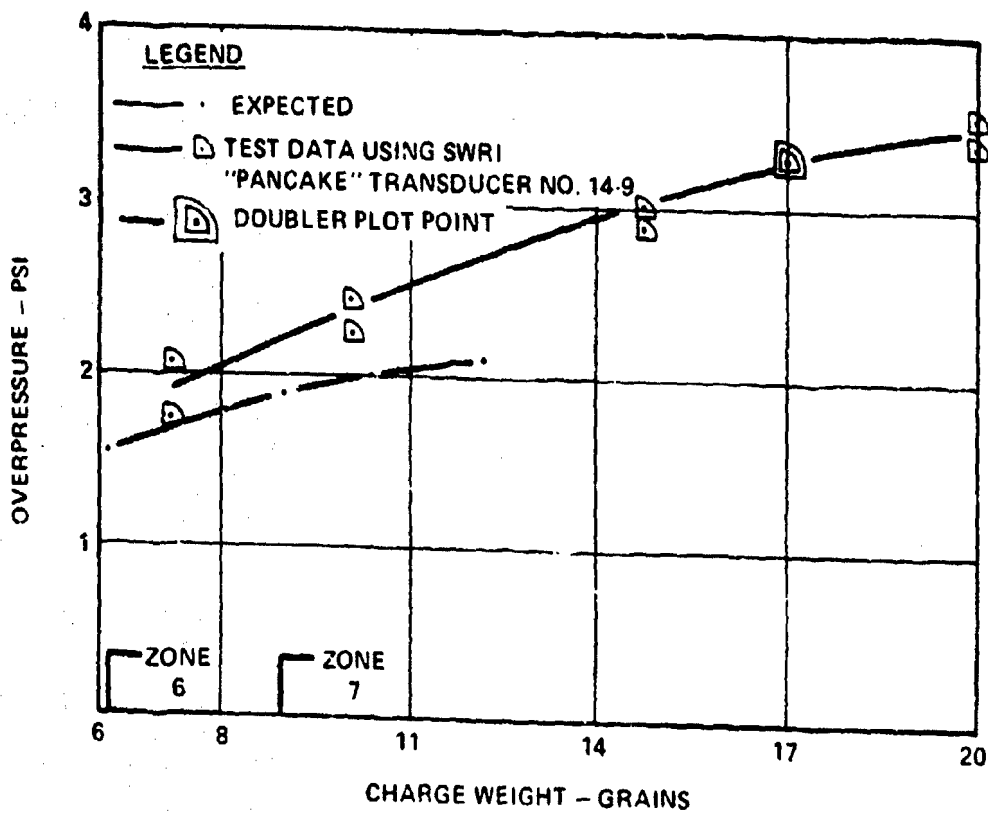

Figure 76. Comparison of Predicted and Model Overpressure Measurements at 30 Calibers Off Boresight

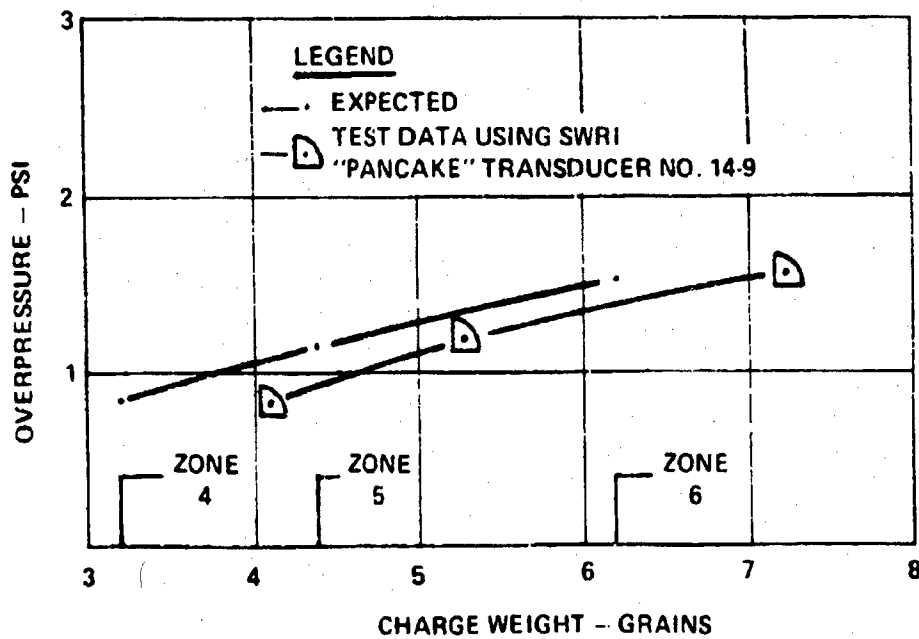

Figure 77. Comparison of Predicted and Model Overpressure Measurements at 30 Calibers Off Boresight Using Projectiles With Reduced Engraving

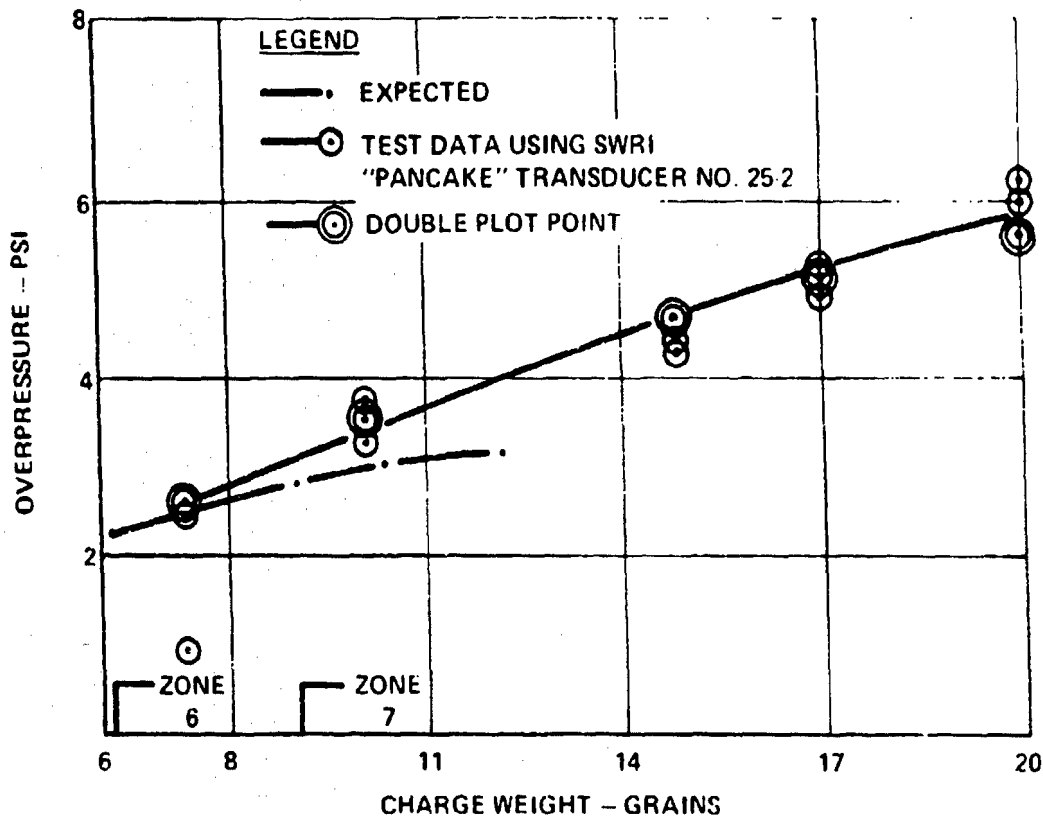

Figure 78. Comparison of Predicted and Model Overpressure Measurements at 20 Calibers Off Boresight

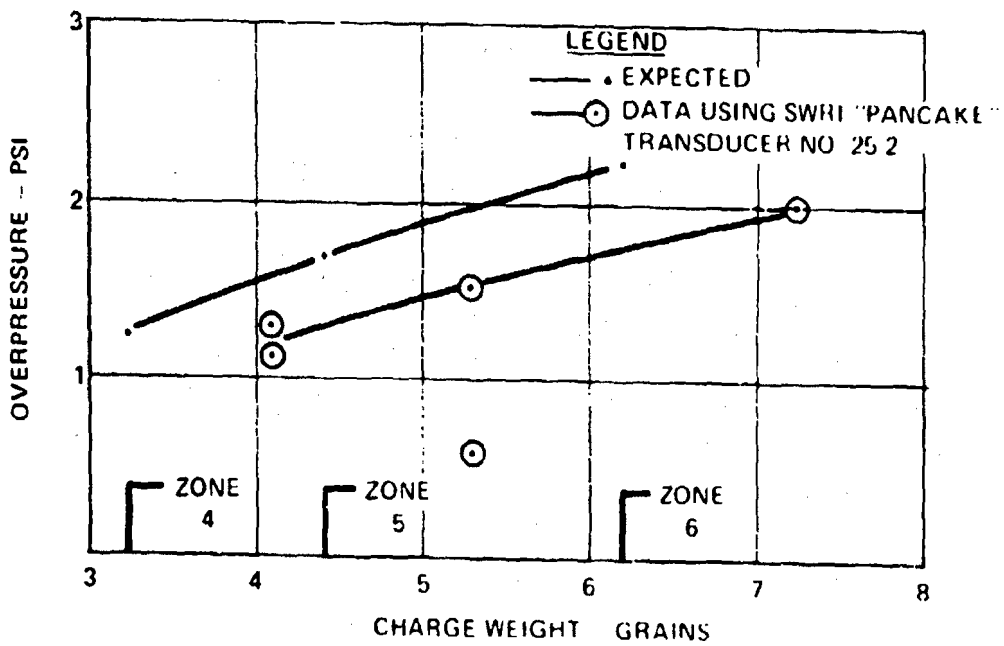

Figure 79. Comparison of Predicted and Model Overpressure Measurements at 20 Calibers Off Boresight Using Projectiles With Reduced Engraving

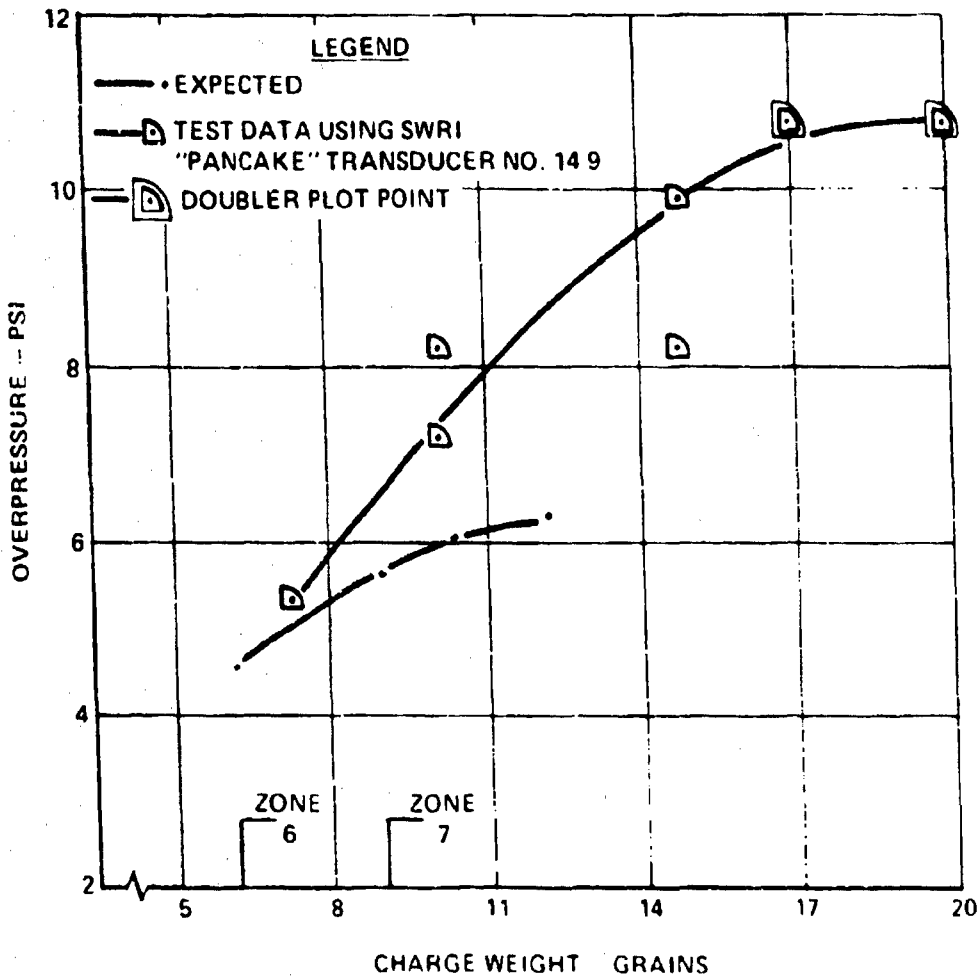

Figure 80. Comparison of Predicted and Model Overpressure Measurements at 10 Calibers Off Poresight

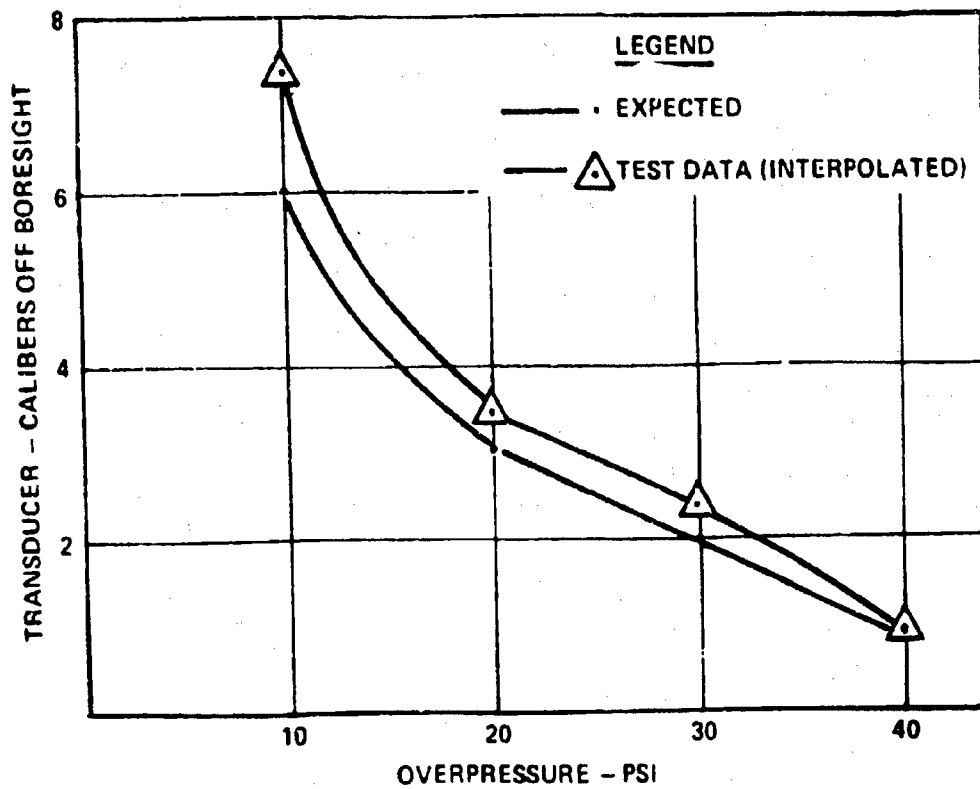

Figure 81. Comparison of Predicted and Model Overpressure Measurements for 3.23 Pounds Equivalent Full-Scale Charge

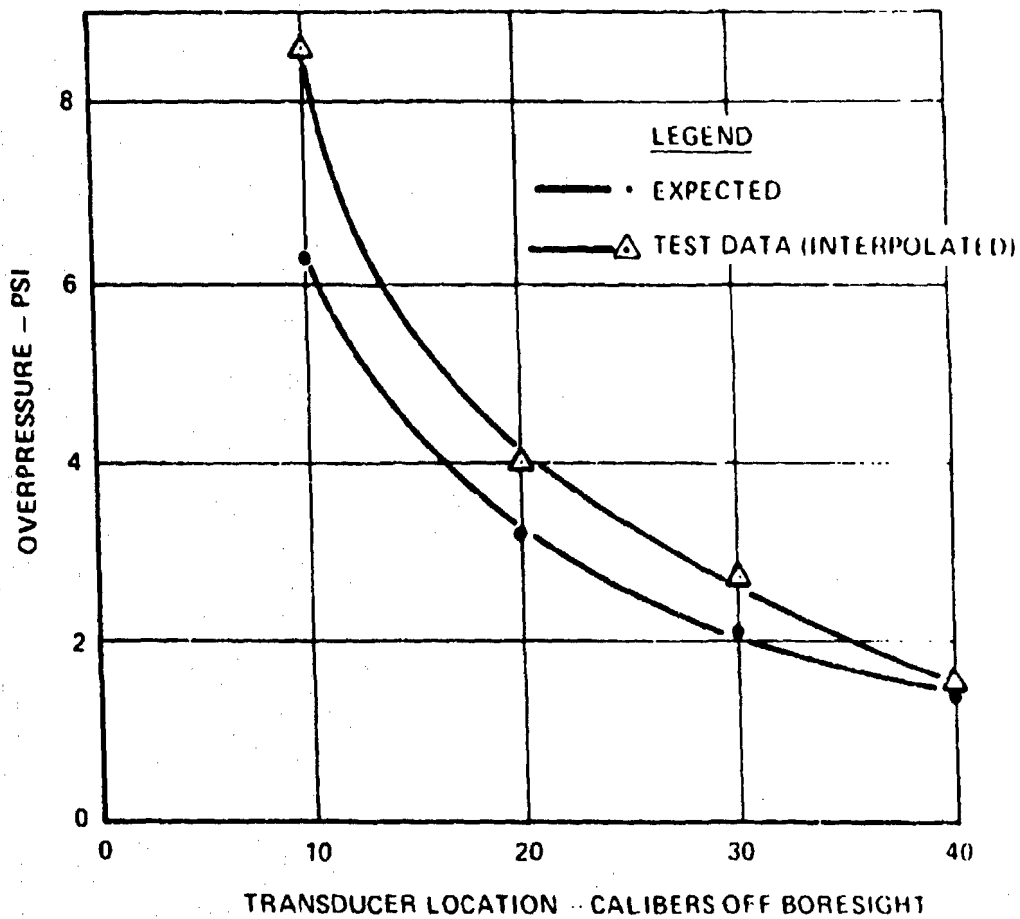

Figure 82. Comparison of Predicted and Model Overpressure Measurement for 3.8 Pounds of Equivalent Full-Scale Charge

Time duration was, in many cases, difficult to estimate from the scope traces of the model tests. However, an average of the 24 measurements made at 20 calibers yielded a time duration of 165 microseconds which, when scaled up by the factor of 11, equaled 1.82 milliseconds (only .06 milliseconds less than the full-scale Dahlgren data). The distribution appeared Gaussian, and the range varied from -.94 milliseconds to +.82 milliseconds from the arithmetic mean.

A plot of 15 measurements made at 40 calibers (the results of the ambiguous Kulite readings were not used) yielded a distribution curve which was somewhat skewed at the upper end. The average value of blast duration was 197 microseconds which scaled up to 2.17 milliseconds (as compared to 2.39 milliseconds for full-scale data). The distribution ranged from -.97 milliseconds to +.69 milliseconds of the arithmetic mean.

CALCULATIONS OF PREDICTED OVERPRESSURES

As an example of the method of predicting overpressures, calculations are presented for finding the predicted overpressure at $x/c = 40$ and $z/c = 14.4$ for a zone 7 charge fired from an XM204 howitzer with a 50-inch extended barrel. Calculations are based on Reference 6 with muzzle velocities obtained verbally from Rock Island Arsenal.

$$\text{Overpressure } (\Delta P) = \frac{KE_T}{C^2 L}$$

where

$$C = 4.16 \text{ in. (bore diameter)}$$

$$L = 12.5 \text{ ft (barrel length)}$$

$$E_T = \text{thermal energy (ft-lb)}$$

$$K = \text{dimensionless isobar constant}$$

Using Figure 4 of Reference 6, K is found to be 2.75×10^{-4} .

$$\Delta P = \frac{2.75 \times 10^{-4} (E_T)}{(4.16)^2 (12.5)}$$

$$\Delta P = 1.27 \times 10^{-4} (E_T)$$

where

$$E_T = E_A - \frac{E_P}{.85}$$

and

$$\begin{aligned} E_A &= \text{total energy available in propellant} \\ &= 1.4 \times 10^3 (H_C)(W_C) \end{aligned}$$

where

$$H_C = 700 \text{ cal/gram (for 105mm propellant)}$$

$$W_C = 2.82 \text{ lb (zone 7 charge)}$$

$$E_A = 1.4 \times 10^3 (700)(2.82)$$

$$E_A = 2.76 \times 10^6 \text{ ft-lb}$$

$$E_P \text{ (kinetic energy of projectile)} = \frac{M_P (V_O)^2}{2}$$

where

$$M_P = \text{projectile mass (slugs)}$$

$$V_O = 1700 \text{ ft/sec (zone 7 muzzle velocity)}$$

$$E_P = \frac{1.025(1.7 \times 10^3)^2}{2} \quad E_P = 1.48 \times 10^6 \text{ ft-lb}$$

so that

$$E_T = E_A - \frac{E_P}{.85}$$

$$E_T = 2.76 \times 10^6 - \frac{1.48 \times 10^6}{.85}$$

$$E_T = 1.02 \times 10^6 \text{ ft-lb}$$

and

$$\Delta P = (1.27 \times 10^{-6})(1.02 \times 10^6)$$

$$\Delta P = 1.3 \text{ psi}$$

CONCLUSIONS

Modeling of the XM204 howitzer to produce scaled muzzle blast

fields is feasible at 1/11 scale. Some further experimentation with propellant weight and projectile engraving would be in order as these parameters represent the greatest source of error. To a lesser degree, instrumentation and test setup is felt to be another error source. In model scale, the size and relatively blunt shape of the transducers raise concern. An isobar plot of XM204 overpressures shows that large pressure gradients exist at the close-in ranges, so a slight error would cause a fair percentage change in overpressure measurement. The knife edge of the transducer, while keen enough to slice into the pressure wave without perturbation at full-scale dimensions, is rather blunt at model dimensions.

It is felt that the SWRI gauges are satisfactory for model blast testing. The noise reported by Dahlgren was not experienced, and this is attributed to the use of shorter leads of Microdot cabling. Cable runs between transducers and charge amplifiers were limited to 10 feet. More suitable mounting provisions and retesting would be required before the Kulite transducers could be considered usable.

APPENDIX VII

TESTING OF MODEL STRUCTURAL PANEL WITH MODEL HOWITZER TO EXPLORE DYNAMIC EFFECTS OF MUZZLE BLAST

An instrumented model of a structural panel was fabricated and tested for response to muzzle blast to explore how well peak panel dynamic stresses due to blast can be predicted. The muzzle blast field was caused by a model howitzer. The model was an 1/11-scale structural representation of the most critical panel of the CH-47C for muzzle blast effects. The location of the scaled test panel relative to the muzzle of the model weapon is shown in Figure 83. It was found that if the panel is considered simply supported rather than clamped, and if the stress concentration at the edge of the panel is properly accounted for, the experimental findings can be adequately predicted.

The model panel was made of a readily-available aluminum sheetstock which was close to the desired model panel thickness. Number 3003 aluminum alloy with H27 temper and a yield strength (F_{ty}) and ultimate strength (F_{tu}) of 27,000 psi and 29,000 psi, respectively, was selected. Chemical milling was employed to reduce the .005-inch thickness of the sheetstock to the scaled value of .0036 inch. A .45-inch x 1.75-inch window (representing full-scale panel dimensions of 5 inches x 19.25 inches) was cut in a relatively thick aluminum plate to simulate the structure supporting the aircraft skin. The model skin was then cemented in place across the window and a strain gauge cemented to the skin. This assembly can be seen in Figures 84a and 84b. A Pitran pressure transducer was mounted on the supporting plate near the model skin to record reflected pressures.

To assure that the chemical milling did not reduce the strength of the model skin material, samples of milled and unmilled material were tested with a Siemens Microhardness Tester and found to have equal hardness. The assembly was then mounted on a wooden beam and positioned to simulate the aircraft with the panel approximately five calibers forward of the muzzle and 12 calibers parallel to the line of fire of the model weapon. Figure 73 shows this test setup.

The test was designed to demonstrate the firing of a zone 5 modeled charge (simulating the air-to-ground mode) without damaging the model panel. The model rounds used 7.25 grains of propellant. As mentioned in the model weapon discussions, it was found that the energy content of the model propellant was such that this model charge actually modeled a full-scale charge of 2.26 pounds which falls between zones 6 and 7.

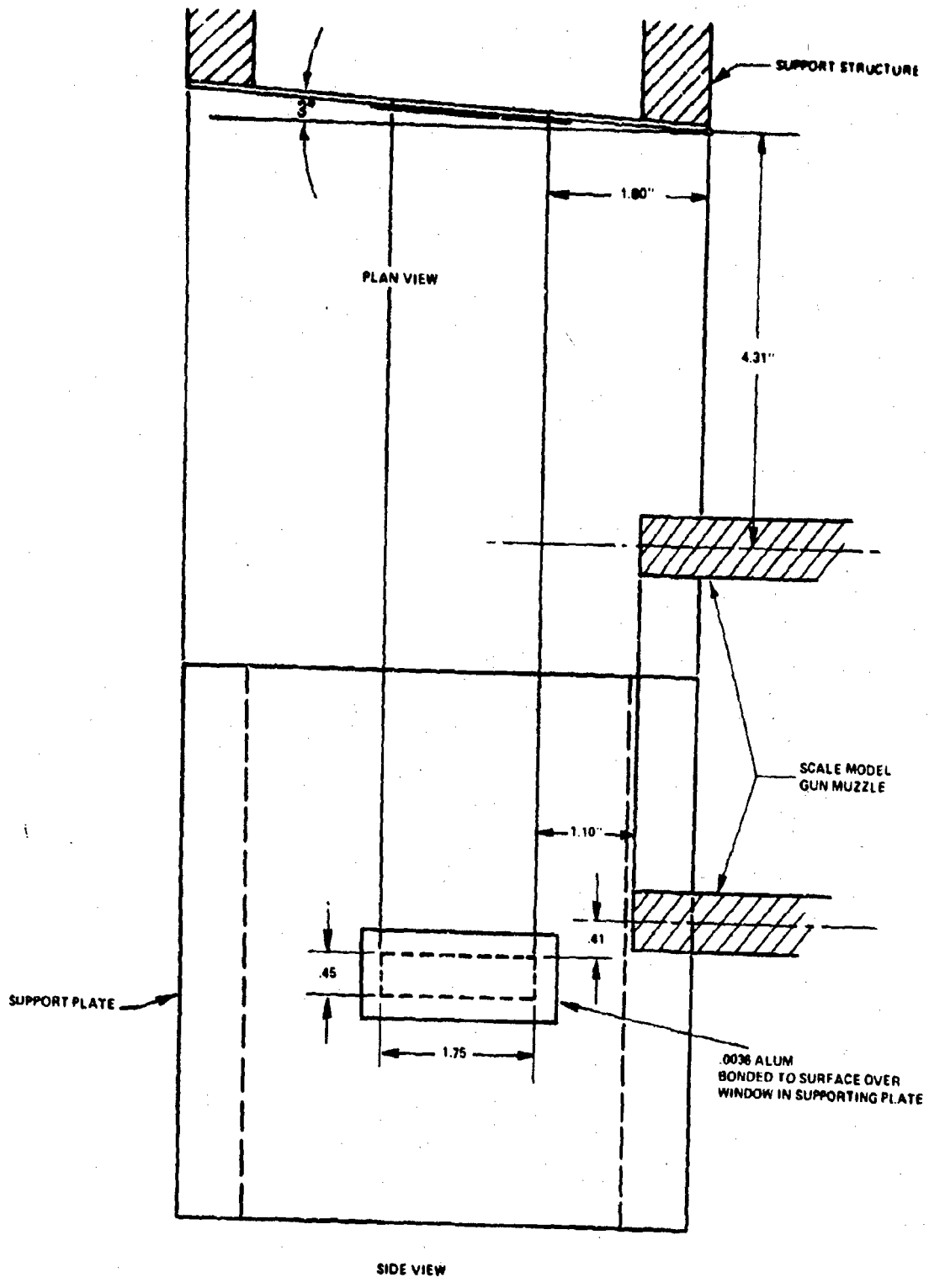
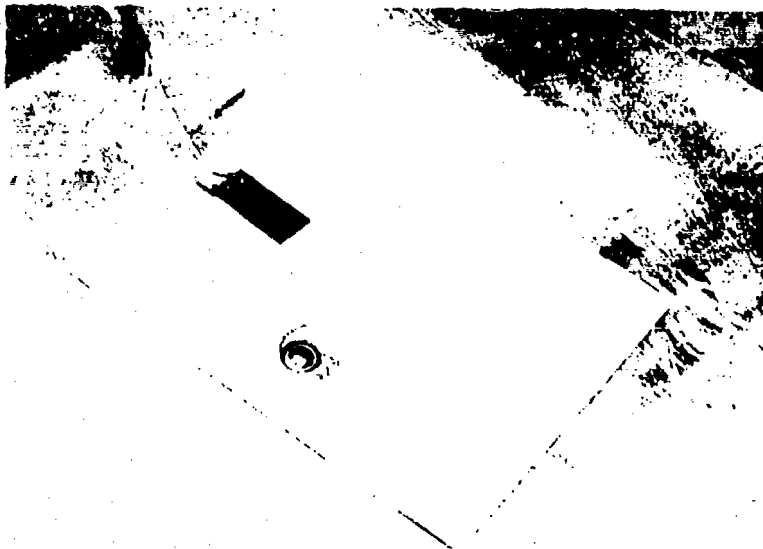

Figure 83. Scale Model Skin Panel and Supporting Structure



(a) Top View Showing Strain Gauge and Pitran Pressure Transducer Mounted



(b) Bottom View Showing Window in Panel Support Plate

Figure 84. Scale Model Skin Panel

Employing the formulae in the Salsbury report for general blast field solution, Reference 6, and using the full-scale muzzle velocity determined by use of the curve shown in Figure 65, a free-space blast overpressure of 5.5 psi was predicted for the geometry of this test setup. At this level of overpressure, the blast wave, which strikes the panel at a nearly-normal angle of incidence, experiences a reflection factor of 2.3, resulting in a reflected overpressure of 12.7 psi.

Using similar analysis to that shown for calculating protective panel doubler thickness, but using the lower yield strength of the model panel material, the dynamic yield strength of the model material is found by the formula:

$$\frac{\sigma_{y_2}}{\sigma_{y_1}} = \frac{F_{ty_2}}{F_{ty_1}}$$

$$\sigma_{y_2} = 143,600 \times \frac{27,000}{39,000}$$

$$\sigma_{y_2} = 99,300 \text{ psi}$$

where

σ_{y_1} = dynamic yield strength of full-scale panel material

σ_{y_2} = dynamic yield strength of model panel material

F_{ty_1} = static yield strength of full-scale panel material

F_{ty_2} = static yield strength of model panel material

The critical impulse for yield becomes:

$$I_c = \frac{\sigma Y}{C}$$

$$I_c = \frac{.0003 \times 9.93 \times 10^4}{16,470}$$

$$I_c = 1.81 \text{ psi-milliseconds}$$

where

δ = panel thickness (ft)

C = velocity of sound in aluminum (fps)

If the panel is considered to be clamped, its natural frequency is equal to:

$$f_0 = .985 \sqrt{\frac{E}{b^3}}$$

$$f_0 = \frac{.985 \times 21.76 \times 10^4 \times .0036}{(.45)^2}$$
$$= 3800 \text{ cps}$$

where

s = panel thickness (in.)

b = width (in.)

.985 = factor for aluminum

K = 21.76×10^4 for clamped panels

Its period

$$T = \frac{1}{3800} = 263 \times 10^{-6} \text{ seconds}$$

The critical time

$$t_c = \frac{263 \times 10^{-6}}{4} = 66 \times 10^{-6} \text{ seconds}$$

The maximum overpressure

$$\Delta p = I_c / t_c$$

$$\Delta p = \frac{1.81 \text{ psi} \cdot \text{ms}}{.066 \text{ ms}}$$

$$\Delta p = 27.4 \text{ psi}$$

It was therefore predicted that the model panel could withstand the reflected pressure of 12.7 psi with a safe margin. However, firing of the weapon actually resulted in panel yield. A close inspection of Figure 73 will show a faint outline of the hidden window in the support plate, resulting from panel yield. Some failure of the cement was also detected.

It was then theorized that the error lie in considering the panel to be clamped. If it were simply supported, the natural frequency would be:

$$f_0 = .985 K \frac{1}{b^2}$$

where

$$K = 9.6 \times 10^4 \text{ for simply supported panels}$$

$$f_0 = \frac{.985 \times 9.6 \times 10^4 \times .0036}{(.45)^2}$$

$$f_0 = 1675 \text{ cps}$$

Its period

$$T = \frac{1}{1675} = .597 \text{ milliseconds}$$

The critical time

$$t_c = \frac{.597}{4} = .149 \text{ milliseconds}$$

$$\text{And the allowable } \Delta p \text{ overpressure} = \frac{1.81}{.149} = 12.1 \text{ psi}$$

Therefore, were this truly a simply supported panel, test results of yield would correlate with predictions. In actuality, the panel most likely falls somewhere between the simply supported and clamped configurations. However, it is believed that the added mass of the strain gauge reduced the natural frequency of the panel (and its resulting critical time, t_c) just enough that when added to the reduction attributed to the method of support, resulted in a reduction of allowable overpressure to below that produced by the weapon.

The measurement of pressure by the Pitran gauge proved disappointing as its readings of 3.2 psi were far below the predicted level of reflected pressure. The scope trace was indistinct and difficult to interpret, and it can only be assumed that either the gauge was faulty or the calibration of the system was in error.

Strain gauge measurements obtained appear to be believable with an indicated strain (in the area of the gauge) of .00243 in./in. This is not the strain required for yield which is calculated as:

$$\epsilon = \frac{\sigma_Y}{E}$$

$$= \frac{99,300}{10.5 \times 10^6}$$

$$\epsilon = .00945 \text{ in./in.}$$

The difference in these two values apparently results from the positioning of the gauge away from the edge of the panel. It is reasonable to assume that the actual strain at the edges of the panel, where the greatest stress concentration occurs, is easily four times that measured in the area of the gauge. It is therefore understandable that yield occurred under these conditions.

It is concluded that model testing is a valuable tool in predicting full-scale responses to muzzle blast. Care must be taken, however, in design of the instrumentation and in the determination of the edge conditions of the panel.

APPENDIX VIII

PERFORMANCE SUBSTANTIATION

HOVER DOWNLOAD ESTIMATE

An estimate of the incremental increase in hover download of the Aerial Artillery configuration over the standard CH-47C is presented below.

Download, in terms of total rotor thrust, is expressed as follows:

$$\frac{DL}{T} = \frac{C_{D_V} A_V \frac{\rho}{2} v^2}{2 A \rho v_{IND}^2} = \frac{C_{D_V} A_V}{4 A} \left(\frac{v}{v_{IND}} \right)^2 = \frac{C_{D_V} A_V}{8 \pi R^2} \left(\frac{v}{v_{IND}} \right)^2$$

where: DL = hover download, lbs

T = total rotor thrust, lbs

C_{D_V} = vertical drag coefficient of fuselage section

A_V = exposed vertical drag area, sq. ft.

ρ = mass density of air, slug/ft³

A = total rotor disc area ($2 \pi R^2$), ft²

R = rotor radius, ft.

v = actual downwash velocity, ft/sec

v_{IND} = induced velocity from momentum theory

($\sqrt{T/2A\rho}$), ft/sec

The download between two locations A and B along the fuselage is:

$$\left(\frac{DL}{T} \right)_A^B = \frac{\overline{C_{D_V}}}{8 \pi R^2} \left(A_V \right)_A^B \int_A^B \frac{v}{v_{IND}} dx$$

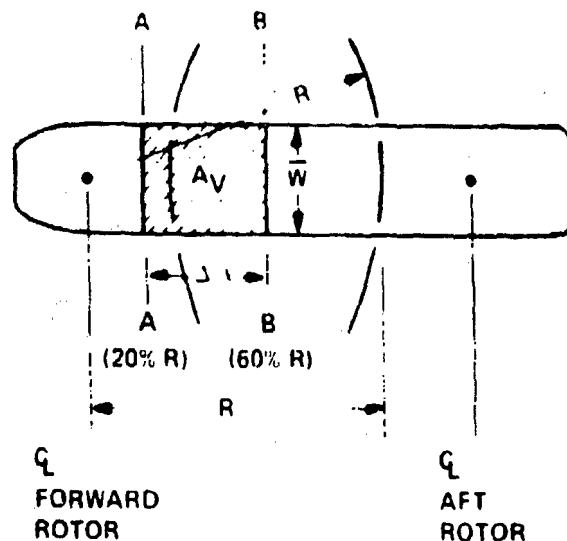

The exposed vertical drag area (A_v) between locations A and B in terms of average width (\bar{w}) and length (l) in percent of rotor radius ($\%R$) is noted below.

$$\left(\frac{A_v}{A}\right)_B^A = (l) (\bar{w}) = \left(\frac{60\%R}{100} - \frac{20\%R}{100}\right)_B^A (\bar{w}) = \frac{40\%R}{100} (\bar{w})$$

The final expression for hover download between locations A and B along the fuselage is

$$\begin{aligned} \left(\frac{DL}{T}\right)_A^B &= \frac{\bar{C}_{Dv}}{8\%R} \left(\frac{40\%R}{100}\right) (\bar{w}) \left(\frac{v}{v_{IND}}\right)_A^B \\ &= \frac{\bar{C}_{Dv}(\bar{w})}{800\%R} \left\{ \left[\left(\frac{v}{v_{IND}}\right)^2 (\%R) \right]_B - \left[\left(\frac{v}{v_{IND}}\right)^2 (\%R) \right]_A \right\} \end{aligned}$$

Figure 85 presents the downwash velocity profile developed from model rotor test data expressed in terms of integrated non-dimensional downwash velocity $\left[\int \left(\frac{v}{v_{IND}}\right)^2 (\%R) \right]$ as a

BASIS: UNIVERSAL HELICOPTER MODEL TEST DATA FOR TANDEM
ROTOR CONFIGURATION WITH 34% ROTOR OVERLAP

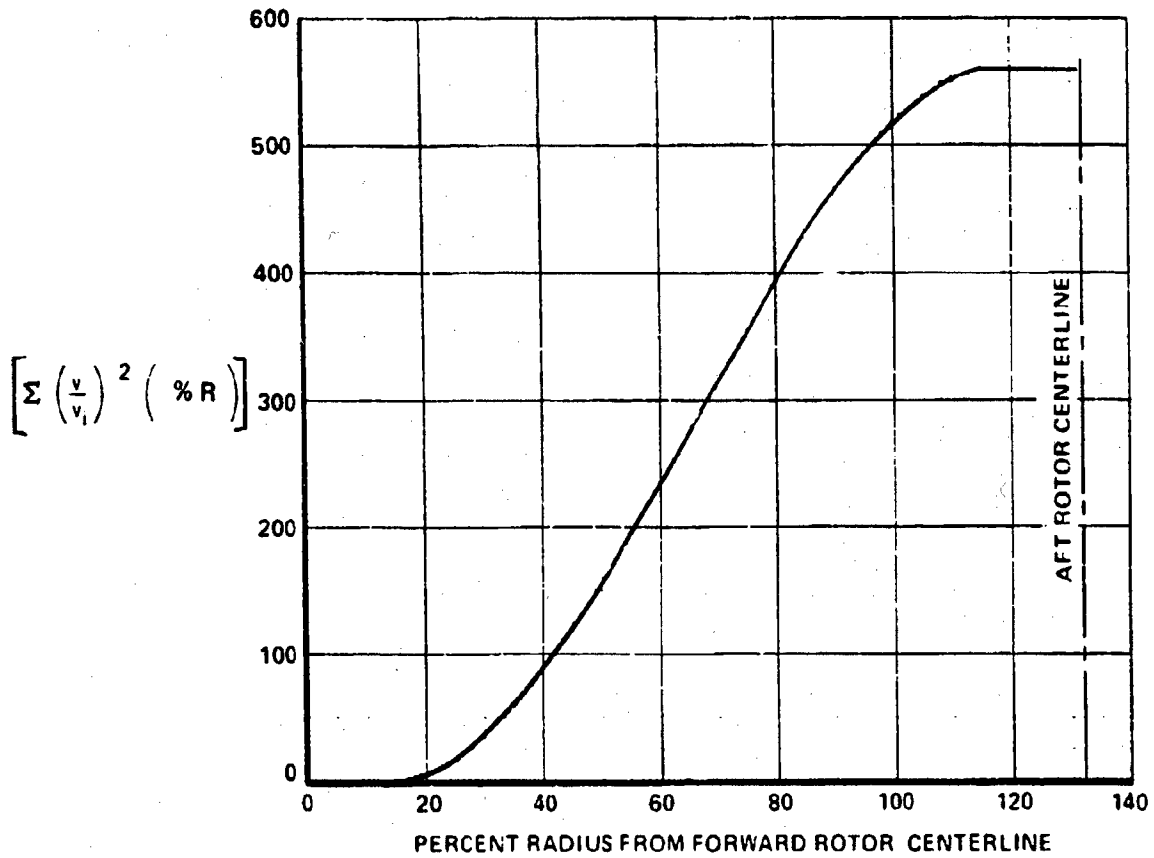

Figure 85. Downwash Velocity Distribution Used for Hover Download Calculation

function of percent radius from the forward rotor centerline. The test data was obtained with a tandem rotor model having the same rotor overlap as the CH-47C helicopter.

Applying this methodology to the CH-47C aerial artillery configuration the following incremental hover download estimate is made for the dual gun installation.

$$\left(\frac{DL}{T}\right)_A^B = \frac{\overline{C_{DV}}(\bar{w})}{(75,400)} \{K_B - K_A\}$$

WHERE, $K = \left[\frac{V}{V_{IND}} \right] (\%R)$

Permanent Howitzer

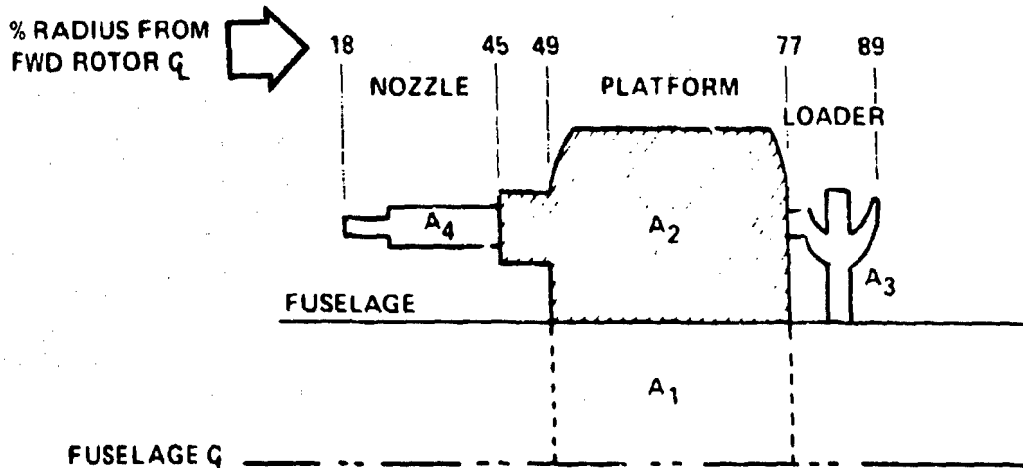

Ref. Area	Exposed Area			$\overline{C_{DV}}$	$\%R$	K	$\{K_B - K_A\}$	$\left(\frac{DL}{T}\right) (\%)$
	A_V (sq. in.)	W (in.)	\bar{w} (ft.)					
A1	5230	96	4.54	.43 (1) (2)	49	150	220	.57
A2	7842	114	5.72	1.00 (1)	77	370	250	1.90
					77	370		
A3	1254	47	2.22	1.20 (3)	77	370	85	.30
					89	455		
A4	1216	94	1.08	.80 (1)	18	0	120	.14
					45	120		
Total : $\left(\frac{DL}{T}\right)$ for permanent howitzer								2.90

NOTES:

- (1) Reference: "Technology Instruction Manual", W.B. Peck and C.B. Fay, Boeing-Vertol Division
- (2) $\Delta C_{Dv} = .43$ added to ref. area, A_1 to account for extended platform, A_2 , influence on vertical drag of adjacent fuselage
- (3) Reference: "Fluid Dynamic Drag", Sigward F. Hoerner, 1965

Removable Howitzer

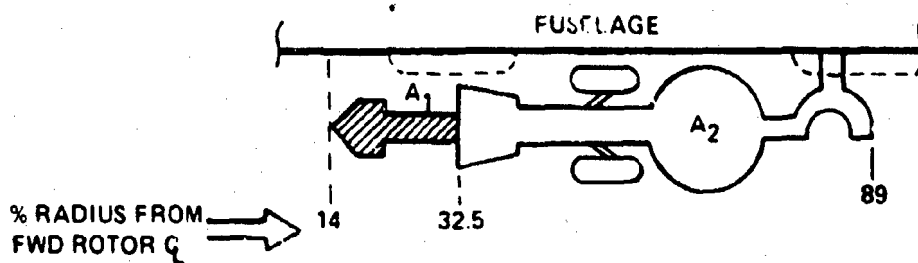

Ref. Area	A_v (sq. in.)	A_R (in.)	\bar{w} (ft.)	C_{Dv}	$\%R$	K	$\{K_B - K_A\}$	$(\frac{DL}{T})$ (%)
A_1	1170	65	1.5	.80	14.0 32.5	0 45	45	.07
A_2	8496	204	3.5	1.20	32.5 89.0	45 455	410	2.28
Total $\Delta (\frac{DL}{T})$ for Removable Howitzer								2.35

The net increase in hover download of the aerial artillery configuration over the standard configuration CH-47C is summarized below:

Hover Download (Percent of Total Rotor Thrust)	
2.90	Permanent Howitzer Installation
2.35	Removable Howitzer Installation
5.25	Net Increase Over CH-47C

EQUIVALENT DRAG AREA ESTIMATE

An estimate of the increase in equivalent drag area (f_e) of the aerial artillery aircraft over the standard CH-47C helicopter is presented below.

Permanent Howitzer

Component	Quantity	A_F	C_D	Interference Factor	f_e
		Projected Frontal Area (ft ²)	Based On Projected Frontal Area		Equivalent Flat Plate Drag Area (ft ²)
Gun proper, Platform and Loader	1	14.58	.8 ⁽¹⁾	1.25	14.6
Main Support Beam	1	8.12	1.2 ⁽²⁾	----	9.7
Total f_e for Permanent Howitzer					24.3

Removable Howitzer

Component	Quantity	AF	CD	f_e
		Projected Frontal Area (ft ²)	Based On Projected Frontal Area	Equivalent Flat Plate Drag Area (ft ²)
Gun proper	1	20.10	.8(1)	16.1
Retracted Gun Wheel & Axle	1	1.90	.4(2)	.8
Main Support Beams (Fwd & Aft)	2	8.43	1.2(2)	20.2
Winch Support Beams (Fwd & Aft)	2	6.16	1.2(2)	14.8
Total Δf_e for Removable Howitzer				51.9

NOTES:

- (1) Reference: NACA Memo No. 1-31-59L, "Parasite Drag Measurements of Helicopter Rotor Hubs", G.E. Churchill & R.D. Harrington, Feb 1959
- (2) Reference "Fluid Dynamic Drag", Sigward F. Hoerner, 1965

The aerial artillery configuration has a net increase in equivalent flat plate drag area (Δf_e) of 76.2 square feet over the standard configuration CH-47C as summarized below:

Equivalent Drag Area (f_e) (FT ²)	
24.3	Permanent Howitzer Installation
51.9	Removable Howitzer Installation
76.2	Net Increase Over CH-47C